

Off-road Rubber Track Dumper

SC75

Operator's Manual

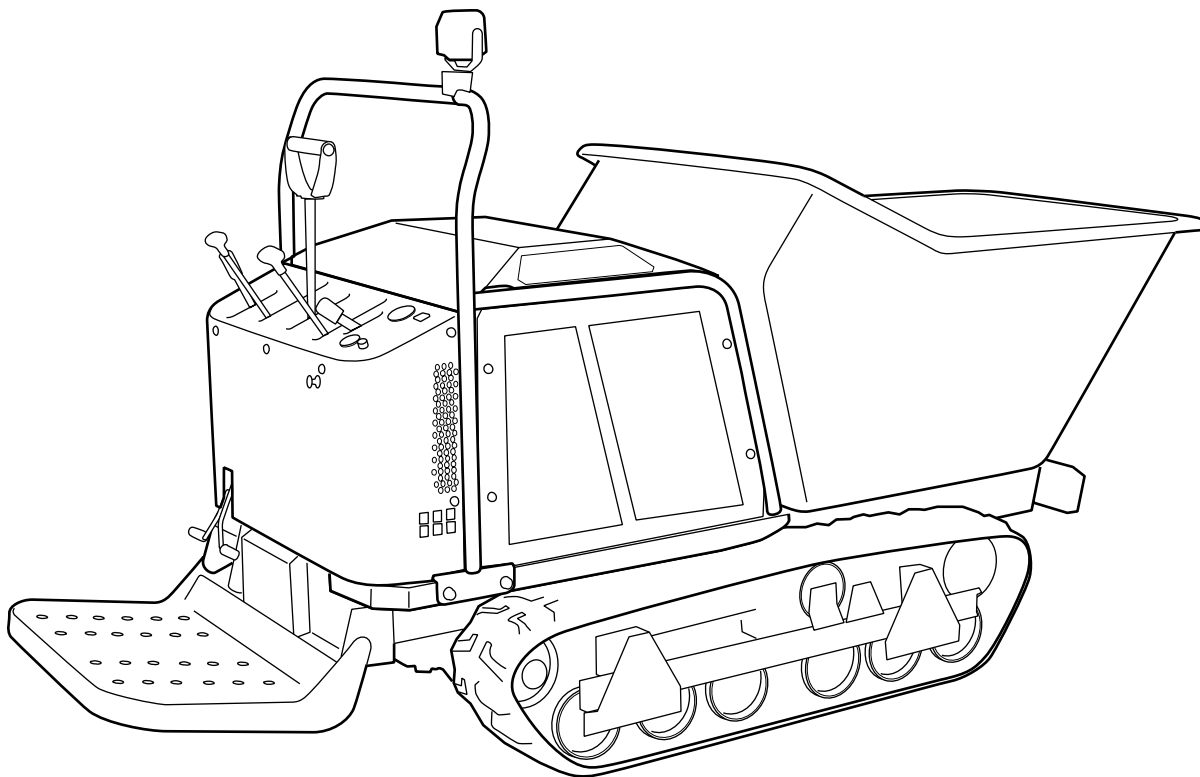

⚠ WARNING!

Read this manual completely before operating or maintaining this machine. Failure to follow safety precautions could result in serious injury or death. Keep this manual for future reference by you and by all those who operate and maintain this machine.

3570 5105 000

Original Instructions (in English)

CHIKUSUI CANYCOM, INC.

<http://www.canycom.co.jp/>

CHIKUSUI CANYCOM, INC.
90-1 Fukumasu, Yoshii-machi,
Ukiha-shi, Fukuoka, Japan 839-1396

Sales Headquarters (International) TEL +81-(0)943-75-2195
FAX +81-(0)943-75-4396

Authorized Dealer

Notice to Users and Maintenance Personnel

Thank you for purchasing this machine.

This manual provides information needed for safe and effective use of this machine to those who operate or maintain the machine. Make sure to read and understand the manual thoroughly before operating the product. Also make sure to read the separate operator's manual for the engine.

⚠ WARNING!

- **This machine can be very dangerous if the safety precautions in this manual and on the labels attached to this machine are not followed. Read and understand this manual and the safety labels on the machine thoroughly before using this machine. Always follow the instructions and safety precautions, or serious injury or death could result.**
- **This machine should only be used for its intended purpose: hauling and dumping. Any other use could be dangerous.**
- **This machine may not be operated on public road or what is considered to be public road. It is sole responsibility of the operator to consult the local regulations.**
- **Do not modify this machine, or do not operate this machine with the safety covers removed or open. A serious accident could result.**

⚠ CAUTION!

- **Store this manual in a safe, accessible place for easy reference.**
-



Notice to Owner

CAUTION!

- Be sure that everyone who uses this machine, including those who rent or lease this machine, receives a copy of this Operator's Manual and understands the importance of reading and following the information in this manual.

Warning Terms Used in this Manual

In this manual, the following four warning terms are used to signal the four levels of hazard (or seriousness of possible accidents). Read and understand what they mean and always follow the instructions in this manual.

Warning Term	Definition
 DANGER!	Indicates an imminently hazardous situation which will result in death or serious injury if the user does not follow the procedures or the instructions.
 WARNING!	Indicates a potentially hazardous situation which could result in death or serious injury if the user does not follow the procedures or the instructions.
 CAUTION!	Indicates a potentially hazardous situation which could result in minor to moderate injury or damage to the machine if the user does not follow the procedures or the instructions.
<u>NOTE</u>	Indicates important information which needs particular attention.

Warranty and After-Sales Service

Warranty

CHIKUSUI CANYCOM, INC. provides you a warranty through CANYCOM U.S.A. A copy of this warranty is reproduced in the back of the manual.

After-Sales Service

Consult your local CANYCOM dealer or our company's sales department regarding service orders or any questions or problems that may arise when using this machine. Please make sure to have the product name, serial number, and the make and type of the engine handy at the time of contact. The model and serial number can be found on the model label as shown below, and the make and type of the engine can be found in Chapter3 "Specifications" of this manual (Page12).

Location of Model Label

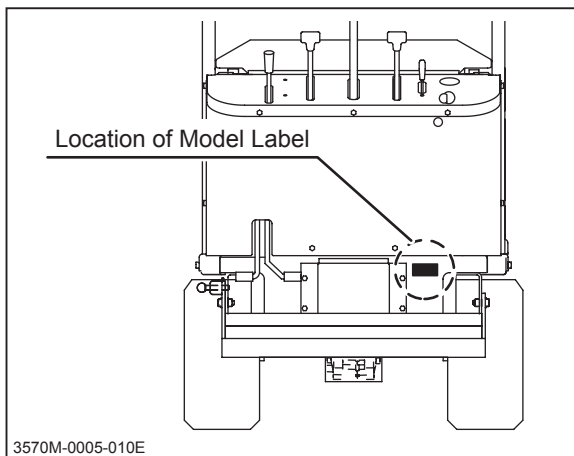

Model Label



Availability of Spare Parts

The replacement or repair parts for this product shall remain available for seven years after the production of this type of machine is discontinued.

Contents

1. Safety 1

Safety Labels 1

Safety Precautions 3

 Training 3

 Preparation 4

 Operation 4

 Servicing 9

2. Controls and Components 10

Name and Function of Controls 10

3. Specifications 12

Product Specifications 12

Contents of the Tool Bag 13

4. Operation 14

Preparation 14

 Pre-start up Inspection 14

 Checking and Filling Fuel 14

Driving 16

 Starting 16

 Driving 19

 Stopping 22

 Parking 22

Working	24
Dumping and Turning	24
Using Safety Prop.	27
Folding/Unfolding Step	28

5. Maintenance **29**

Maintenance Schedule	29
List of Fluids and Lubricants	34
Greasing and Lubricating Points	34
List of Consumables and Spares	35
Removing and Installing Body Panels	36
Engine Compartment	36
Engine	38
Engine Oil	38
Oil Filter	40
Air Cleaner.	40
Spark Plugs.	41
Drive Train.	42
Tracks	42
HST (HydroStatic Transmission) Fluid	43
Line Filter and Suction Filter	44
Transmission Oil.	45
Drive Belts	47
Belt Stoppers.	48
Parking Brake	48
Control Stick	50
Greasing and Lubricating	52

Hydraulic System	54
Hydraulics Belt	54
Electrical System	55
Battery	55
Fuses	57
After Use Care	58
After Normal Use	58
After Cold Weather Use	58
Storage	60

6. Troubleshooting **61**

Troubleshooting	61
-----------------------	----

7. Transporting **65**

Hauling	65
Loading and Unloading	66
Hoisting	67

Warranty

Warranty Certificate is attached at the end of this manual.

- * Have the warranty certificate signed and sealed after you have received and fully understood the instructions for handling this machine and received the receipt.

Appendix

- Operator's Manual for the Engine
 - * Be sure to read and understand it together with this manual .
-

Safety Labels

The safety labels shown on the next page are attached to the machine. See the illustration below for the location and the illustration on the next page for the content of each label on the machine.

- **Locate all the warning labels attached to this machine. Read and follow the instructions and precautions in them. Failure to do so could result in serious injury or death to the operator or bystanders.**
- **Keep the labels clean and legible. Do not use solvents or gasoline to clean the labels.**
- **Replace these labels immediately if they have been removed, have fallen off or become illegible. Use the part number, on the label or shown in this manual, to order a replacement label from your CANYCOM representative.**

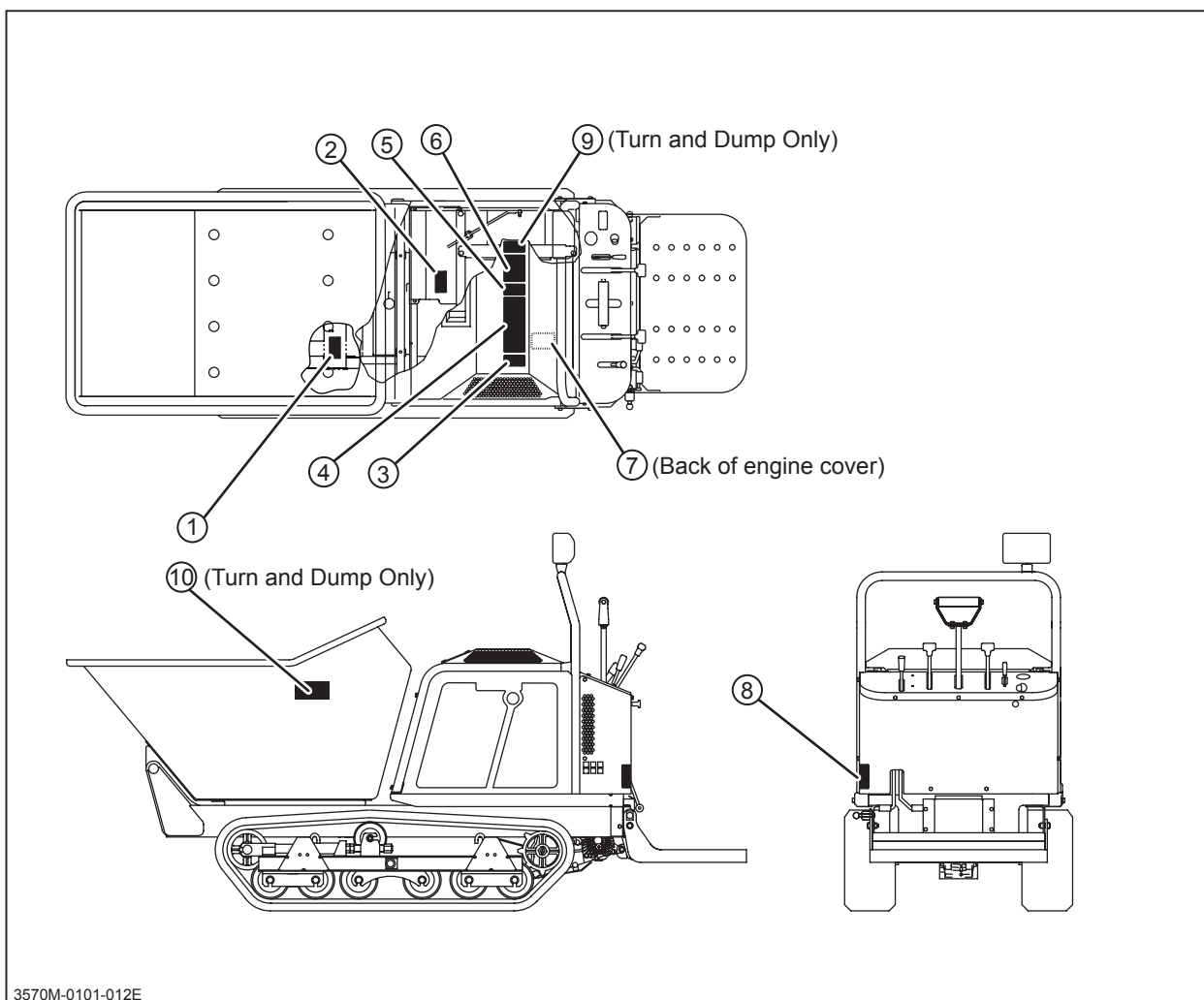

① 3667 5066 000



② 3667 5062 000



③ 3667 5063 000



④ 3667 5061 000

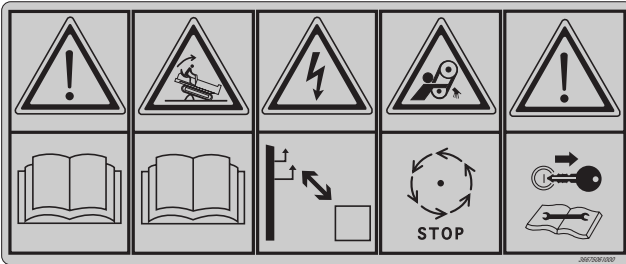

⑤ 3667 5064 000



⑥ 3570 5438 000



⑦ 3667 5068 000



⑧ 3570 5421 000



⑨ 3677 5007 300



⑩ 3670 5114 000

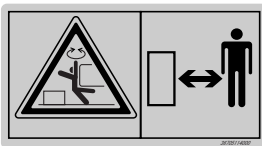

3570M-0101-022E

Safety Precautions

This section contains safety precautions to follow when operating and maintaining the machine. Read and understand the precautions in this section as well as throughout this manual and follow them when operating or maintaining the machine. Failure to follow safety precautions could result in property damage, serious injury or death to the operator or bystanders.

Training

All operators and mechanics should receive practical instructions from their employer or renter. Such instructions should cover the following issues:

- **It is essential to familiarize yourself with the controls, safety labels and the proper use of the machine.**
- **Never allow people unfamiliar with these instructions to operate or service the machine. Local regulations may restrict the minimum age of the operator. Consult your local authority.**
- **The operator is responsible for the accidents or hazards caused to other people or their property.**
- **This machine has a riding capacity for one person only. Do not carry passengers other than the operator.**
- **Always keep in mind that care and concentration is required when working with ride-on machines.**
- **Loss of control on a slope cannot be regained by the application of the brake. The main reasons for loss of control are:**
 - **insufficient grip of tracks.**
 - **excessive speed.**
 - **misjudging of the ground conditions, especially slopes.**
 - **incorrect distribution of load.**

Preparation

⚠ WARNING!

- Fuel is highly flammable. See Checking and Filling Fuel, page 14, for important safety information on handling fuel.
- Always wear protective footwear, long trousers, hardhat, safety glasses and ear protection when operating or servicing the machine. Proper clothing will minimize the chance of injury. Do not operate the equipment if you have long hair, loose clothing, or jewelry; all of which may get tangled in moving parts. Do not operate the machine barefoot or with open sandals.
- Prepare beforehand the working rules and procedures such as signaling and traffic control for the work place. Following such rules will reduce the risk of accidents.
- Never handle fuel or grease, service the engine, or recharge the battery in the presence of fire or spark.
- Perform the daily pre-startup inspection (see Maintenance Schedule, page 29) before starting the machine. Repair or replace damaged parts before starting the machine.

Operation

This machine is intended for carrying liquid concrete, sand and dirt. Carrying other materials may damage the machine. Avoid carrying hot materials. That will damage the machine.

The stability of the machine is affected by the speed, rate of steering, terrain and the load. Always pay close attention to these factors or a loss of control or tip over could occur, resulting in property damage, serious injury or death.

General Driving

- Do not operate the engine in a confined space where dangerous carbon monoxide fumes can accumulate.
- Do not touch the engine, muffler or exhaust pipe while the engine is running or soon after it has stopped. These areas will be very hot and can cause burns.

- Do not operate the machine under the influence of alcohol or drugs.
- Always check for obstacles before operating on new terrain.
- Before starting the engine and moving the machine, be sure all persons are a safe distance away from the machine. Sound the horn to warn bystanders.
- Always hold the guide rail with one hand to keep your posture when the machine is moving.
- On a slippery surface, travel slowly and exercise caution to reduce the chance of skidding or sliding out of control. Never operate on ice.
- Always make certain that there is no obstacle or a person behind the machine when backing up. After confirming that it is safe to back up, move slowly and avoid sharp turns.
- To reduce the risk of tip over, pay special attention when encountering an obstacle or a slope, or when braking on a slope or during a turn. See Driving on a Slope on the next page.
- Never attempt to drive over a large obstacle such as rock or fallen tree.
- Always travel slowly and use extra caution when operating on unfamiliar terrain. Be alert when traveling on changing terrain.
- Never operate on terrain that you are not comfortable with. Avoid terrain that is so rough, slippery or loose that you feel like you could tip over.
- Do not operate the machine near the edge of a cliff, an overhang or a slide area.
- Do not make sudden maneuvers. A sudden start, stop, or turn can make the machine lose control and could cause a tip over. Be especially cautious when traveling on soft or wet ground.

- Drive at a safe speed, taking into account the surface gradient, surface conditions and load.
- Use an observer to help direct the machine when the visibility is poor, terrain is rugged or hilly, or maneuvering room is limited. The observer should be able to see the machine and its immediate surroundings, and should give pre-arranged signals to direct the operator.

Driving on a Slope

WARNING!

- Never use on a slope steeper than 20 degrees.
 - Driving on a slope can be dangerous. It can result in a tip over and cause serious injury or death. Take the following precautions.
- Always follow proper procedures for driving on a slope as described in this manual.
 - Driving on a slope in a wrong manner can cause a loss of control or a vehicle tip over. Check the terrain carefully before attempting to drive on a slope.
 - Never drive on a slope that you are not comfortable with. Avoid a slope that is so rough, slippery, or loose that you feel like you could tip over.
 - When driving up a slope, proceed at a steady rate of speed and throttle position.
 - Never move the throttle lever or the control stick suddenly.
 - Drive straight up or down a slope. Avoid turning on a slope.
 - If the engine stalls or loses traction during a climb and cannot make it to the top of the slope, do not try to turn the machine around. Carefully back down slowly, straight down the slope.
 - When going over the top of a slope, go slow; an obstacle, a sharp drop, or another vehicle or person could be on the other side of the crest.

- **Avoid driving the machine across a slope.**
- **Without a load, drive the machine backwards up a slope (operator's step uphill) when climbing, and drive it forward when going down a slope.**
- **With a load, drive the machine forward up a slope (operator's step downhill) when climbing, and drive it backwards when going down a slope. Be especially cautious when operating on a slope with a load.**
- **When driving down a slope, use the control stick so that the machine travels down at the minimum speed. Use the engine speed to help keep the machine speed low.**

Loading and Driving with a Load

- **The maximum payload for this machine is 750 kg. Do not exceed this maximum payload under any circumstance.**
- **Do not operate on a slope steeper than 20 degrees when carrying a load. Do not carry more than 375 kg when operating on a slope between 15 and 20 degrees. Keep in mind that liquid concrete will shift in the bucket and hence its center of gravity also shifts, affecting the stability of the machine.**
- **Load cargo in the bucket so the weight is evenly distributed. Keep in mind that liquid concrete will shift in the bucket and hence its center of gravity also shifts.**
- **When carrying a load, drive at a reduced speed. Allow a greater distance for braking.**
- **Before crossing a bridge or an overpass, make certain that the total combined weight of the machine, the load and the driver is within the stated weight limit for the bridge or the overpass. Then, proceed carefully and at a constant speed.**

Dumping / Turning

When turning the bucket and dumping material from the bucket, take the following precautions.

- **Always follow the proper procedures for dumping or turning as described in this manual.**
- **Only operate the bucket with the engine running.**

- Perform the dump operation on a flat, level and stable surface whenever possible. Raising or lowering the bucket on a slope or rough terrain could result in a tip over.
- Pay special care when dumping with the bucket turned to a side. Be tentative when raising the bucket which is turned to a side.
- Make certain that all persons are at a safe distance away from the machine when raising, lowering, or turning the bucket.
- Do not move the machine or leave it unattended with the bucket in the raised position.
- Engage the bucket safety prop if you must place any part of your body under the bucket in the raised position.

Parking

- Park the machine on a flat, level and stable surface. Never park on a slope steeper than 15 degrees. Avoid parking on a slope less than 15 degrees. If parking on a slope less than 15 degrees is unavoidable, turn the bucket straight, apply the parking brake and block the tracks at the lower end of the machine.
 - Without a load, park the machine with the operator's step toward the uphill
 - With a load, park the machine with the operator's step toward the downhill
 - Do not park sideways on a slope.
- Observe all the previous precautions for driving, driving on a slope, loading and driving with a load, dumping, and turning.
- Whenever you park the machine, apply the parking brake and stop the engine. Remove the key whenever you leave the machine unattended to prevent unauthorized use or accidental starting.
- Gasoline is extremely flammable and can be explosive. When parking the machine indoors, make certain that the building is well ventilated and that the machine is not close to any source of flame or spark, including appliances with pilot lights.

Servicing

- **Do not service the machine when the engine is running. If it is absolutely necessary to run the engine while servicing, pay attention to the moving parts.**
- **Make certain that there is adequate ventilation when operating the engine indoors to prevent poisoning by exhaust gas.**
- **Make sure all hydraulic line connectors are tight and all hydraulic hoses and lines are in good condition and leak-free before applying hydraulic pressure to the system.**
- **Keep your body and hands away from pinhole leaks or nozzles that eject hydraulic fluid under high pressure. Use paper or cardboard, not your hands, to search for leaks. Hydraulic fluid escaping under pressure can have sufficient force to penetrate the skin and cause serious injury.**
- **Check all fuel lines on a regular basis for tightness and wear. Tighten or repair them as needed.**
- **If the engine must be running to perform a service, keep hands, feet, clothing and any part of the body away from any moving part, especially the cooling fan and the belts at the side of the engine.**
- **Do not touch the engine, muffler, or exhaust pipe while the engine is running or soon after it has stopped. These areas will be very hot and can cause burns.**
- **The engine must be shut off before checking or adding oil.**

2

Controls and Components

Name and Function of Controls

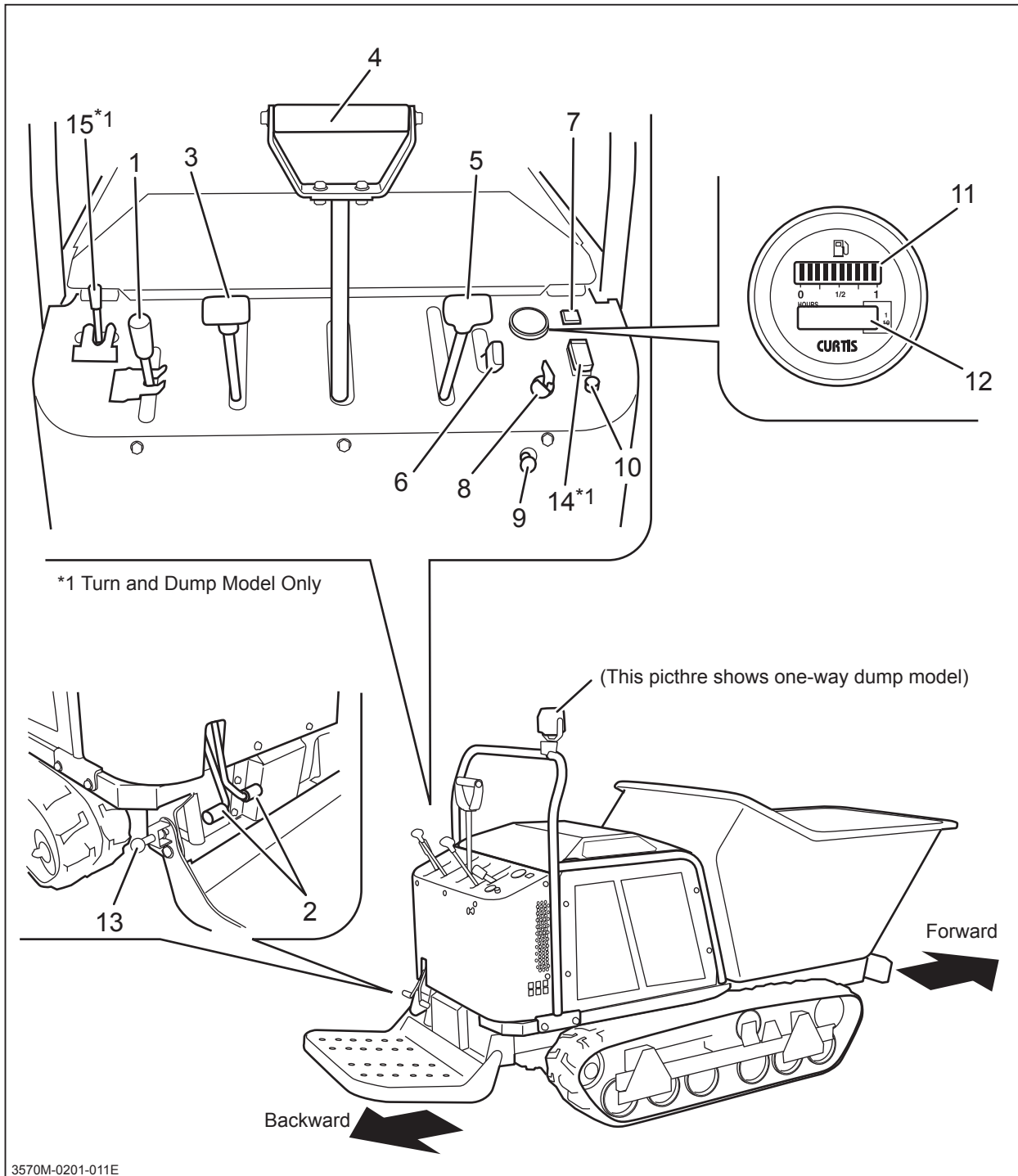

- 1 Dump Lever** Raises or lowers the bucket.
- 2 Dump Pedals** Coupled to the dump lever and raises or lowers the bucket.

-
- 3 **Clutch Lever** Disengages the clutch to help start the engine in the cold.

 - 4 **Control Stick**. Control stick is used to control the traveling direction (forward or backward, as well as left or right) and speed of the machine.

 - 5 **Parking Brake Lever** Parking brake lever is used to park the machine securely.

 - 6 **Throttle Lever**. Throttle lever is used to control the engine speed.

 - 7 **Engine Oil Warning Lamp** . Lights up when the Main Switch is turned to the [| (run)] position. If there is no problem, it goes off when the engine is started. If a problem is detected when the engine is running, it lights up.

 - 8 **Main Switch** Main switch is used to start or stop the engine.

 - 9 **Choke Knob** Pulling the choke knob closes the choke valve to help start the engine in the cold weather. Push the knob back to open the valve once the engine starts.

 - 10 **Horn Button** Pressing this button sounds the horn. Use this for warning during traveling or signaling during operation.

 - 11 **Fuel Gauge** Displays the amount of fuel in the tank.

 - 12 **Hour Meter** Hour meter displays and records the total amount of time the machine has been in use, in the unit of 0.1 hour.

 - 13 **Step Lock knob**. Step lock knob is used when folding / unfolding the step.

 - 14 **Lamp Switch** Pressing lamp switch to light up the head lamp.

 - 15 **Turn Lever** This is used when turning the bucket.

Product Specifications

⚠ CAUTION!

· Use this product properly after understanding its specifications thoroughly.

Model and Type			SC75		
			One-Way Dump	Turn and Dump	
Machine Mass		kg	640	680	
Maximum Payload		kN	7.35		
Dimensions	Overall Length		mm	2695	2730
	Overall Width		mm	900	
	Overall Height		mm	1470	1345
	Track Contact Length		mm	965	
	Track Gauge		mm	700	
	Ground Clearance		mm	115	
	Loading Deck Height		mm	450	575
Loading Deck	Inner Dimensions	Length	mm	1295	1325
		Width	mm	765	785
		Height	mm	540	545
	Volume	Struck	m ³	0.41	
Engine	Model		Robin EH65DS		
	Type		Air-cooled 4-cycle V-twin Gasoline		
	Cylinder (Bore×Stroke)		mm	80×65	
	Displacement		cm ³	653	
	Maximum Output		kw(PS)	16.4(22.0)	
	Maximum Torque		N•m(kgf•m)	45.6(4.65)	
	Starter System		Electric		
	Fuel		Automotive Unleaded Gasoline		
	Fuel Consumption		g/kW•h(g/PS•h)	310 (230)	
	Fuel Tank Capacity		L	20	
	Oil Capacity		L	1.4 [1.55 ; including oil filter]	
	Ignition		Electronic Ignition		
	Spark Plugg		NGK BP6ES		
Electrical	Battery Type		40B19R		
	Battery Capacity		V/AH	12/28	
	Working Lamp		V/W	12/18.4	12/55

Model and Type			SC75		
			One-Way Dump	Turn and Dump	
Performance	Speed	km/h	0-4.0		
	Minimum Turning Radius	m	1.5		
	Gradability	Degrees	20 (Empty)		
HST Oil Capacity		L	23		
Drive Train	Main Transmission		Twin HST		
	Steering		Twin HST, 1 Lever		
	Brakes		Internally Expanding		
	Track Size		mm	200	
	Transmission Oil Capacity		L	2.0	
Dumping System	Dumping System		Front Dump		
	Hydraulic Pump	Type	Gear Pump		
		Max. Speed	rpm	2,300	
		Max. Discharge	L/min	17.6	
	Relief Pressure		MPa (psi)	9.8 (1421)	
	Cylinder(Bore X Stroke)		mm	60×400	
	Performance	Max. Angle	Degrees	90	
		Lifting Time	Sec	4.0	
		Lowering Time	Sec	3.4	
	Turning Angle		Degrees	-	90 Left and Right
Hydraulic Fluid Capacity		L	Shared with HST System		

*These specifications are subject to change without notice.

Contents of the Tool Bag

No.	Content	Quantity	Note
1	Operator's Manual	1	This Manual
2	Operator's Manual for the Engine	1	
3	Engine Service Tool	1	for Servicing the Engine

Preparation

Pre-start up Inspection

Always perform an inspection before use.

Refer to the **Maintenance Schedule** (page 29) for the inspection schedule and procedure.

Checking and Filling Fuel

⚠ WARNING!

- Keep fire and spark away when handling fuel.
- Always stop the engine before refueling.
- Do not fill beyond the limit (bottom of the filler filter) so that fuel will not overflow. In case fuel is spilt, wipe out immediately.

⚠ CAUTION!

- Pinch point; watch your hands when shutting the engine hood.

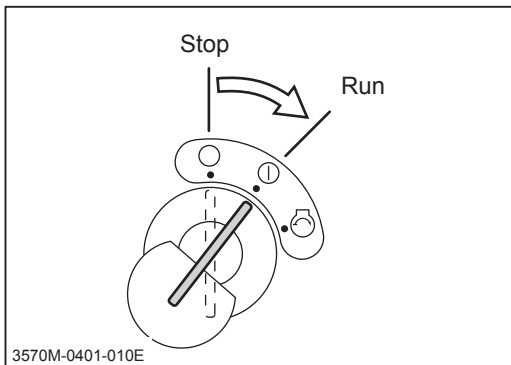

Checking Fuel

1. Insert key into main switch.
2. Turn main switch to [| (run)] position.

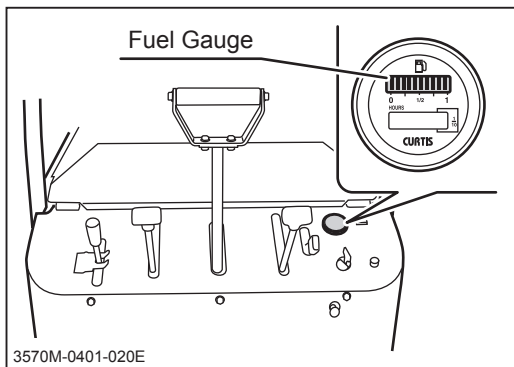

3. Check fuel gauge.

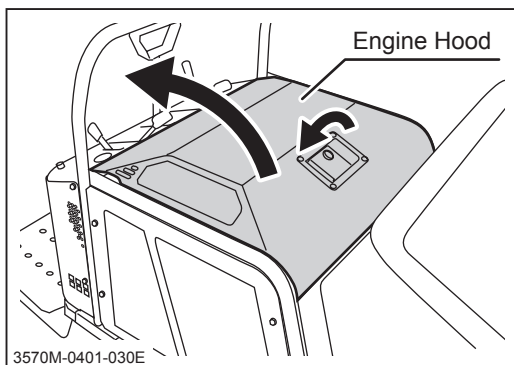

Filling Fuel

1. Pull handle to open engine hood. Hood stays open thanks to gas damper.

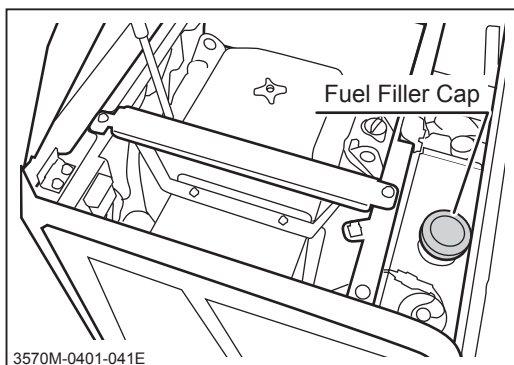

2. Open fuel filler cap and fill fuel. Put fuel filler cap back in place and tighten it securely. Push hood until it latches to close.

NOTE

- Fuel : Automotive Unleaded Gasoline
- Fuel Tank Capacity : 20L

Driving

Starting

⚠ WARNING!

- Always start and run the engine in a well ventilated place.
- Always make certain of the safety of your surroundings when starting the engine.

⚠ CAUTION!

- Do not turn the starter when the engine is running. The starter motor and/or the engine may be damaged.
- Do not turn the starter for more than 5 seconds. If the engine does not start, wait for 10 seconds or more before attempting to start again.
- In the winter or cold climate, warm up the engine thoroughly before driving the machine. Driving with the cold engine may cause excessive wear.

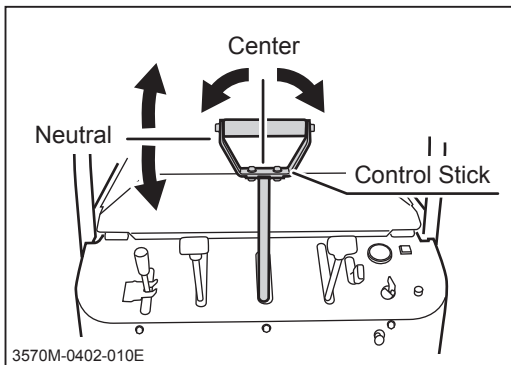

1. Make sure control stick is in the neutral position and on center (not twisted).

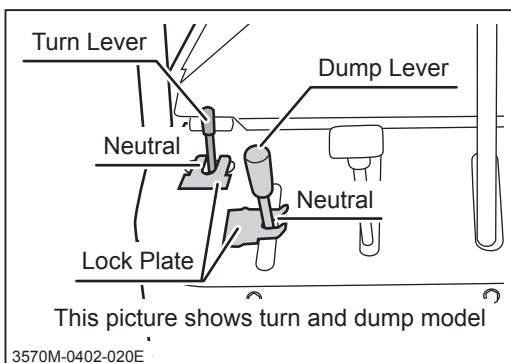

One-way Dump Model

2. Make sure dump lever is in the neutral position and lock plate is in the locked position.

Turn and Dump Model

2. Make sure dump lever and turn lever are in the neutral position and lock plates are in the locked position.

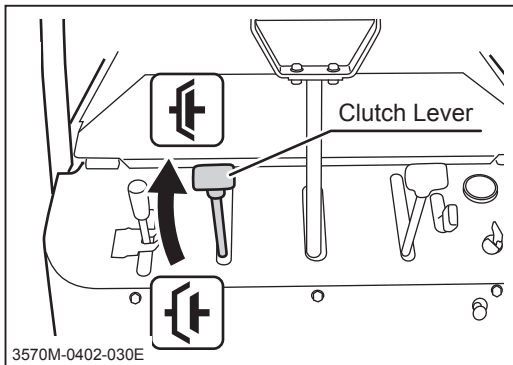

Normal Starting

3. Move clutch lever to [⚙️ (engaged)] position.

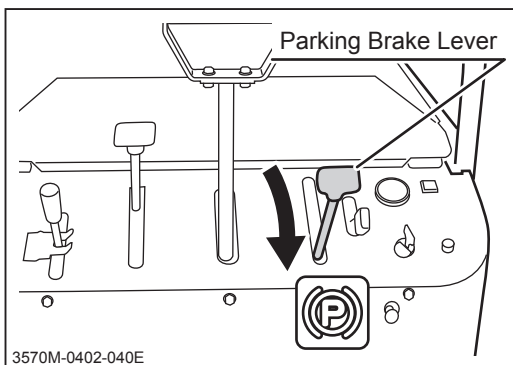

4. Move parking brake lever to [Ⓟ (engaged)] position.

NOTE

- Engine cannot be started unless control stick is in neutral and centered, and parking brake is in [Ⓟ (engaged)] position. This is due to the safety feature on this product.

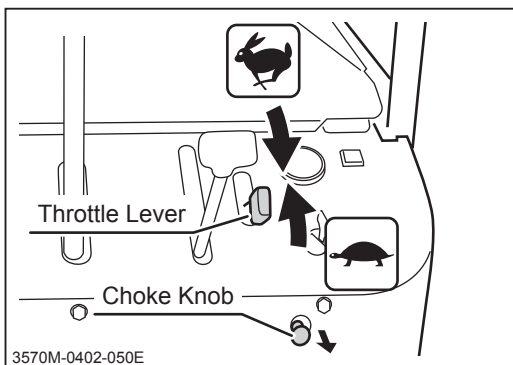

5. Set throttle lever in between [🐇 (fast)] and [🐢 (slow)] positions.
6. Pull choke knob.

NOTE

- When engine is warm, it is not necessary to pull the choke knob.

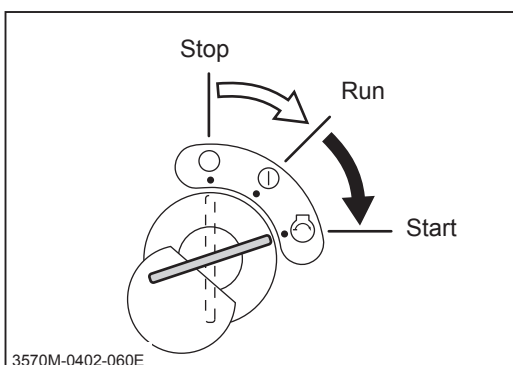

7. Insert the key into main switch.
8. Turn main switch to [🔑 (start)] position to start engine. Once engine starts, release key immediately; switch will automatically return to [| (run)] position.

9. Move throttle lever to [⬅️(slow)] position.
10. Push choke knob to the original position.
11. Allow engine to warm up by running it for 3-5 minutes without any load. (It is not necessary when the engine is already warm.)

NOTE

- Drive the machine gently in the first week or so, (40-50 hours) of use after purchase for breaking-in.

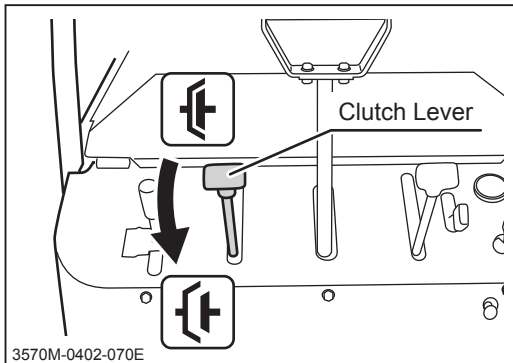

Starting in Cold Weather

3. Move clutch lever to [⬇️ (disengaged)] position.
4. Follow 4 to 10 in the normal starting procedure above.

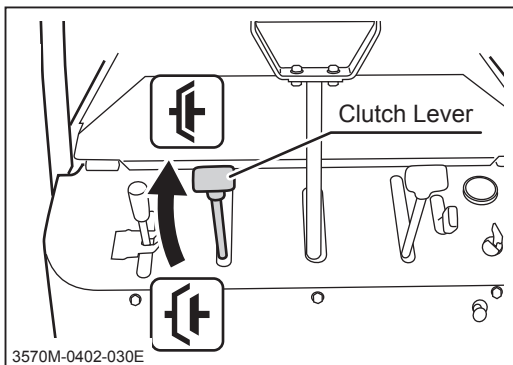

5. Move clutch lever to [⬆️ (engaged)] position.
6. Allow engine to warm up by running it for 3-5 minutes without any load.

Driving

⚠ WARNING!

- Do not allow bystanders to come near the machine when driving.
- Always make certain of the safety of your surroundings before driving; start slow.
- Always make certain of the safety of your surroundings before turning
- Do not make sudden start, acceralation, change of speed, change of direction, or stop. Do not turn at speed. Avoid sudden maneuvers; this may cause the operator to fall or the machine to tip over.
- Do not turn the key to [○ (off)] position while traveling. Machine can lose stability and tip over.
- Always move the control stick back to the neutral and centered position before releasing. Letting it go from other operationg positions may result in sudden deceleration and can cause the machine to tip or the operator to fall.

⚠ CAUTION!

- Do not operate the control stick when the parking brake is in [Ⓟ (engaged)] position. It can wear out the brake.

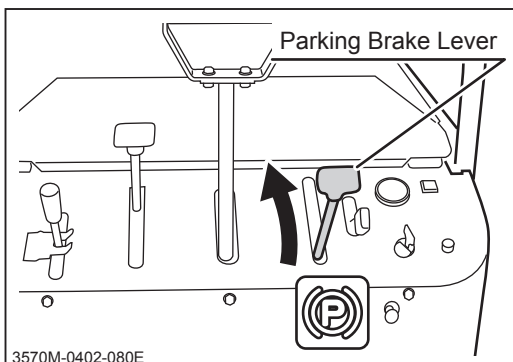

1. Make certain of the safety of your surroundings.
2. Move parking brake lever away from [Ⓟ (engaged)] position.

NOTE

- If control stick is operated while parking brake is in [Ⓟ (engaged)] position, warning buzzer beeps. Release parking brake before operating steering lever.

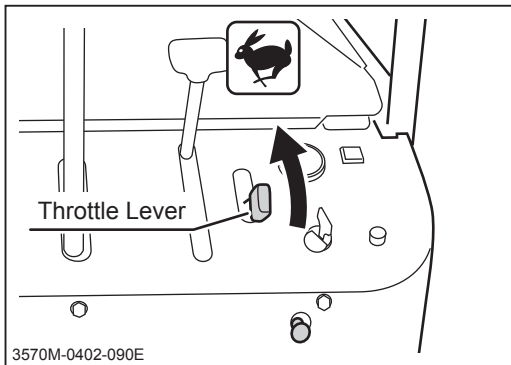

3. Move throttle lever toward [ (fast)] position to increase engine speed.

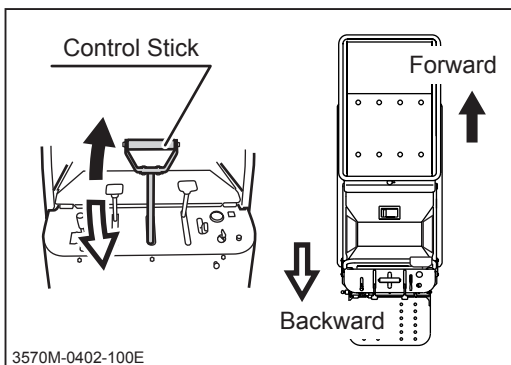

Moving Forward

4. Move control stick forward gradually to move machine forward. The angle of control stick controls machine speed.

Moving Backward

5. Move control stick backward gradually to move machine backward. The angle of control stick controls machine speed.

NOTE

- See Specifications (page 13) for the speed range.

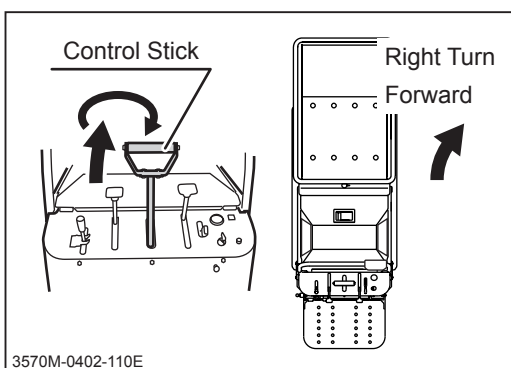

Turning while Traveling Forward

6. Move control stick gradually forward and twist it right (clockwise) to turn right.

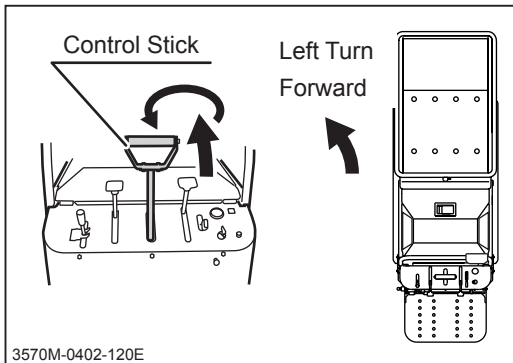

7. Move control stick gradually forward and twist it left (counter-clockwise) to turn left.

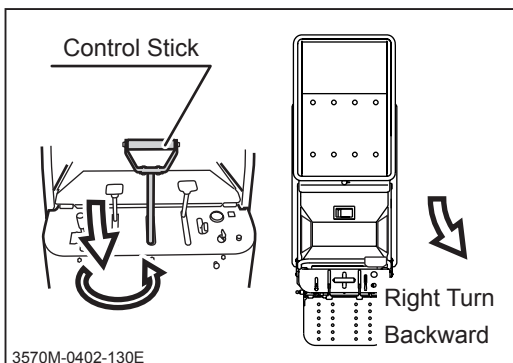

Turning while Traveling Backward

8. Move control stick gradually backward and twist it left (counter-clockwise) to turn right.

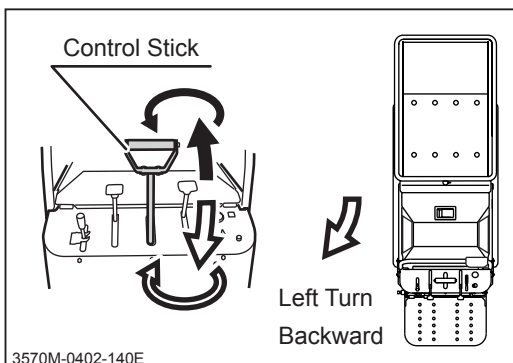

9. Move control stick gradually backward and twist it right (clockwise) to turn left.

Stopping

⚠ WARNING!

- Do not make a sudden stop. The machine may skid or tip over.
- Always park on a firm, level place. Never park on a potentially dangerous place.

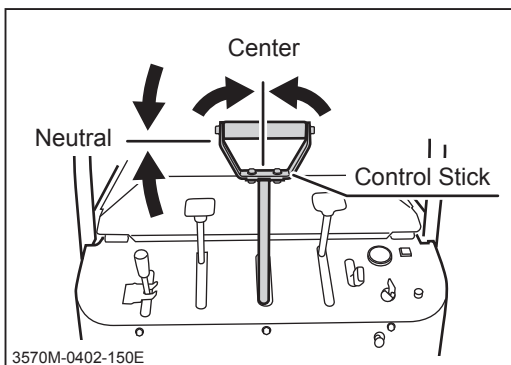

1. Move control stick gradually to the neutral and centered (not twisted) position.

Parking

⚠ WARNING!

- Always park on a firm, level place. Never park on a potentially dangerous place.
- Do not park on a slope. If it is absolutely necessary to park the machine on a slope, make certain to apply parking brake firmly and block the tracks with chocks.

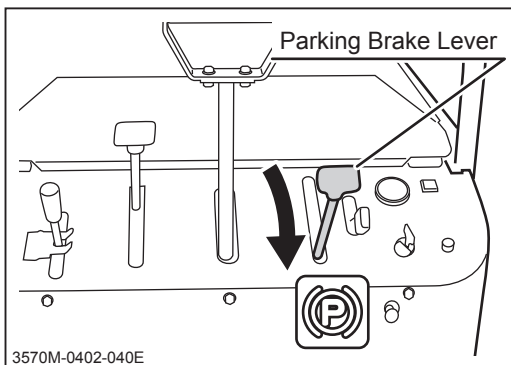

1. Stop machine.
2. Move parking brake lever to [(P) (engaged)] position.

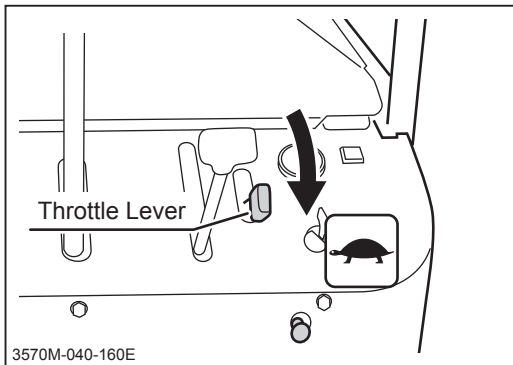

3. Move throttle lever toward [ (slow)] position to decrease engine speed.

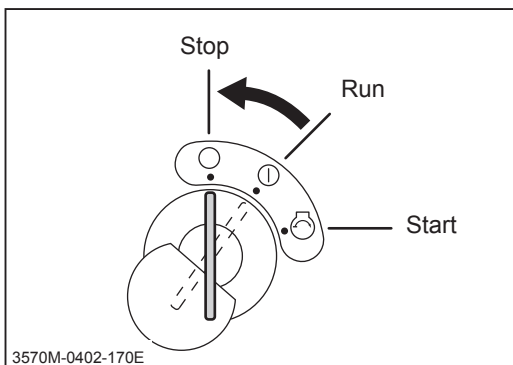

4. Turn main switch to [○ (off)] position.
Remove key from the main switch.

NOTE

- Leaving main switch in [| (on)] position drains battery and cause it to discharge.

Working

Dumping and Turning

⚠ WARNING!

- Always make certain of the safety of your surroundings when dumping or turning bucket.
- Never dump or turn bucket on a slope. Machine can tip over

⚠ CAUTION!

- Always run the engine when dumping or turning bucket.
- When lowering loaded bucket, slow engine speed and lower bucket gently.

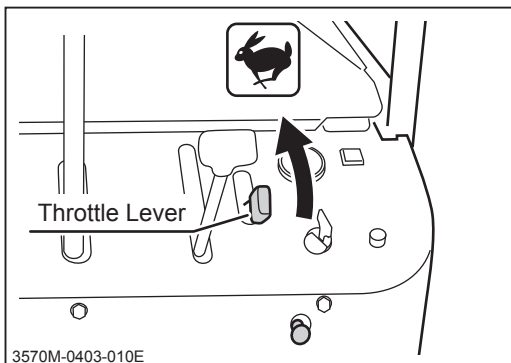

1. Move throttle lever to [🐇 (fast)] position to increase engine speed.

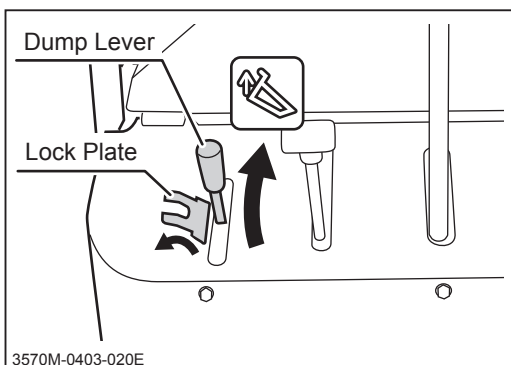

Raising Bucket with Dump Lever

2. Turn lock plate to the side so that dump lever can be moved.
3. Move dump lever gradually toward [🐇 (up)] to raise bucket.
4. When bucket reaches its upper limit, a hissing noise is heard; move dump lever back to [● (neutral)] position.

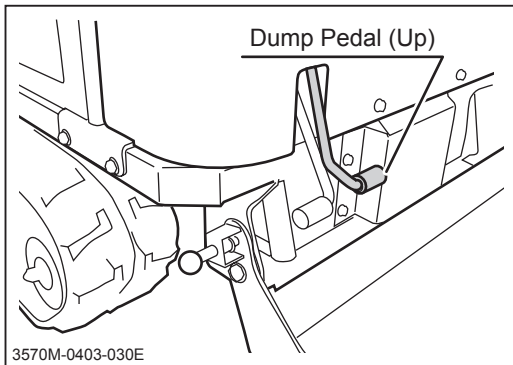

Raising Bucket with Dump Pedal

2. Turn lock plate on dump lever to the side so that dump lever can be moved. Dump pedal is linked to dump lever.
3. Step lightly on dump pedal (up) to raise bucket.
4. When bucket reaches its upper limit, a hissing noise is heard; release pedal.

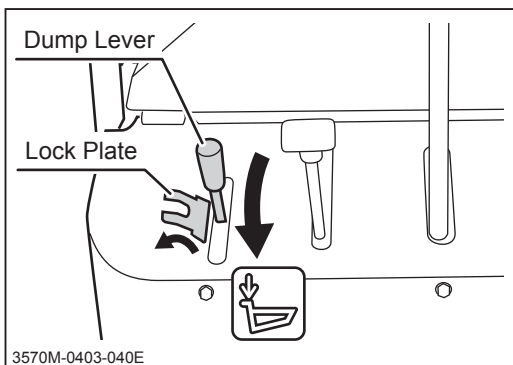

Lowering Bucket with Dump Lever

5. Move dump lever gradually toward [▾ (down)] to lower bucket.
6. When bucket reaches its lower limit, a hissing noise is heard; move dump lever back to [● (neutral)] position.
7. Turn lock plate back in place to lock dump lever.

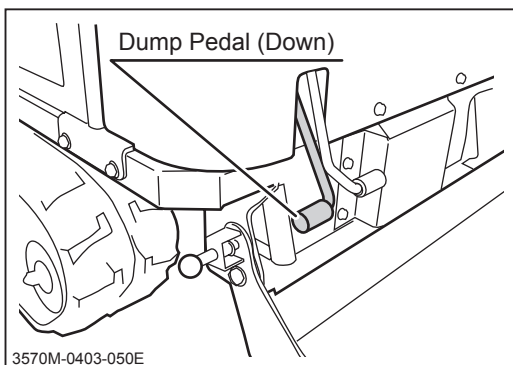

Lowering Bucket with Dump Pedal

5. Step lightly on dump pedal (down) to lower bucket.
6. When bucket reaches its lower limit, a hissing noise is heard; release pedal.
7. Turn lock plate back in place to lock dump lever.

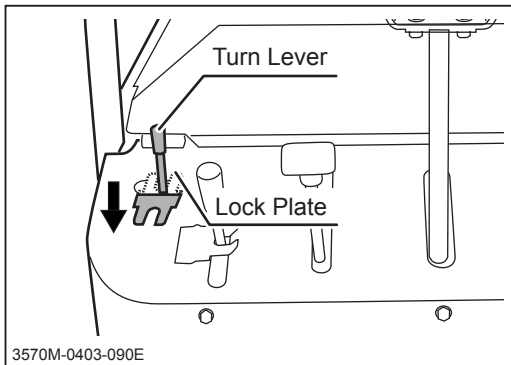

Turning (Turn and Dump Model)

1. Move throttle lever to [ (fast)] position to increase engine speed.
2. Remove lock plate from turn lever.

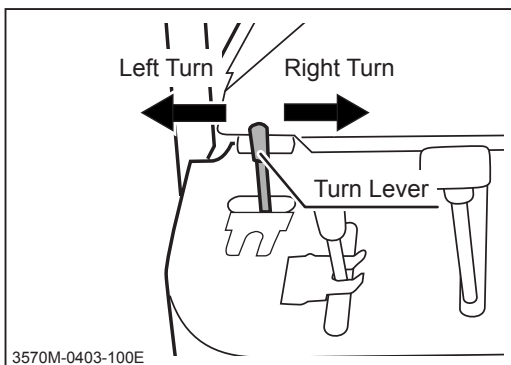

3. Move turn lever gradually to the desired direction.
4. When bucket reaches its maximum angle, a sensor stops turning, move turn lever back to [ (neutral)] position.
5. After turning operation is completed, lock lever with lock plate.

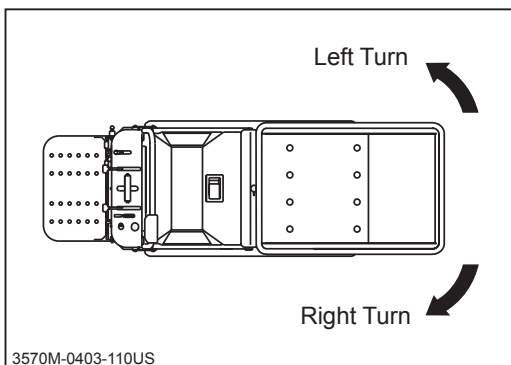

Using Safety Prop

⚠ WARNING!

- Place safety prop under bucket when inspecting or working under bucket.

⚠ CAUTION!

- Make certain to undo safety prop before lowering bucket.

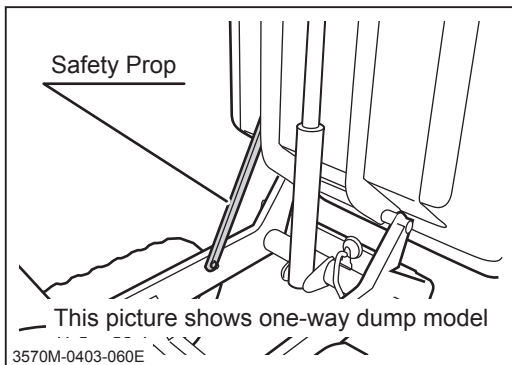

1. Raise bucket.
2. Hold bucket with safety prop.

Folding/Unfolding Step

⚠ WARNING!

- Hold step firmly when folding or unfolding step. Make certain that hands or fingers are not in the way to be caught by step when folding or unfolding.
- Make certain that step is securely locked with step lock in either position.

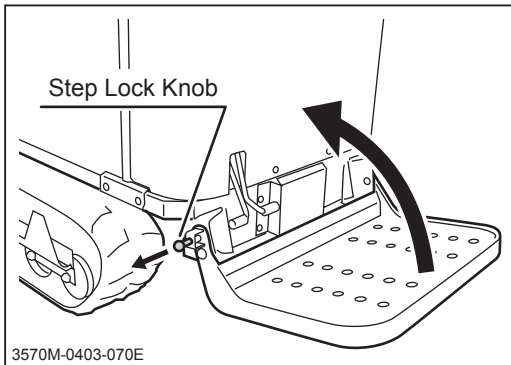

Folding Step

1. Pull step lock knob.
2. Fold step. Once step is fully folded, release step lock knob so that step locks in this position.

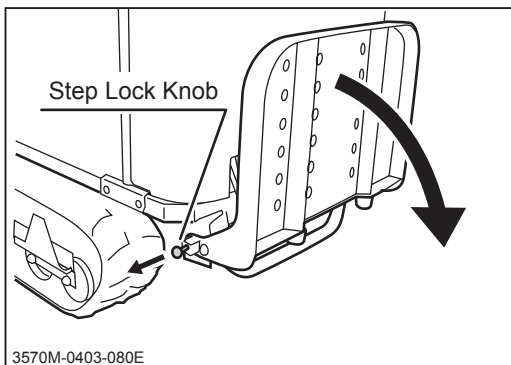

Unfolding Step

1. Hold step firmly and pull step lock knob.
2. Unfold step. Once step is fully unfolded, release step lock knob so that step locks in this position.

Maintenance Schedule

⚠️ WARNING!

- Follow the scheduled maintenance as described below. Failure to do so may result in mechanical or property damage, injury or death.

- Perform a pre-startup inspection (PSI) before each use, a monthly inspection once a month, and a yearly inspection once a year.
- Some maintenance procedures described below may require special knowledge or tools and instruments. Contact your CANYCOM representative to perform such procedures.

Item	Description	Schedule			Note	
		PSI	Mon	Year		
Engine General	Starting	Engine shall start easily without making any irregular noise.	√	√	√	
	Running	Engine speed shall be set properly at idle and at full without loading. Engine shall stay running smoothly.		√	√	Contact your CANYCOM representative for inspection.
		When accelerating engine, throttle lever shall move smoothly, and engine shall accelerate smoothly without stopping or knocking.	√	√	√	
	Exhaust	Warm up engine thoroughly, and observe exhaust sound and gas from idle to fast speed; exhaust sound shall be normal and no smoke shall be observed.	√	√	√	
		There shall be no leak in exhaust system or muffler.		√	√	
	Air Cleaner	Air cleaner case shall not be deformed or cracked. Case lid and connecting air hose shall be firmly in place.		√	√	
		Cleaner element shall be in good shape without damage or excessive dust.		√	√	Cleaning/Replacing: Page 40
	Fasteners	Bolts and nuts fastening cylinder head, intake and exhaust manifolds shall be tightly fastened. * this may be skipped if there is no gas or water leak found in these areas.			√	

Item		Description	Schedule			Note	
			PSI	Mon	Year		
Engine	General	Valve Clearance			√	Contact your CANYCOM representative for inspection.	
		Compression			√	Contact your CANYCOM representative for inspection.	
		Engine Mount	Engine base shall be free of cracks or deformation.	√	√	√	
	Mounting bolts and nuts shall not be loose or missing.		√	√	√		
	Lubrication System	Oil shall be clean and at correct level.	√	√	√	Inspecting/Changing: Page 38	
		No noticable oil leak shall be found in head cover, oil pan, or pipes.	√	√	√		
	Fuel System	There shall not be any leak in fuel tank, hoses, or pipes.	√	√	√		
		Fuel hoses shall be free of damage or deterioration.	√	√	√		
		Fuel filter shall not be excessively dirty or clogged.		√	√		
		There shall not be sediments or water in the fuel tank.		√	√		
	Electrical System	Spark Plugs	Electrodes shall not be worn, and there shall not be excessive carbon deposit.			√	Cleaning/Replacing: Page 41
		Charge System	Battery shall be charged.			√	Contact your CANYCOM representative for inspection.
		Battery	Battery electrolyte level shall be correct.		√	√	Inspecting/Filling: Page 55
			Terminals shall be free of marked corrosion and are tightly secured.		√	√	
		Wiring	Connections shall be securely connected.		√	√	
	Wiring shall be free of damages.			√	√		
	Drivetrain	Clutch	Clutch shall not make noise and shall disengage completely when operated at idle.		√	√	
			Clutch shall not slip and engage smoothly.		√	√	

Item	Description	Schedule			Note	
		PSI	Mon	Year		
Drive Train	Drive Belts	Belt tension shall be properly adjusted.		√	√	Inspecting/Adjusting: Page 47
		Belt shall be free of damages, excessive wear, or dirt; shall be free of oil or grease.		√	√	
	Transmission	Irregular noise or overheating shall not be observed.	√	√	√	
		Oil shall be clean and filled to a proper level.		√	√	Replacing: Page 45
		There shall not be oil leak in or around transmission.		√	√	
	HST Pump	Drive the machine forward and backward, turn left and right in both directions; machine shall move normally and free of irregular noise or overheating.	√	√	√	
		Hydraulic fluid shall be filled to a proper level.		√	√	Inspecting/Changing: Page 43
		Hydraulic fluid shall be clean and free of dirt or contamination.		√	√	Inspecting/Changing: Page 43
		There shall be no fluid leak in or around fluid tank.		√	√	
	Linkage	Rods, links, and wires in linkage shall be free of deformation or damage.		√	√	
		Connections shall be free of looseness, excessive play, or missing cotter pins.		√	√	
	Undercarriage	Wheels Sprockets Idlers	Shall be free of cracks, defromation, or excessive wear.	√	√	√
There shall not be excessive play in axle. Irregular noise or overheating shall not be observed when traveling.			√	√	√	
Mounting bolt or nut shall not be loose or missing.			√	√	√	
There shall be no oil leak in or around axle.				√	√	
Tracks		There shall not be marked cut, deterioration, or wear.	√	√	√	
		Track shall be properly tensioned; shall not be too loose or too tight.	√	√	√	Adjusting: Page 42
		Tension bolt shall be free of deformation or corrosion.	√	√	√	

Item	Description	Schedule			Note	
		PSI	Mon	Year		
Brake System	Parking Brake	Parking brake shall work properly.	√	√	√	Adjusting: Page 48
		Parking brake shall be able to hold the machine on a 20-degree slope.		√	√	
	Linkage	Rods, links, and wires in linkage shall be free of deformation or damage.		√	√	
		Connections shall be free of looseness, excessive play, or missing cotter pins.		√	√	
Hydraulic System	Hydraulic Pump	There shall be no leak in or around hydraulic pump.		√	√	
		Fastening bolts and nuts shall not be loose or missing.		√	√	
		No irregular vibration, noise, or heat shall be observed when hydraulic pump is in operation.		√	√	
		Amount and pressure of discharge under load shall be within the standard range specified by the manufacturer. *this may be skipped if irregular vibration, noise, or heat described above is not observed.			√	
	Hydraulic Valve	There shall be no leak in or around hydraulic valve.		√	√	
	Hydraulics Belt	Belt tension shall be properly adjusted.		√	√	Inspecting/Adjusting: Page 54
		Belt shall be free of damages, excessive wear, or dirt; shall be free of oil or grease.		√	√	
	Plumbing	Plumbing shall be free of cracks, damages, twists, or deterioration.		√	√	
		There shall be no leak in pipes, hoses, joints, or seals.		√	√	
		Plumbing shall be mounted properly, and fastening bolts and nuts shall not be loose or missing.		√	√	
		Breather shall not be clogged.		√	√	

Item	Description	Schedule			Note	
		PSI	Mon	Year		
Hydraulic System	Hydraulic Cylinder	Shall work smoothly.		√	√	
		There shall be no leak when extending and contracting cylinder.		√	√	
		Extend cylinder fully under load and hold. Stroke shall be within the range specified by manufacturer.			√	
		Cylinder tube and rod shall be free of dents, cracks, bends, or scratches.		√	√	
		Cylinder mounting pins shall be free of damages or excessive wear.		√	√	
Body, Chassis, Loading Deck	Chassis Frame	Shall be free of cracks, deformation, or corrosion.		√	√	
		Fastening bolts or nuts shall not be loose or missing.		√	√	
	Body Panels	Shall be free of cracks or deformation.		√	√	
		Doors shall open, close, and lock properly.	√	√	√	
		Fastening bolts or nuts shall not be loose or missing.		√	√	
	Loading Deck Bucket	Loading deck shall be raised and lowered smoothly.		√	√	
		Shall be free of cracks, deformation, or corrosion.		√	√	
		Fastening bolts or nuts shall not be loose or missing.		√	√	
	Safety Prop	Safety prop shall be free of any deformation.		√	√	
	Labels	Warning labels and instruction plates shall be clean, legible, and free of damages.	√	√	√	
Safety Devices	Work Lamp	Work lamp shall work.	√	√	√	
		Lamp lens shall be free of cracks or chipping and water shall not be in the lamp.		√	√	
	Horn	Horn shall work.	√	√	√	

5

Maintenance

List of Fluids and Lubricants

Item	Schedule	Grade	Cap.	Ref.
Fuel	As needed.	Automotive Unleaded Gasoline	20 L	Page 14
Engine Oil	Fill Inspect daily. Fill as needed. Change Initially - After 8 hours of use. Every 50 hours afterwards.	Engine Oil API rating: SE or better. SAE rating: 10W-30	1.4 [1.55]L	Page 38
Transmission Oil	Change Initially - After 50 hours of use. Every 100 hours afterwards.	Gear Oil API rating: GL-4 or 5 SAE rating: 80	2.0L	Page 45
HST Fluid	Change Initially - After 50 hours. Every 500 hours afterwards.	High viscosity index hydraulic fluid, ISO VG46	23L	Page 43
Battery Electrolyte	Inspect daily.	Distilled Water	-	Page 55

* Numbers in the square brackets [] indicate the capacity including the oil filter cartridge.

Greasing and Lubrication Points

Point	Schedule	Grade	Cap.	Ref.
Greasing Points	6 months after the purchase. Every 6 months afterwards.	Chassis Grease	-	Page 52
Lubrication Points	6 months after the purchase. Every 6 months afterwards.	Gear Oil API rating: GL-4 or 5 SAE rating: 80	-	Page 52

List of Consumables and Spares

Item	Part No.	Schedule	Qty.	Ref.
Engine				
Air Cleaner Element	-	Inspect every 50 hours. Replace if defective.	1	Page 40
Oil Filter	-	Initially: 50 hours. Every 150 hours afterwards.	1	Page 40
Spark Plug(NGK BP6ES)	-	Replace if defective.	2	Page 41
Drive Train				
Drive Belt (SB48)	08521500048	Replace if defective.	2	Page 47
Track	35702021000	Replace if defective.	2	Page 42
Brake Lining	73014007000	Replace if defective. (Replace in pairs)	2	Page 48
Suction Filter	36636029000	Every 500 hours.	1	Page 44
Line Filter	35706161000	Every 500 hours.	1	Page 44
Hydraulic Hose (HST)	-	Every 2 years or if defective.	1 Set	
Electrical System				
Battery (40B19R)	37053901000	Replace if defective.	1	Page 55
Fuse 5A	-	Replace if defective.	3	Page 57
Fuse 10A *1	-	Replace if defective.	1	Page 57
Fuse 30A	-	Replace if defective.	1	Page 57
Hydraulic System				
Hydraulics Belt (LA35)	08511600035	Replace if defective.	1	Page 54
Hydraulic Hose (Dump)	-	Every 2 years or if defective.	1 Set	
Hydraulic Hose (Oil Cooler)	-	Every 2 years or if defective.	1 Set	
Hydraulic Hose (Turn)*1	-	Every 2 years or if defective.	1 Set	

*1 Turn and Dump Model Only

NOTE

- Rubber products such as the hydraulic hose deteriorate over time. Replace them every 2 years.
- Track wear limit: 5mm of lug height

Removing and Installing Body Panels

⚠ CAUTION!

- Cut or pinch hazard exists when removing or installing body panels; beware of sharp edges and pinch points.
- Make certain to reinstall panels after removing for repairs or inspection.

Engine Compartment

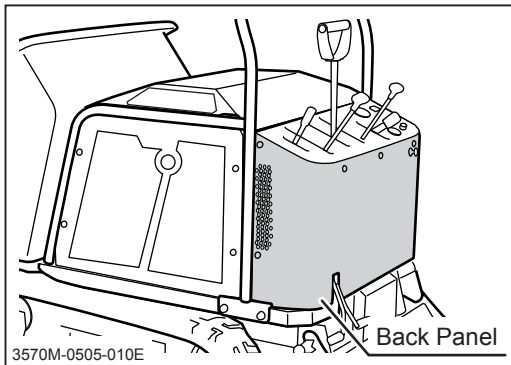

Removing Back Panel

1. Unfasten (9) bolts to remove back panel.

Installing Back Panel

1. Hold back panel in place and fasten bolts to install back panel.

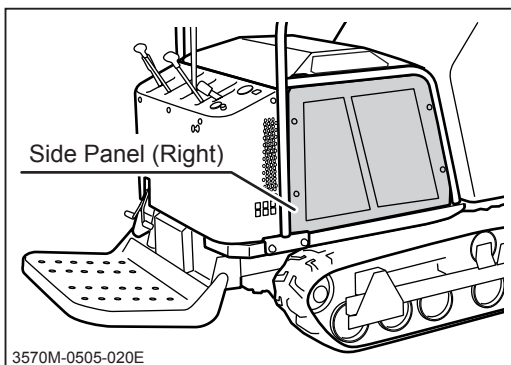

Removing Side Panel (Right)

1. Unfasten (4) bolts to remove right side panel.

Installing Side Panel (Right)

1. Hold right side panel in place and fasten bolts to install right side panel.

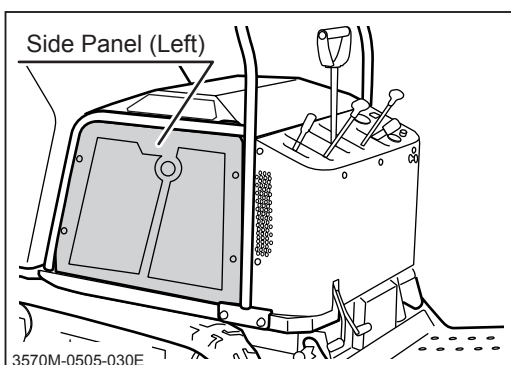

Removing Side Panel (Left)

1. Unfasten (4) bolts to remove left side panel.

Installing Side Panel (Left)

1. Hold left side panel in place and fasten bolts to install left side panel.

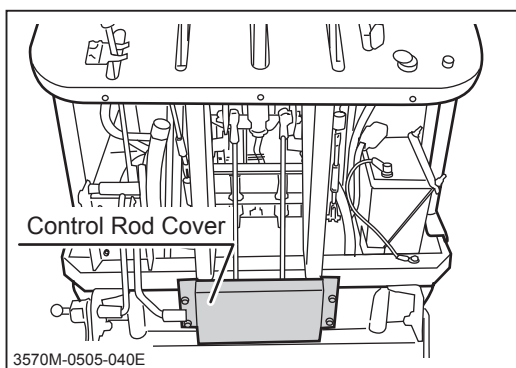

Removing Control Rod Cover

1. Remove back panel. (Page 36)
2. Unfasten (4) bolts to remove control rod cover.

Installing Control Rod Cover

1. Hold control rod cover in place and fasten bolts to install control rod cover.
2. Install back panel. (Page 36)

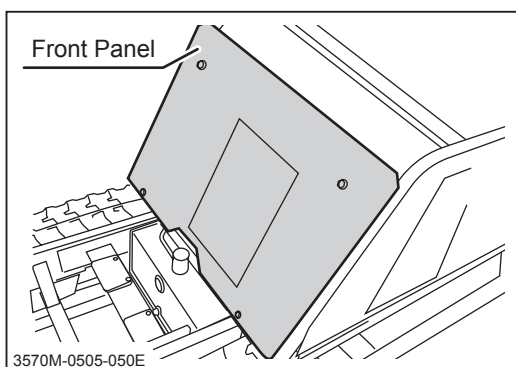

Removing Front Panel

1. Raise bucket.
2. Hold bucket with safety prop.
3. Unfasten (4) bolts to remove front panel.

Installing Front Panel

1. Hold front panel in place and fasten bolts to install front panel.
2. Undo safety prop and lower bucket.

Engine

⚠ WARNING!

- Always stop engine before servicing.
- An engine that has been running is very hot. Allow engine to cool before servicing, or severe burns may result.

Engine Oil

⚠ CAUTION!

- Dispose of drained oil properly.
- Make certain to fill engine with correct grade of oil to the specified level. Insufficient amount or wrong grade of oil reduces performance and may cause permanent damage to engine.

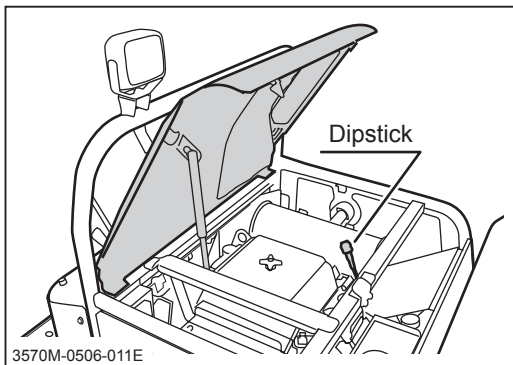

Inspecting

1. Park machine on a level surface.
2. Open engine hood

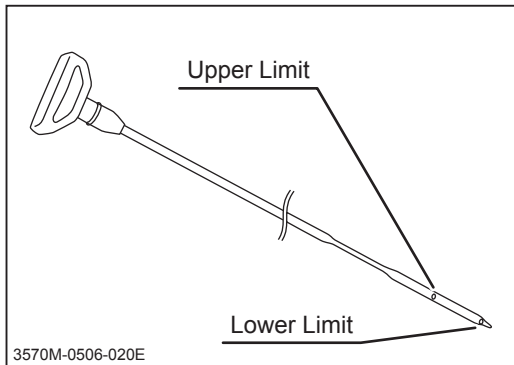

3. Pull out dip stick. Wipe oil off of dipstick with clean cloth.
4. Insert dipstick and pull it out again.
5. Check oil level. Oil level should be between two dimples indicating upper and lower limits. If the level is low, fill oil.
6. Visually inspect oil. If oil is dirty or its viscosity is not normal, change it.

NOTE

- To obtain correct reading, check oil level before starting, or wait about 10 minutes after stopping the engine to allow oil to drain back to the oil pan.
- Always check oil level on a level surface.

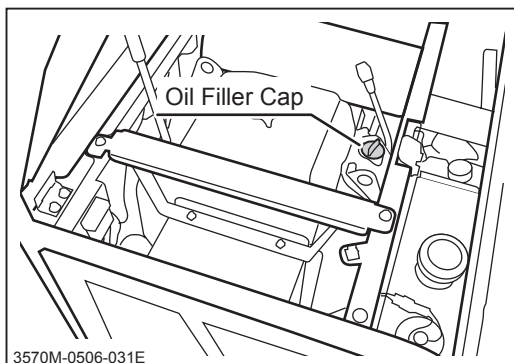

Filling

1. Remove oil filler cap.
2. Follow the instructions in the **Operator's Manual for the engine** to fill oil.
3. Check oil level.
4. Put oil filler cap back in place and tighten it securely.

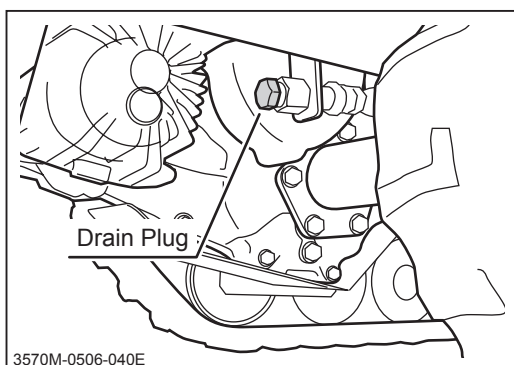

Changing

1. Have an appropriate oil drain pan.
2. Remove drain plug to drain oil.
3. Put drain plug back in place and tighten it securely.
4. Fill oil.

NOTE

- Oil Capacity: 1.4L [1.55L when changing the oil filter cartridge].
- Removing oil filler cap helps drain oil faster.

Oil Filter

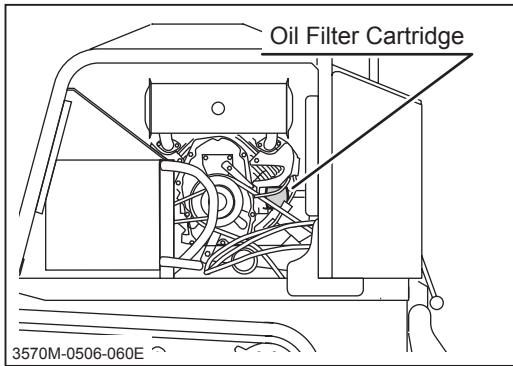

1. Remove left side panel and back panel. (Page 36)
2. Drain oil. (Page 38)
3. Follow the instructions in the **Operator's Manual for the engine** to change oil filter cartridge.
4. Fill oil. (Page 38)
5. Run engine and make sure that there is no leak at the filter mount.
6. Install panels back in place.

Air Cleaner

⚠ CAUTION!

- Clean air cleaner element regularly. Dirty cleaner element reduces engine performance and life.
- Replace the cleaner element if damaged.

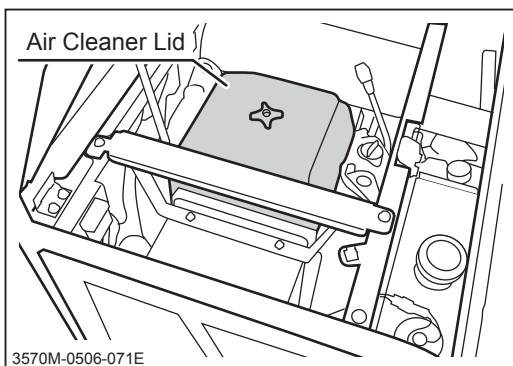

1. Open engine hood.
2. Remove air cleaner lid.

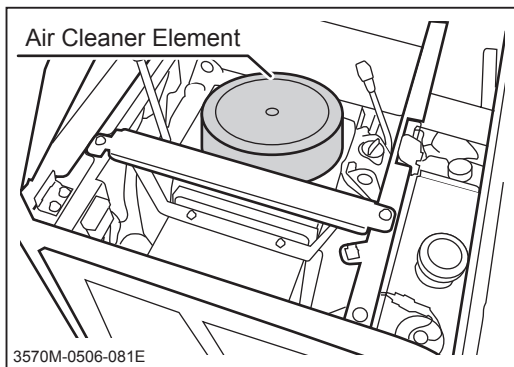

3. Remove air cleaner element.
4. Follow the instructions in the **Operator's Manual for the engine** to clean or change air cleaner element.
5. Put air cleaner element and air cleaner lid back in place.
6. Push engine hood until it latches to close.

Spark Plugs

⚠ CAUTION!

- Never pull ignition cable when removing a spark plug cap. Conductor in the cable may be severed or damaged.
- If a spark plug is damaged, replace it with a new one.

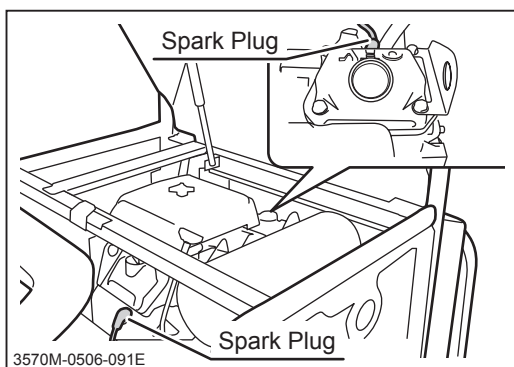

1. Open engine hood and hold it in place with engine hood stay.
2. Remove spark plug caps and spark plugs. Spark plugs are located in the front and rear of engine.
3. Follow the instructions in the **Operator's Manual for the engine** to inspect, clean, or change spark plugs.
4. Install spark plugs and spark plug caps. Undo engine hood stay and close engine hood.

Drive Train

⚠ WARNING!

- Stop engine when servicing the drive train.
- Allow machine to cool off before servicing. Engine is very hot after operation and may pose a burn hazard.

Tracks

⚠ WARNING!

- Support machine securely on a firm, level surface with jack stands when servicing.
- Make certain to adjust track tension properly. Improperly tensioned tracks may wear or come off, resulting in property damage, serious injury or death.

NOTE

- Track stretches during its use-life. Inspect and adjust regularly.

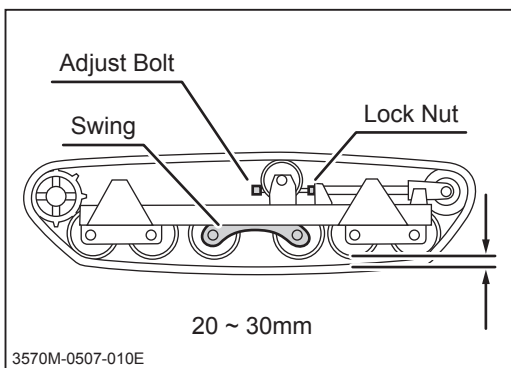

Inspecting

1. Jack up and support machine parallel to the ground.
2. Inspect the clearance between track and the second wheel to be between 20 and 30mm. Adjust tracks if the clearance is not within this range.
3. Lower machine.

NOTE

- Jack up rear axle for rear side and cross member for front side.

Adjusting

1. Jack up and support machine parallel to the ground.
2. Loosen lock nut.
3. Adjust track with adjust bolt so that the clearance between track and the wheels at the furthest are between 20 and 30mm.
4. Tighten lock nut
5. Lower machine.

HST (HydroStatic Transmission) Fluid

⚠ CAUTION!

- Dispose of drained fluid properly, according to the national and local regulations.

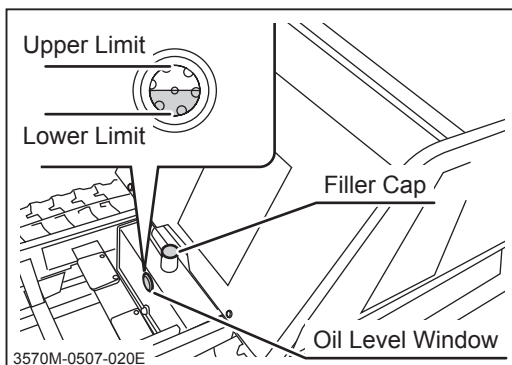

Inspecting/Filling

1. Park machine on a level ground.
2. Lift bucket and hold bucket with safety prop. (Page 27) Lock dump lever with lock plate.
3. Visually inspect oil level window.
4. If the level is low, open filler cap and fill fluid. Put filler cap back in place.
5. Undo safety prop. Lower bucket.

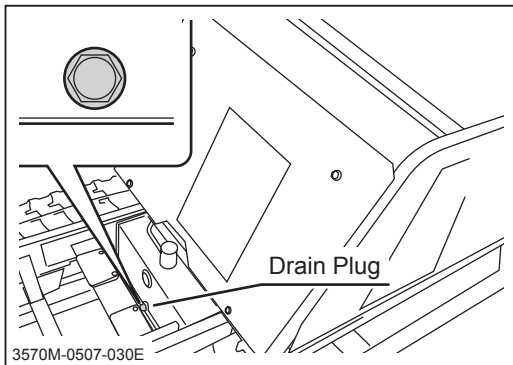

Changing

1. Have an appropriate oil drain pan.
2. Lift bucket and hold bucket with safety prop. (Page 27) Lock dump lever with lock plate.
3. Remove drain plug to drain fluid.
4. Wipe drain plug and drain hole clean. Put drain plug back in place. Tighten it securely.
5. Open filler cap to fill fluid. Put filler cap back in place.
6. Undo safety prop and lower bucket.
7. Start engine and engage clutch to circulate the fluid.
8. Inspect the fluid level.

Line Filter and Suction Filter

⚠ CAUTION!

- **Burn hazard; pay special attention when handling the hydraulic fluid. Hot fluid may cause burns.**

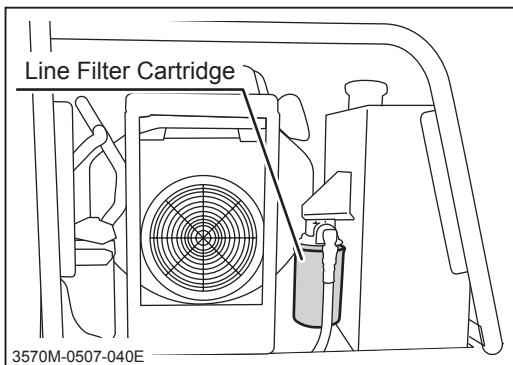

Changing Line Filter

1. Remove right side panel (Page 36).
2. Drain HST fluid. (Above, "Changing")
3. Remove line filter cartridge with an oil filter wrench.
4. Have a new line filter cartridge. Apply clean hydraulic fluid (oil) on cartridge oil seal evenly.
5. Screw in the new line filter cartridge. Tighten it by hand until cartridge is firmly in place.
6. Fill HST fluid.
7. Start engine and engage clutch to circulate the fluid. Watch for a leak.
8. Install right side panel. (Page 36)

NOTE

- Replace both line filter cartridge and suction filter element when hydraulic fluid is changed.
- Do not use the filter wrench when tightening filter cartridge. Tighten it by hand.

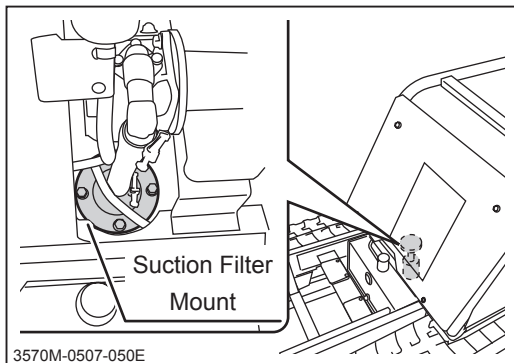

Changing Suction Filter

1. Park machine on a level ground.
2. Lift bucket and hold bucket with safety prop. (Page 27) Lock dump lever with lock plate.
3. Remove front panel. (Page 37)
4. Undo the bolts and remove suction filter mount.
5. Unfasten suction filter with a wrench and install a new filter. Tighten it securely.
6. Coat O-ring with hydraulic fluid evenly and insert suction filter mount in tank. Make sure to insert it straight so that O-ring does not get out of groove. Fasten suction filter mount with bolts.
7. Install front panel. (Page 37)
8. Undo safety prop. Lower bucket.

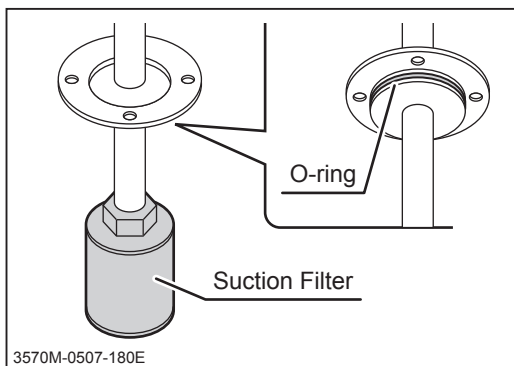

NOTE

- Replace both line filter cartridge and suction filter element when hydraulic fluid is changed.

Transmission Oil

⚠ WARNING!

- Always park machine on a level surface and block tracks with chocks when working under machine.

⚠ CAUTION!

- **Dispose of the drained oil properly, according to the national and local regulations.**

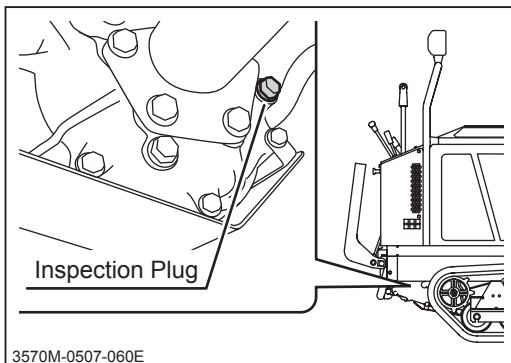
**Inspecting**

1. Park machine on a level ground.
2. Remove inspection plug and inspect if the oil level is at inspection hole. Fill oil if the level is low.
3. Visually inspect the condition of the oil. If dirty, change it.
4. Visually inspect seal washer on inspection plug.
5. Clean inspection plug and seal washer. Put inspection plug back in inspection hole and tighten it securely.

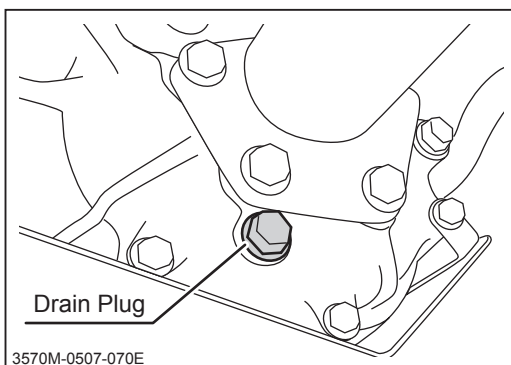
**Draining**

1. Have an appropriate oil drain pan.
2. Remove back panel. (Page 36)
3. Remove drain plug to drain the oil.
4. Put drain plug back in place and tighten it securely.

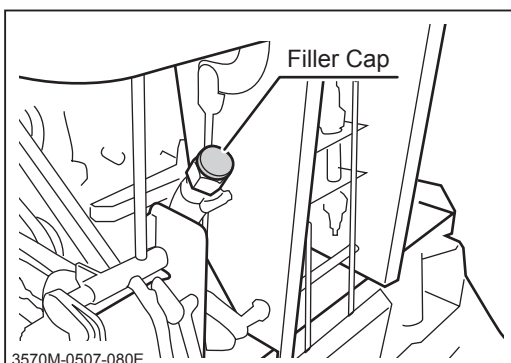
**Filling**

1. Remove back panel. (Page 36)
2. Remove filler cap and fill a sufficient amount of oil.
3. Inspect oil level.
4. Put filler cap back in place.
5. Install back panel. (Page 36)

NOTE

- **Oil Capacity: 2.0L**

Drive Belts

⚠ CAUTION!

- Adjust belt tension properly. Improperly tensioned belts may reduce performance and its service life.

Inspecting

1. Remove left side panel (Page 36)
2. Move clutch lever to [⚙ (disengaged)] position.
3. Visually inspect the belts. Replace the belt if damaged.
4. Install left side panel back in place. (Page 36)

NOTE

- Contact your CANYCOM representative when the belt needs to be replaced.

Adjusting

1. Remove back and left side panels. (Page 36)
2. With two wrenches, loosen lock nuts that lock turnbuckle on the clutch linkage.
3. Move clutch lever to [⚙ (engaged)] position.
4. Adjust turnbuckle so that the inside dimension between spring hooks is between 111 and 114 mm.
5. Tighten lock nuts with two wrenches.
6. Install back and left side panels back in place. (Page 36)

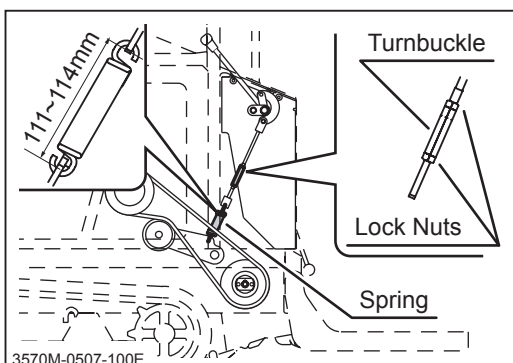
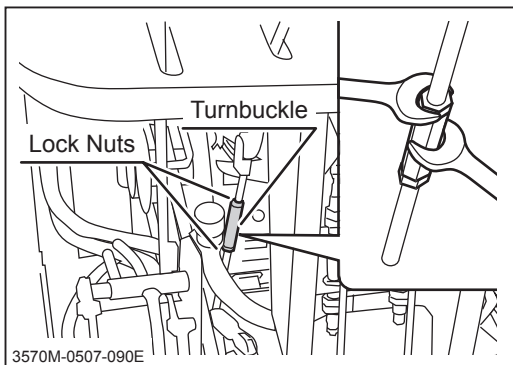

Belt Stoppers

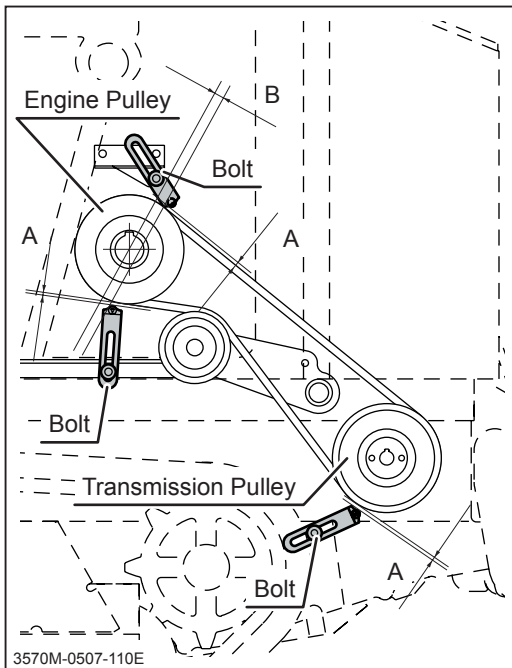

Adjusting

1. Remove left side panel. (Page 36)
2. Move clutch lever to [ (engaged)] position.
3. Loosen the bolts that fasten belt stoppers. Adjust belt stoppers so that the gap A, the distance between belt stopper pins and the belt, is 5-6mm, and the gap B, the distance between the center of engine pulley and the line connecting belt stopper pins by engine pulley, is 10-20mm. Tighten the bolts securely.
4. Start engine and observe if the belt runs smoothly without rubbing pins. Stop engine.
5. Install left side panel in place. (Page 36)

Parking Brake

⚠ WARNING!

- Always keep brake adjusted for maximum performance. Improperly adjusted brake may result in property damage, serious injury, or death.

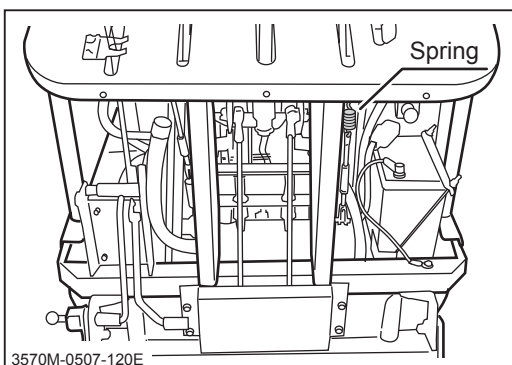

Inspecting

1. Make certain control stick is in the neutral and centered position.
2. Move brake lever to [(P) (engaged)] position.
3. Remove back panel. (Page 36)

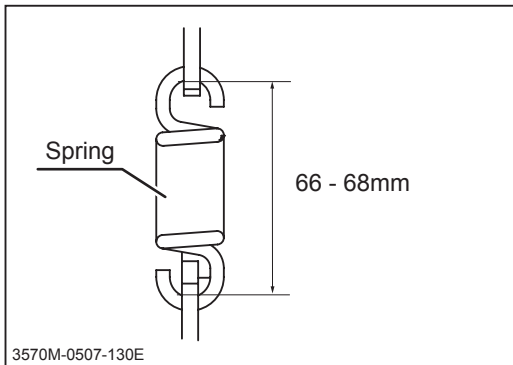

3. Locate spring on the brake linkage. Measure the distance between the spring hooks; the distance shall be between 66 and 68mm .
4. Install back panel back in place. (Page36)

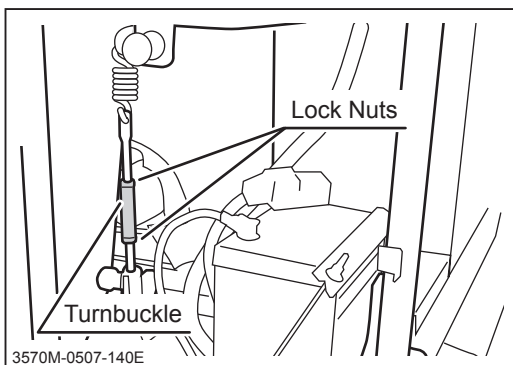

Adjusting

1. Make certain control stick is in the neutral and centered position.
2. Move brake lever to [(P) (engaged)] position.
3. Remove back panel. (Page 36)
4. Loosen lock nuts.
5. Adjust turnbuckle so that the distance between the spring hooks shall be between 66 and 68mm.
6. Tighten lock nuts securely.
7. Install back panel back in place. (Page 36)

Control Stick

NOTE

- Control stick is properly adjusted at the time of shipment. Adjustment is needed only when transmission, control stick itself, or its linkage is replaced or dismantled.

Inspecting

1. Start engine and increase the engine speed by moving throttle lever to [ (fast)] position.
2. Operate machine on a level surface and release control stick; if track moves forward or backward, the control stick needs to be adjusted.

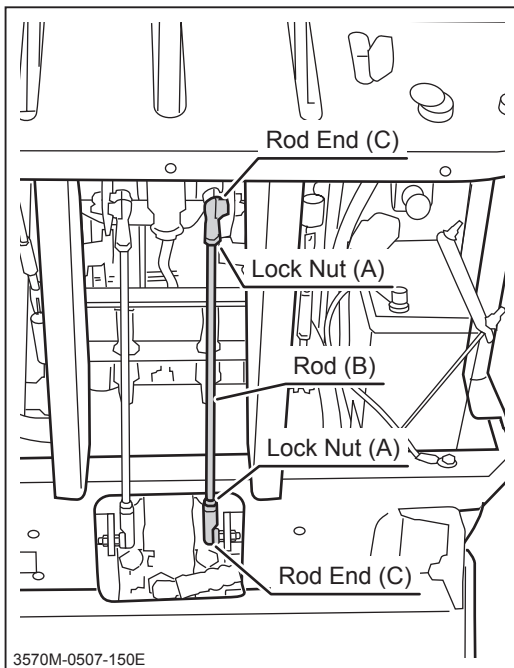

Adjusting - When Right Track Moves

3. Remove back panel and control rod cover. (Page 36, 37)
4. Loosen lock nuts (A).
5. Rotate rod (B) until right track does not move.
 - When track moves forward, turn rod so that the distance between rod ends (C) becomes longer.
 - When track moves backward, turn rod so that the distance between rod ends (C) becomes shorter.
6. Tighten lock nuts (A) securely.

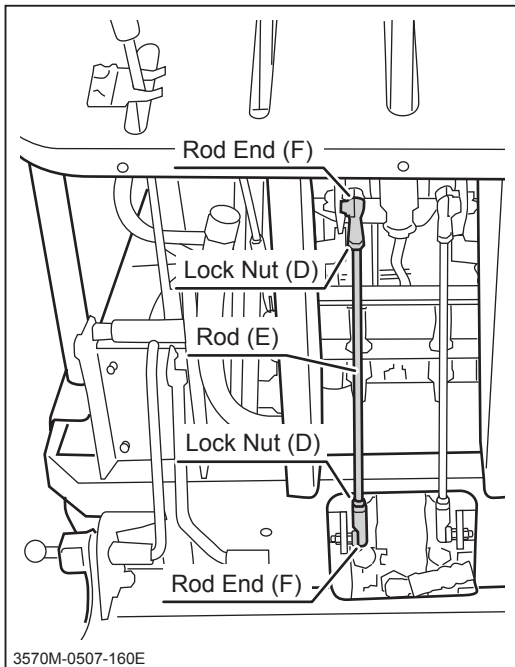

Adjusting - When Left Track Moves

7. Loosen lock nuts (D).
8. Rotate rod (E) until left track does not move.
 - When track moves forward, turn rod so that the distance between rod ends (F) becomes longer.
 - When track moves backward, turn rod so that the distance between rod ends (F) becomes shorter.
9. Tighten lock nuts (D) securely.
10. Install control rod cover and back panel.
(Page 36, 37)



Greasing and Lubricating

⚠ CAUTION!

- Follow the maintenance schedule to grease and lubricate machine. Lack of grease or lubrication may result in rust, excessive wear or seizure.



1. Grease and lubricate the greasing and lubricating points.

One-way Dump

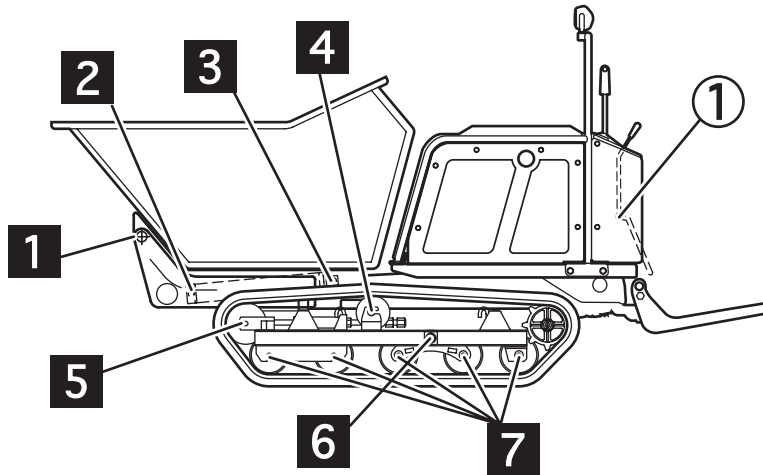
Greasing Points		Lubricating Points
		
1	5	①
2	6	
3	7	
4		



Turn and Dump

Greasing Points		Lubricating Points
		
1	5	①
2	6	
3	7	
4	8	

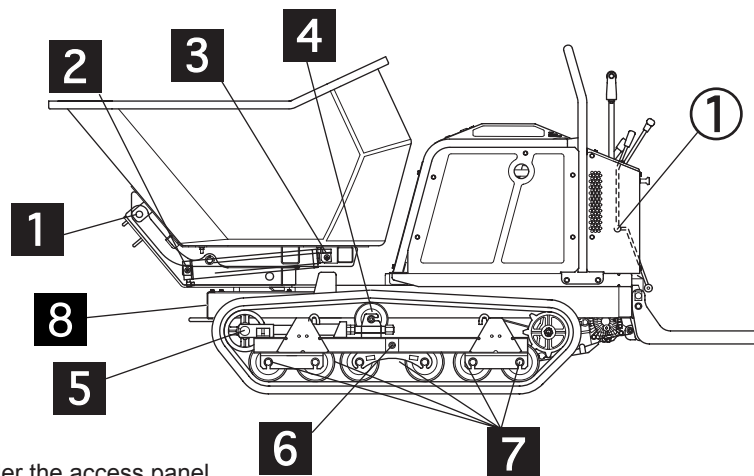

* 8 is under the access panel.

3570M-0507-171E

NOTE

- Grease and lubricant to use: Page 34
- When using a manual grease gun, pump 5-6 times. When the handle of the gun becomes heavy, stop pumping immediately.
- When using a pneumatic grease gun, pump it for a few seconds.

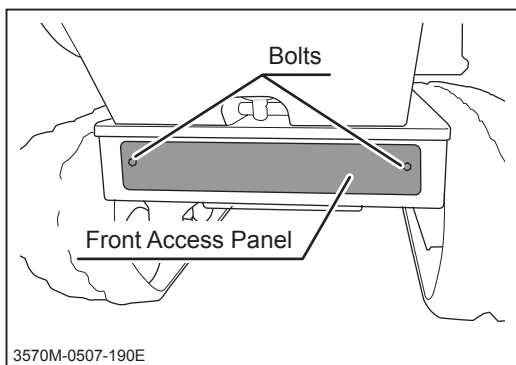

1. Remove 2 bolts fixing front access panel and remove front access panel.
2. Apply grease connecting a grease gun with grease nipple.
3. Install front access panel back in place.

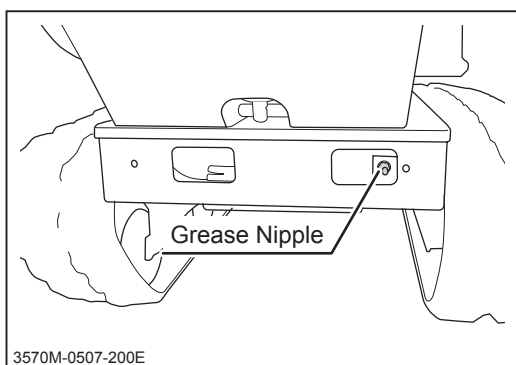

Hydraulic System

Hydraulics Belt

⚠ CAUTION!

- Adjust belt tension properly. Improperly tensioned belts may reduce performance and its service life.

Inspecting

1. Remove left side panel. (Page 36)
2. Visually inspect belt. Replace belt if damaged.
3. Install left side panel back in place. (Page 36)

NOTE

- Contact your CANYCOM representative when belt needs to be replaced.

Adjusting

1. Locate tension arm spring. Loosen lock nut.
2. Adjust adjust nut so that the inside dimension between the spring hooks is between 65 and 68 mm.
3. Tighten lock nut.
4. Install left side panels back in place. (Page 36)

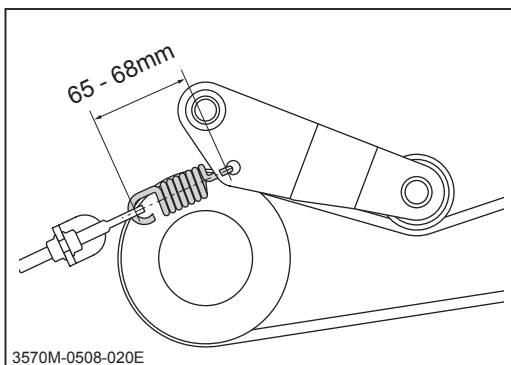
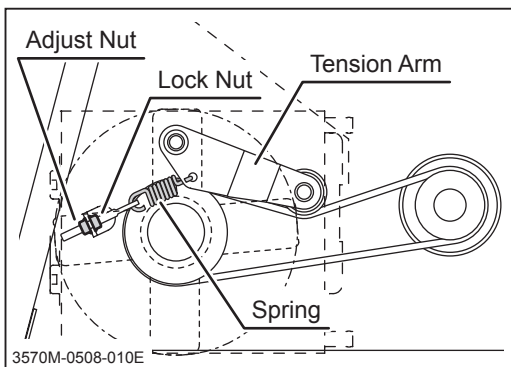

Electrical System

⚠ WARNING!

- Always stop engine and turn ignition switch to [○ (OFF)] position, and disconnect negative (-) terminal of battery when servicing the electrical system.

Battery

⚠ WARNING!

- Explosion hazard. Keep open flame or spark away from battery. Hydrogen gas generated during charging is extremely explosive.
- Battery fluid (diluted sulfuric acid) is corrosive and causes severe burns. Be extremely cautious when handling battery fluid. If battery fluid is spilled on clothes, immediately rinse with plenty of water. If spilled on skin or in an eye, immediately rinse with plenty of water and promptly consult a physician.
- Never charge battery when the fluid level is below the lower limit. Charging battery with insufficient fluid may shorten battery life or cause explosion.
- Never fill battery fluid beyond the upper limit. Battery fluid may spill and cause damage to the machine or personal injury.
- Always disconnect the (-) terminal first, and connect the (+) terminal first. Disconnecting or connecting in the opposite order may cause a short circuit.
- When installing the battery, make certain to connect the (+) and (-) terminals to their original positions. Avoid contact between terminals and other surrounding parts.

⚠ CAUTION!

- Always remove battery from machine before charging. Failure to do so causes damage to the electrical components and wiring.
- Follow the battery charger user's manual when charging.

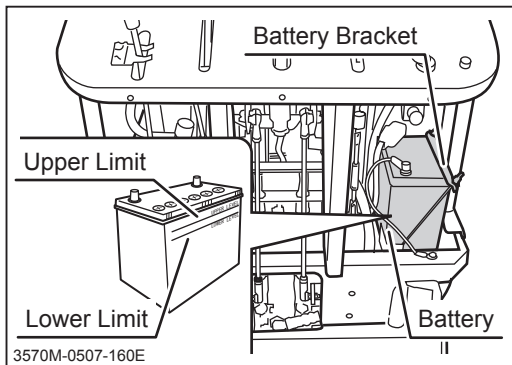

Inspecting

1. Park machine on a level ground.
2. Remove right side and back panels. (Page 36)
3. Visually inspect that the battery fluid level is between the "Upper Level" and "Lower Level" lines. If the fluid level is below the "lower Level," fill.

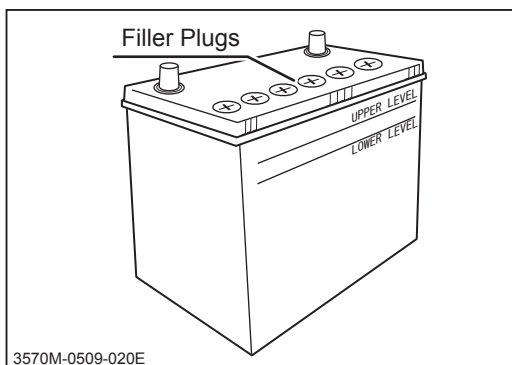

Filling

4. Remove battery bracket and battery from the machine.
5. Open filler plugs and fill distilled water in battery evenly until the fluid level is between the "Upper Level" and "Lower Level" lines.
6. Put filler plugs back in place.
7. Install battery.
8. Install right side and back panels. (Page 36)

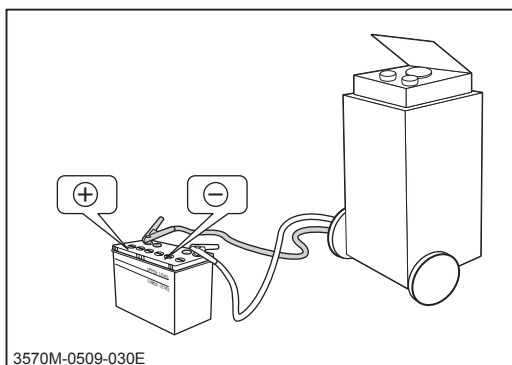

Charging

1. Remove right side and back panels. (Page 36)
2. Disconnect (-) cable from terminal.
3. Disconnect (+) cable from terminal.
4. Remove battery off machine.
5. Remove all filler plugs.
6. Follow the instructions in the battery charger user's manual to charge battery.

7. When battery is fully charged, put filler plugs back in place and install battery.
8. Connect (+) cable to terminal.
9. Connect (-) cable to terminal.
10. Install the right side and back panels. back in place.

NOTE

- Consider rapid charging as an emergency measure. This method uses a large amount of current to compensate the lost charge in a short time. However, battery needs to be fully charged in the ordinary method for a longer service life.

Fuses

⚠ CAUTION!

- If a fuse blows, investigate the cause before replacing. Always replace a fuse with the one of the correct rating.

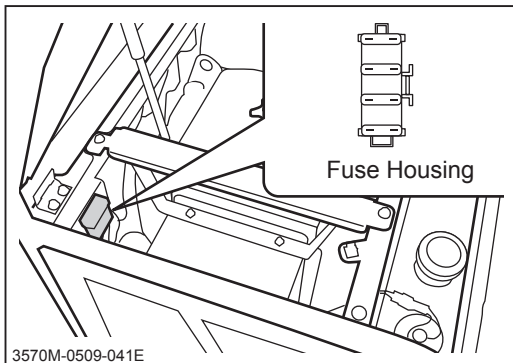

1. Open engine hood and hold it in place with engine hood stay.
2. Take lid off fuse housing.
3. Locate the blown fuse and replace it with a new one of the correct rating.
4. Put lid back in place.
5. Undo engine hood stay and close engine cover.

	5A	Work Lights
	5A	Hour Meter Oil Pressure Lamp
	5A	Fuel Cutoff Solenoid Relay Coils
	30A	Main

3570M-0509-060US

One-way Dump Model

	Main	30A	Spare 30A
	Fuel Cutoff Solenoid Relay Coils	5A	
	Hour Meter	5A	Spare 10A
	Oil Pressure Lamp	5A	
	Work Lights	10A	Spare 5A
	Swivel Hydro.Valve	5A	
	Spare	5A	

3570M-0509-062US

Turn and Dump Model

After Use Care

⚠ CAUTION!

- Do not wash engine, control panel, electrical parts, or tank caps with air breather with running water; water may enter inside and cause rust or damage.
- Clean machine after use; leaving dirt or foreign objects may cause damage.
- Do not attempt to move machine when it becomes inoperable due to freezing.

After Normal Use

1. Clean machine; take off of dirt, mud, and othe foreign matters after use.
2. If machine is to be left outside, cover machine with protective, water-proof covering after machine is cooled off.

After Cold Weather Use

1. Clean machine; remove dirt, mud, and othe foreign matters after use.
2. Park machine on a paved or firm, dry surface.
3. If machine is to be left outside, cover machine with protective, water-proof covering after it is cooled off.

Storage

⚠ WARNING!

- Fire hazard; do not store machine where there is a possibility of ignition.

⚠ CAUTION!

- Do not wash engine or control panel with running water; water may enter inside and cause rust or damage.
- Clean machine before storage; leaving dirt or foreign objects may cause damage.
- Do not store machine in a humid, dusty, or hot place.

1. Follow the instruction in **Parking** (page 22) to park machine.
2. Clean dirt off of machine.
3. Change engine oil (page 38).
4. Clean air cleaner (page 40).
5. Drain fuel tank.
6. Drain carburator.
7. Remove battery from machine. Service battery (page 55).
8. Cover machine with protective, water-proof covering after machine is cooled off.

NOTE

- Battery discharges even when it is not in use. A battery may hold charge for a few months, but it is a good practice to charge battery before it goes flat; it will extend the battery life.
- Refer to the Operation Manual for the engine, for detailed instructions on preparing engine for storage.

Troubleshooting

- If any malfunction or abnormal condition is found, immediately stop using the machine and take an appropriate measure according to the Troubleshooting chart below. If the malfunction or abnormal condition is not listed in the chart, or the suggested measure does not solve the problem, consult with your CANYCOM representative.
- Some corrective measures listed below require special knowledge and/or equipment. Please contact your CANYCOM representative in such a case.

Area	Malfunction	Possible Cause	Corrective Measure	Ref.
Engine	Engine does not start, or is difficult to start	Parking brake lever is engaged (in the (P) position - safety mechanism is working).	→Disengage the parking brake.	
		Battery is discharged.	→Add battery fluid. →Charge battery. →Replace battery.	Page 55
		Battery cable is disconnected.	→Connect battery cable.	
		Blown fuse.	→Replace fuse.	Page 57
		Bad connection or breakage in the wiring.	→Please contact your CANYCOM representative.	
		Out of fuel.	→Fill fuel.	Page 14
		Air is in fuel.	→Please contact your CANYCOM representative.	
		Engine fouled.	→Wait a while and try starting again.	
		Insufficient or wrong oil.	→Fill or change oil.	Page 38
		Dirty or damaged spark plug.	→Clean or replace spark plug.	Page 41
		Contamination in fuel system.	→Please contact your CANYCOM representative.	
		Other (other than the above).	→Please contact your CANYCOM representative.	

Area	Malfunction	Possible Cause	Corrective Measure	Ref.
Engine	Engine stalls.	Out of fuel.	→Fill fuel.	Page 14
		Cold engine.	→Warm up engine.	
		Other (other than the above).	→Please contact your CANYCOM representative.	
	Engine stops abruptly.	Out of fuel	→Fill fuel.	Page 14
		Piston seizure due to insufficient or bad oil.	→Please contact your CANYCOM representative.	
		Other (other than the above).	→Please contact your CANYCOM representative.	
	Engine does not stop	Electrical malfunction	→Please contact your CANYCOM representative.	
		Other (other than the above).	→Please contact your CANYCOM representative.	
	Idling is not stable.	Insufficient intake air (clogged air cleaner).	→Clean or replace air cleaner.	Page 40
		Other (other than the above).	→Please contact your CANYCOM representative.	
	Poor power or acceleration	Bad fuel	→Change fuel.	
		Wrong oil (improper viscosity)	→Change to suitable oil.	Page 38
		Accelerator (throttle) is not properly adjusted.	→Please contact your CANYCOM representative.	
		Insufficient intake air (clogged air cleaner).	→Clean or replace air cleaner.	Page 40
		Excessive load	→Reduce load.	
Loose drive belt.		→Adjust	Page 47	
Other (other than the above).		→Please contact your CANYCOM representative.		
Irregular noise or vibration from or around the engine		→Please contact your CANYCOM representative.		

Area	Malfunction	Possible Cause	Corrective Measure	Ref.	
Engine	Excessive oil consumption		→Please contact your CANYCOM representative.		
	Engine overheats	Insufficient amount of engine oil.	→Fill oil.	Page 38	
		Cooling fan is clogged or blocked.	→Clean.		
		Other (other than the above).	→Please contact your CANYCOM representative.		
	Excessive fuel consumption	Clogged air cleaner.	→Clean or replace air cleaner.	Page 40	
		Other (other than the above).	→Please contact your CANYCOM representative.		
	Black smoke comes out of exhaust	Bad fuel.	→Change fuel.		
		Clogged air cleaner.	→Clean or replace air cleaner.	Page 40	
		Choke is not fully open.	→Open the choke fully.		
		Other (other than the above).	→Please contact your CANYCOM representative.		
	White or blue smoke comes out of exhaust	Engine oil level is too high.	→Adjust the oil level.		
		Other (other than the above).	→Please contact your CANYCOM representative.		
	Drive Train	Machine does not move (forward, backward, turning) when the control stick is in the corresponding position.	Clutch is not engaged	→Engage the clutch.	
			Parking brake is applied	→Release parking brake.	Page 22
Excessive load			→Reduce load.		
Insufficient or deteriorated HST fluid.			→Add or change fluid.	Page 43	
Other (other than the above).			→Please contact your CANYCOM representative.		
Irregular noise or heat is observed at or around the track.			→Please contact your CANYCOM representative.		

6

Troubleshooting

Area	Malfunction	Possible Cause	Corrective Measure	Ref.
Brake	Brake does not work well.	Not properly adjusted.	→Adjust.	Page 48
		Brake is wet with water.	→Apply brake a few times to dry.	
		Other (other than the above).	→Please contact your CANYCOM representative.	
Track	Track does not move smoothly.	Not properly adjusted.	→Adjust.	Page 42
		Other (other than the above).	→Please contact your CANYCOM representative.	
Safety Devices	Lamp does not light.	Blown bulb.	→Replace.	
		Blown fuse.	→Replace.	Page 57
		Other (other than the above).	→Please contact your CANYCOM representative.	
	Horn does not work.	Blown fuse.	→Replace.	Page 58
		Other (other than the above).	→Please contact your CANYCOM representative.	
Hydraulic (Dump and Turn) system	Dump or turn does not work.	Insufficient or deteriorated hydraulic fluid.	→Add or change fluid.	Page 43
		Loose hydraulics belt.	→Adjust.	Page 54
		Other (other than the above).	→Please contact your CANYCOM representative.	

Hauling

⚠️ WARNING!

- Park transporter (truck) on a level ground. Always use chocks to secure the wheels.
- Do not allow bystandars to come close to machine or transporter when loading or unloading machine.
- Use only the loading ramps with sufficient strength (to withstand the combined weight of machine and operator), width (more than 1.2 times the width of track), and length (more than 3 times the height of the loading deck of transporter), and have anti-slip ramp surfaces.
- Secure the hooks of loading ramps firmly and flush with loading deck.
- Never ride machine when loading to or unloading from transporter. Fold step and drive in the walk-behind mode.
- Move slowly forward when loading onto, and move slowly backward when unloading off of the transporter. Pay special care when going over the joint between loading deck and ramps; machine may tip.
- Do not turn on loading ramps. Machine may fall.
- Tie down machine securely. Make sure machine does not move around.

Loading and Unloading

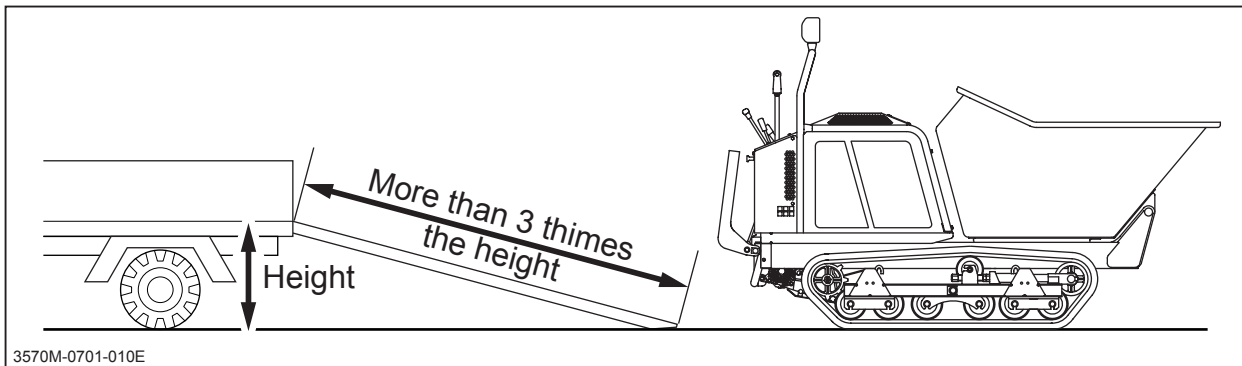

Loading to the Transporter

1. Park transporter. Secure the wheels with chocks.
2. Place loading ramps. Secure the hooks of ramps firmly and flush with loading deck.
3. Fold step. (Page 28)
4. In the walk-behind mode, drive machine slowly backward onto loading deck.
5. Park machine according to the instructions in "**Parking**" (Page 22).
6. Secure machine onto loading deck with rope or tie-down belts.

Unloading from the Transporter

1. Park transporter. Secure the wheels with chocks.
2. Undo rope or tie-downs that secure machine.
3. Place loading ramps. Secure the hooks of ramps firmly and flush with loading deck.
4. In the walk-behind mode, drive machine slowly forward from loading deck to the ground.

Hoisting

⚠ WARNING!

- Use hoisting (slinging) attachments (wire ropes, chains, etc.) of sufficient strength. Always use the ones of the same length when more than one is used.

⚠ CAUTION!

- Always unload machine before hoisting.

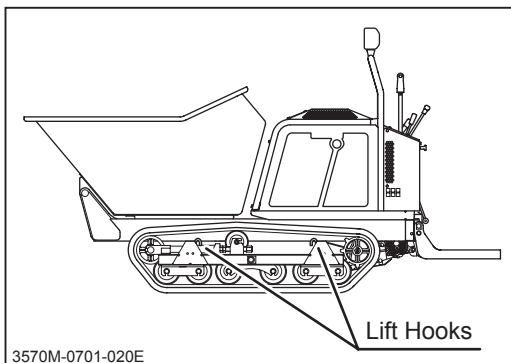

1. Attach hoisting wire ropes to the 4 lift hooks located on the corners of machine. Hoist the center of the ropes.

NOISE LEVEL

Model	Engine		LwA
Type	Type	Speed rpm	
SC75	Robin EH65DS	2440rpm	101 dB (A)

NOISE LEVEL evaluated based on factory standard.

VIBRATION

Model	Engine Rated revolution	Vibration		
		Control Stick	Handrail	Step
SC75	1800	1.10 m/s	3.50 m/s	1.70 m/s
	3400	1.10 m/s	3.60 m/s	3.0 m/s

VIBRATION evaluated based on factory standard.