



OPERATING MANUAL (ANSI/CSA)

ARTICULATING BOOMS

MODELS **SJ46AJ**

169510AD-A November 2015

SKYJACKTM

This manual is based on Serial Number(s):

SJ 46AJ 95 000 853 & Above

Please refer to the website (www.skyjack.com) for older Serial Numbers.

Skyjack Service Center

3451 Swenson Ave. St. Charles,
Illinois, 60174 USA
Phone: 630-262-0005
Toll Free: 1-800-275-9522
Fax: 630-262-0006
Email: service@skyjack.com

Parts (North America)

Toll Free: 1-800-965-4626
Toll Free Fax: 1-888-782-4825
E-mail: parts@skyjack.com

Skyjack Australia Pty Ltd.

4 Coates Place
Wetherill Park
New South Wales 2164
Australia
Tel: +61 (0) 28786 3200
Fax: +61(0) 28786 3222

Parts & Service (Europe)

Unit 1 Maes Y Clawdd
Maesbury Road Industrial Estate
Oswestry, Shropshire SY10 8NN UK
Phone: +44-1691-676-235
Fax: +44-1691-676-238
E-mail: info@skyjackeurope.co.uk

Skyjack Brasil

Alameda Júpiter, 710
Loteamento American Park Empresarial
Indaiatuba, SP, Brasil 13347-653
Tel: +55 19 3936 0132

The Safety Alert Symbol identifies important safety messages on aerial platform, safety signs in manuals or elsewhere. When you see this symbol, be alert to the possibility of personal injury or death. Follow the instructions in the safety message.



This Safety Alert Symbol means attention!

Become alert! Your safety is involved.



DANGER

DANGER indicates an imminently hazardous situation which, if not avoided, will result in death or serious injury.



WARNING

WARNING indicates a potentially hazardous situation which, if not avoided, could result in death or serious injury.



CAUTION

CAUTION indicates a potentially hazardous situation which, if not avoided, may result in minor or moderate injury. It may also be used to alert against unsafe practices.

IMPORTANT

IMPORTANT indicates a procedure essential for safe operation and which, if not followed, may result in a malfunction or damage to the aerial platform.

Table of Contents

Section 1 - About Your Aerial Platform	5
Read and Heed	5
Safety Rules.....	6
Section 2 - Familiarization	13
2.1 Familiarization of Articulated Boom Series	13
2.2 Component Identification	14
2.3 Visual & Daily Maintenance Inspections	20
2.4 Function Tests.....	28
2.5 Winching and Towing Procedure	40
2.6 Emergency Lowering Procedures.....	42
Section 3 - Operation	43
3.1 General	43
3.2 Major Components	44
3.3 Major Assemblies	45
3.4 Serial Number Nameplate	45
3.5 Component Identification	46
3.6 Component Identification (Optional Equipment/Attachments).....	47
3.7 Operator's Responsibility	49
3.8 Start Operation	50
3.9 Refueling Procedure.....	55
3.10 Loading/Unloading	57
3.11 Chassis Tilt.....	59
3.12 Technical Diagrams	60
Section 4 - Tables.....	63
Table 4.1 Standard and Optional Features	63
Table 4.2a Specifications and Features	64
Table 4.2b Specifications and Features	65
Table 4.3 Owner's Annual Inspection Record.....	66
Table 4.4 Tire/Wheel Specifications	67
Table 4.5 Maximum Platform Capacities.....	67
Table 4.6 Floor Loading Pressure	68
Table 4.7 Maintenance and Inspection Schedule.....	69
Table 4.8 Operator's Checklist.....	70
Section 5 - Labels.....	71

SKYJACK is continuously improving and expanding product features on its equipment, therefore, specifications and dimensions are subject to change without notice.

Aerial Platform Definition

A mobile device that has an adjustable position platform supported from ground level by a structure.

Purpose of Equipment

The SKYJACK Articulating Boom Series (Model SJ 46AJ) aerial platform is designed to transport and raise personnel, tools and materials to overhead work areas.

Use of Equipment

The aerial platform is a highly maneuverable, mobile work station. Work platform elevation and elevated driving must only be done on a firm, level surface. It can be driven over uneven terrain only when the platform is fully lowered.

Manual

The operating manual is considered a fundamental part of the aerial platform. It is a very important way to communicate necessary safety information to users and operators. A complete and legible copy of this manual must be kept in the provided weather-resistant storage compartment on the aerial platform at all times.

Operator

The operator must read and completely understand both this operating manual and the safety panel label located on the platform and all other warnings in this manual and on the aerial platform. Compare the labels on the aerial platform with the labels found within this manual. If any labels are damaged or missing, replace them immediately.

Service Policy and Warranty

SKYJACK warrants each new articulating series work platform to be free of defective parts and workmanship for the first 24 months. Any defective part will be replaced or repaired by your local SKYJACK dealer at no charge for parts or labor. Contact the SKYJACK Service Department for warranty statement extensions or exclusions.

Optional Accessories

The SKYJACK aerial platform is designed to accept a variety of optional accessories. These are listed under "Standard and Optional Features" in [Table 4.1](#). Operating instructions for these options (if equipped) are located in [Section 3](#) of this manual.

For non-standard components or systems, contact the SKYJACK Service Department at:

☎ : 800 275-9522

📠 : 630 262-0006

Include the model and serial number for each applicable aerial platform.

Scope of this Manual

- a. **This manual applies** to the ANSI/SIA and CSA versions of the Articulating Boom aerial platform models listed on [Table 4.1](#).
 - **Equipment identified** with "ANSI" meets the ANSI/SIA A92.5-2006 standard.
 - **Equipment identified** with "CSA" meets the CSA B354.4-02 standard.
- b. **CSA (Canada)**

Operators are required to conform to national, territorial/provincial and local health and safety regulations applicable to the operation of this aerial platform.
- c. **ANSI/SIA (United States)**

Operators are required by the current ANSI/SIA A92.5 standards to read and understand their responsibilities in the manual of responsibilities before they use or operate this aerial platform.

**WARNING**

Failure to comply with your required responsibilities in the use and operation of the aerial platform could result in death or serious injury!

Operator Safety Reminders

A study conducted by St. Paul Travelers showed that most accidents are caused by the failure of the operator to follow simple and fundamental safety rules and precautions.

You, as a careful operator, are the best insurance against an accident. Therefore, proper usage of this aerial platform is mandatory. The following pages of this manual should be read and understood completely before operating the aerial platform.

Common sense dictates the use of protective clothing when working on or near machinery. Use appropriate safety devices to protect your eyes, ears, hands, feet and body.

Any modifications from the original design are strictly forbidden without written permission from SKYJACK.

Electrocution Hazard

This aerial platform is not electrically insulated. Maintain a Minimum Safe Approach Distance (MSAD) from energized power lines and parts as listed below. The operator must allow for the platform to sway, rock or sag. This aerial platform does not provide protection from contact with or proximity to an electrically charged conductor.

Per ANSI A92.5-2006 8.10(7)

“The operator shall perform only the work for which he or she is qualified, in compliance with all applicable safety related work practices intended to prevent electric shock covered by the Code of Federal Regulations (CFR) 1910.333. The operator’s level of competence shall be established only by persons qualified to do so. Operators shall maintain the appropriate minimum approach distance (**MAD**) from energized power lines and parts covered by CFR 1910.333 (c).”

Unqualified persons must maintain a minimum approach distance of 10 feet from any energized power line up to 50 kV. Energized power lines over 50 kV require a greater minimum approach distance to be maintained. Refer to CFR 1910.333.

As per CSA B354.4-02

“The operator shall maintain the minimum safe approach distance (**MSAD**) from energized conductors at all times in accordance with the authority having jurisdiction.”

Refer to CFR 1910.333 or the authority having jurisdiction.

**DO NOT USE THE AERIAL PLATFORM AS A GROUND FOR WELDING.
DO NOT OPERATE THE AERIAL PLATFORM DURING LIGHTNING OR STORMS.
DO NOT OPERATE THE AERIAL PLATFORM NEAR POWER LINES. MAINTAIN A MINIMUM SAFE APPROACH DISTANCE (MSAD) FROM ENERGIZED POWER LINES.**

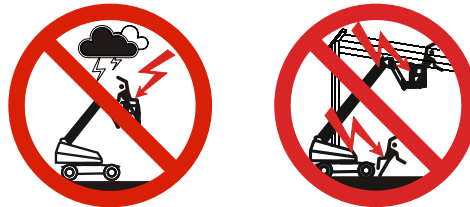

DANGER

Avoid Power Lines

Minimum Safe Approach Distance

ANSI/SIA A92.6-2006 & CSA B354.2-01 Requirements

Voltage Range (Phase to Phase)	Minimum Safe Approach Distance (Feet)
0 to 300V	Avoid Contact
Over 300V to 50KV	10
Over 50KV to 200KV	15
Over 200KV to 350KV	20
Over 350KV to 500KV	25
Over 500KV to 750KV	35
Over 750KV to 1000KV	45

FAILURE TO AVOID THIS HAZARD WILL RESULT IN DEATH OR SERIOUS INJURY!

60023AD-ANSI

Safety Precautions

Know and understand the safety precautions before going on to next section.



WARNING

Failure to heed the following safety precautions could result in tip over, falling, crushing, or other hazards leading to death or serious injury.

- **KNOW** all national, state or territorial/provincial and local rules which apply to your aerial platform and jobsite.
- **TURN** main power disconnect switch “O” off when leaving the aerial platform unattended. Remove the key to prevent unauthorized use of the aerial platform.
- **WEAR** all the protective clothing and personal safety devices issued to you or called for by job conditions.
- **DO NOT** wear loose clothing, dangling neckties, scarves, rings, wristwatches or other jewelry while operating this aerial platform .



- **AVOID** entanglement with ropes, cords or hoses.



- **AVOID** falling. Stay within the boundaries of the guardrails.



- **DO NOT** raise the aerial platform or operate elevated in windy or gusty conditions that exceed the limits specified in [Section 4, Table 4.5](#).



- **DO NOT** increase the lateral surface area of the platform. Increasing the area exposed to the wind will decrease aerial platform stability. Avoid tenting.



- **DO NOT** elevate the aerial platform if it is not on a firm, level surface.

- **DO NOT** drive elevated near depressions or holes of any type, loading docks, debris, drop-offs and surfaces that may affect the stability of the aerial platform.



- **DO NOT** elevate or drive elevated on a slope. Elevated driving must be done on a firm, level surface.



- **If operation in areas with holes or drop-offs is absolutely necessary**, elevated driving shall not be allowed. Position the aerial platform horizontally only with the platform fully lowered. After ensuring that all 4 wheels or outriggers (if equipped) have contact with a firm, level surface, the aerial platform can be elevated. After elevation, the drive function must not be activated.



- **DO NOT** drive elevated on a soft or uneven surface.



- **DO NOT** ascend or descend a grade steeper than 45% (2WD & 4WD). Boom elevated driving must only be done on firm, level surfaces.



Safety Precautions (Continued)

Know and understand the safety precautions before going on to next section.

- **DO NOT** operate an aerial platform that has ladders, scaffolding or other devices mounted on it to increase its size or work height. It is prohibited.

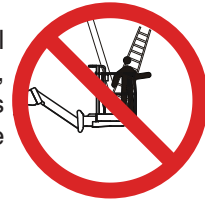

- **DO NOT** exert horizontal (manual) force on aerial platform that exceeds the limits specified in [Table 4.5](#).



- **DO NOT** use the aerial platform as a crane. It is prohibited.



- **DO NOT** climb on boom arm assembly. It is prohibited.



- **DO NOT** sit, stand or climb on the guardrails. It is prohibited.



- **AVOID** overhead obstructions. Be aware of overhead obstructions or other possible hazards around aerial platform when lifting or driving.



- **AVOID** crushing hazards. Be aware of crushing hazards when lifting or driving. Keep all body parts inside the aerial platform.



- **BE AWARE** of blind spots when operating the aerial platform.



- **ENSURE** that there are no personnel or obstructions in the path of travel, including blind spots.

- **DO NOT** lower the platform unless the area below is clear of personnel and obstructions.

- **DO NOT** use boom to push, pull other objects or to lift the chassis.



- **DO NOT** raise the aerial platform while it is on a truck, forklift or other device or vehicle.



- **STUNT** driving and horseplay are prohibited.

- **ENSURE ALL** tires are in good condition and lug nuts are properly tightened.

- **DO NOT** use with improperly inflated/damaged tires or wheels. Refer to [Section 2: Wheel/Tire Assembly](#).



- **DO NOT** alter or disable limit switches or other safety devices.

- **DO NOT** use the aerial platform without guardrails, locking pins and the entry gate in place.

Safety Precautions (Continued)

Know and understand the safety precautions before going on to next section.

- **DO NOT** exceed the rated capacity of the aerial platform.



- **DO NOT** position the aerial platform against another object to steady the platform.

- **DO NOT** distribute load unevenly.



- **DO NOT** place materials on the guardrails or materials that exceed the confines of the guardrails unless approved by Skyjack.

- **DO NOT** use under influence of alcohol or drugs.



- **DO NOT** operate if aerial platform is not working properly or if any parts are damaged or worn.



- **DO NOT** attempt to free a snagged platform with lower controls until personnel are removed from the platform.

- **DO NOT** leave aerial platform unattended with key in key switch.



Safety Precautions

Know and understand the safety precautions before going on to next section.

Fall Protection

All occupants of this aerial platform must wear personal fall protection equipment.

As per the ANSI A92.5-2006 standard, "Principal fall protection is provided by the guardrail system. The user shall direct and monitor the operator to ensure that all components of the guardrail system are in place. The user shall direct and monitor the occupants of the work platform to ensure that they wear a personal fall arrest system to protect against the potential effects of ejection or a fall restraint system to prevent a free fall."

Fall restraint and fall arrest systems are defined within the ANSI A92.5 Manual of Responsibilities shipped with this aerial platform.

Skyjack recommends the use of a fall restraint system to keep an occupant within the confines of the platform, and thus not expose the occupant to any fall hazard requiring a fall arrest.

CSA B354.4-02 requires the use of a fall arrest system, therefore Canadian users must use personal fall arrest protection as opposed to fall restraint.

All personal fall protection equipment must comply with applicable governmental regulations and must be inspected and used in accordance with the manufacturer's recommendations.

All personal fall protection equipment must be attached only to approved anchorage points within the platform of the aerial platform.



WARNING

Entering and exiting the aerial platform should only be done using the three points of contact.

- **Use only equipped access openings.**
- **Enter and exit only when the aerial platform is in the fully retracted position.**

- Do use three points of contact to enter and exit the platform. Enter and exit the platform from the ground only. Face the aerial platform when entering or exiting the platform.
- Three points of contact means that two hands and one foot or one hand and two feet are in contact with the aerial platform or the ground at all times during entering and exiting.



WARNING

An operator should not use any aerial platform that:

- **does not appear to be working properly.**
- **has been damaged or appears to have worn or missing parts.**
- **has alterations or modifications not approved by the manufacturer.**
- **has safety devices which have been altered or disabled.**
- **has been tagged or locked out for non-use or repair.**

Failure to avoid these hazards could result in death or serious injury.

Jobsite Inspection

- Do not use in hazardous locations (see NFPA 505).
- Perform a thorough jobsite inspection prior to operating the aerial platform, to identify potential hazards in your work area.
- Be aware of moving equipment in the area. Take appropriate actions to avoid collision.

2.1 Familiarization of Articulated Boom Series



WARNING

Aerial platform Familiarization should be given only to individuals who are QUALIFIED/COMPETENT and TRAINED to operate an aerial platform.

Do not operate this aerial platform without proper authorization and training. Failure to avoid this hazard could result in death or serious injury.

It is the responsibility of the operator to read, completely understand and follow all instructions and warnings contained in this operating manual and on the aerial platform.

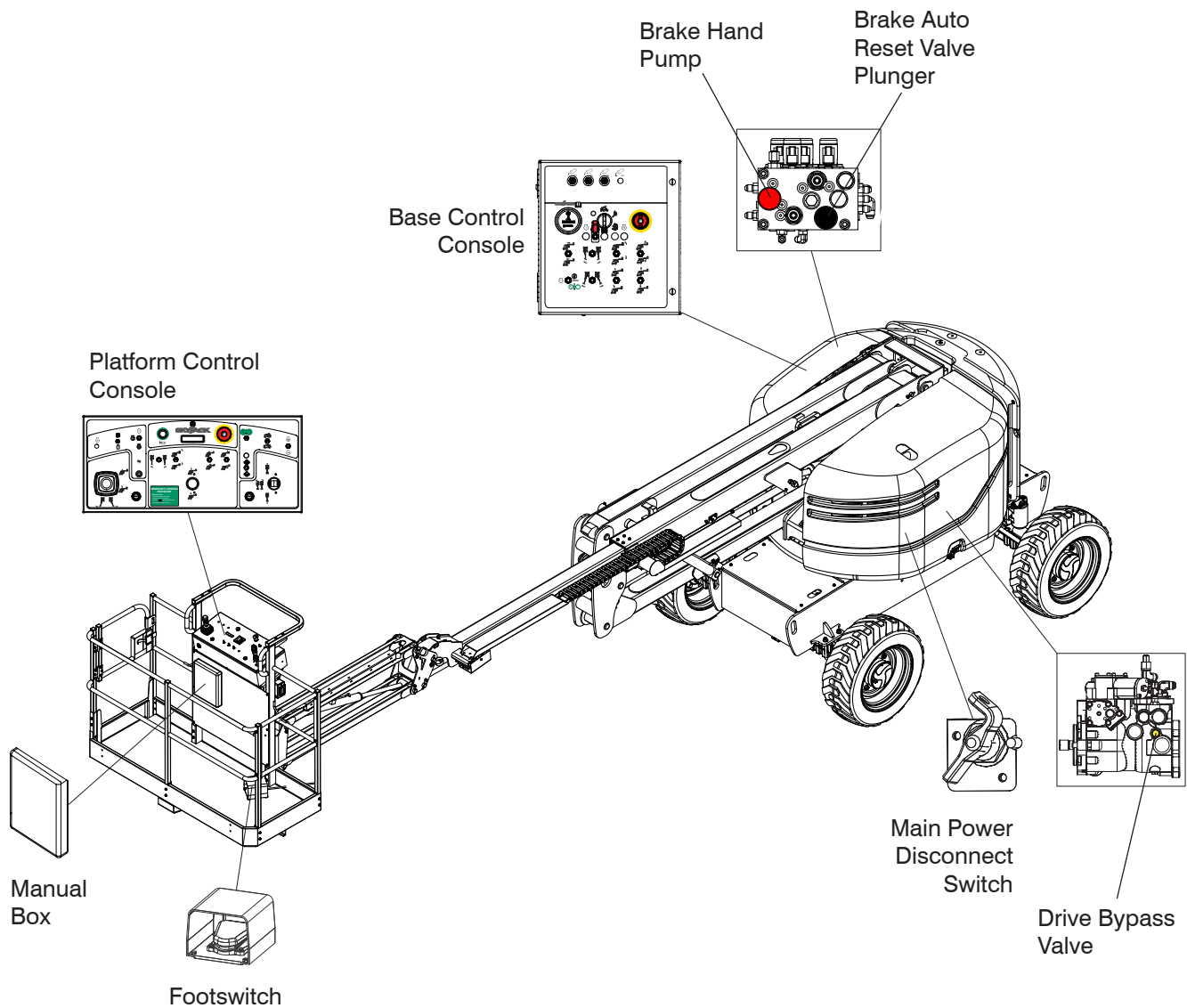

FAMILIARIZATION

2.2 Component Identification

The following descriptions are for identification, explanation and locating purposes only.

2.2-1 Main Power Disconnect Switch

This main power disconnect switch is located in the engine compartment near the battery.

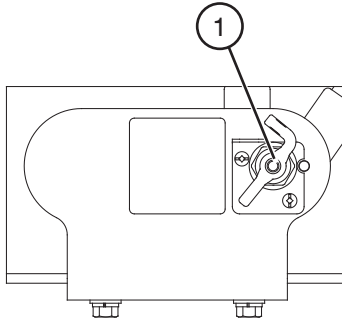

Figure 2-1. Main Power Disconnect Switch

1. **Main Power Disconnect Switch** - This switch, when in “○” off position, disconnects power to all circuits. Switch must be in “I” on position to operate any circuit. Turn switch “○” off when transporting aerial platform.

2.2-2 Tilt Sensor

The tilt sensor is located inside the base control console. It is designed to prevent driving when aerial platform is on a slope greater than a predetermined limit.



WARNING

If aerial platform becomes tilted causing alarm to sound, the platform must be fully lowered immediately. Ensure that aerial platform is on a firm level surface before operating the aerial platform. Refer to Section 3.11 for instructions regarding recovery from an inclined position.

2.2-3 Drive Bypass Valve

This valve is located on the inboard side of the drive pump and can be identified with a yellow paint mark on it.

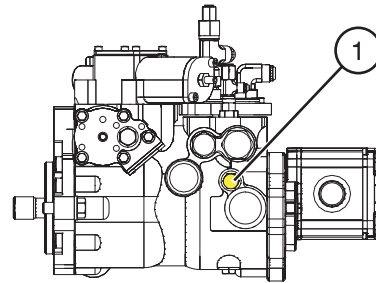

Figure 2-2. Drive Bypass Valve

1. **Drive Bypass Valve with Override Stems** - This valve, when loosened two revolutions counterclockwise, is used to override drive relief valves so that the aerial platform can be loaded or unloaded from a trailer using a winch line.

2.2-4 Brake System

The brake system is located in the control compartment. The brakes must be manually disengaged before pushing, winching or towing. Refer to [Section 2.5-1](#) for procedure on how to release brakes manually. The system contains the following controls:

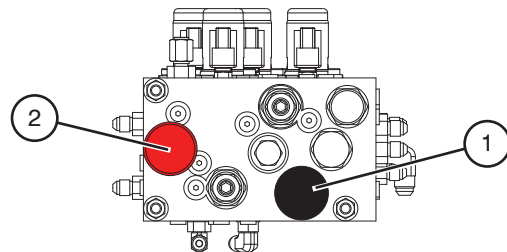

Figure 2-3. Brake System

1. Brake Auto Reset Valve Plunger
2. Brake Hand Pump

2.2-5 Differential Lock Switch

This switch is located on the platform control console. The differential locking system provides more traction by providing equal drive to each wheel regardless of traction. Differential locks are used to prevent from getting stuck when driving on loose, muddy, or rocky terrain. Refer to [Section 2.4-3](#) for instruction regarding testing differential lock switch.



WARNING

Before engaging differential lock, ensure drive/steer controller is in neutral position.

2.2-6 Footswitch

The footswitch is located on the floor of the platform. When depressed and held, it enables controls on platform control console.

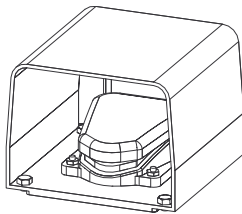

Figure 2-4. Footswitch

NOTE

The footswitch is equipped with a 15-second anti-tiedown feature that deactivates footswitch when operator depresses it for 15 seconds without activating any function.

2.2-7 Base Control Console

This control console is located in the panel mounted in the control compartment.

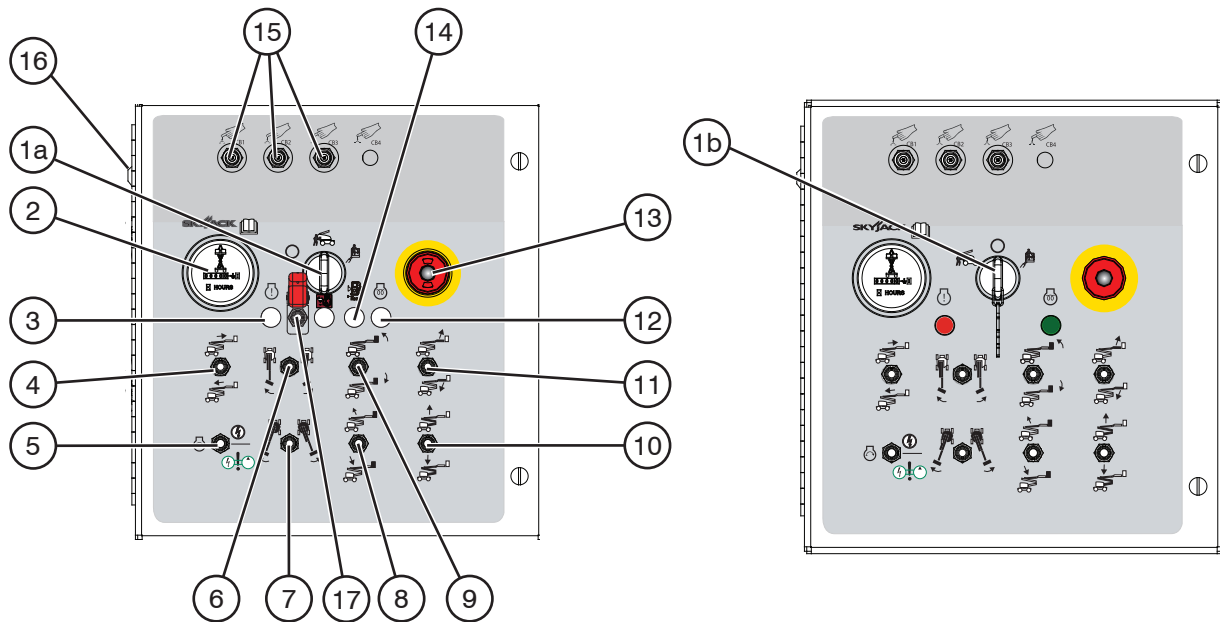

Figure 2-5. Base Control Console

- 1a. **Off/Base/Platform Key Switch** - This three-way selector switch allows operator to “○” turn off power to aerial platform or to activate either “” base or “” platform control console.
- b. **Base/Off/Platform Key Switch** - This three-way selector switch allows operator to “○” turn off power to aerial platform or to activate either “” base or “” platform control console.
2. **Hourmeter** - This gauge records accumulated operating time of engine.
3. **Engine Fault** - This light indicates failure in engine control system.
4. **Fly Boom Extend/Retract Switch** - This switch controls “” extension or “” retraction of fly boom.
5. **Start/Function Enable/Emergency Power Switch** - This momentary switch, when held in “” start position, starts engine. When held in “” function enable position, allows base control functions to operate. With engine off, and when held in “” emergency power unit position, allows base control functions to operate using emergency power unit.
6. **Platform Rotation Switch** - This switch controls “” left or “” right rotation of platform.
7. **Turret Rotation Switch** - This switch controls “” left or “” right rotation of turret.
8. **Main Boom Raise/Lower Switch** - This switch controls “” raising or “” lowering of main boom.
9. **Platform Leveling Override Switch** - This switch overrides automatic leveling of platform and controls “” tilting up or “” tilting down of platform.

2.2-7 Base Control Console (Continued)

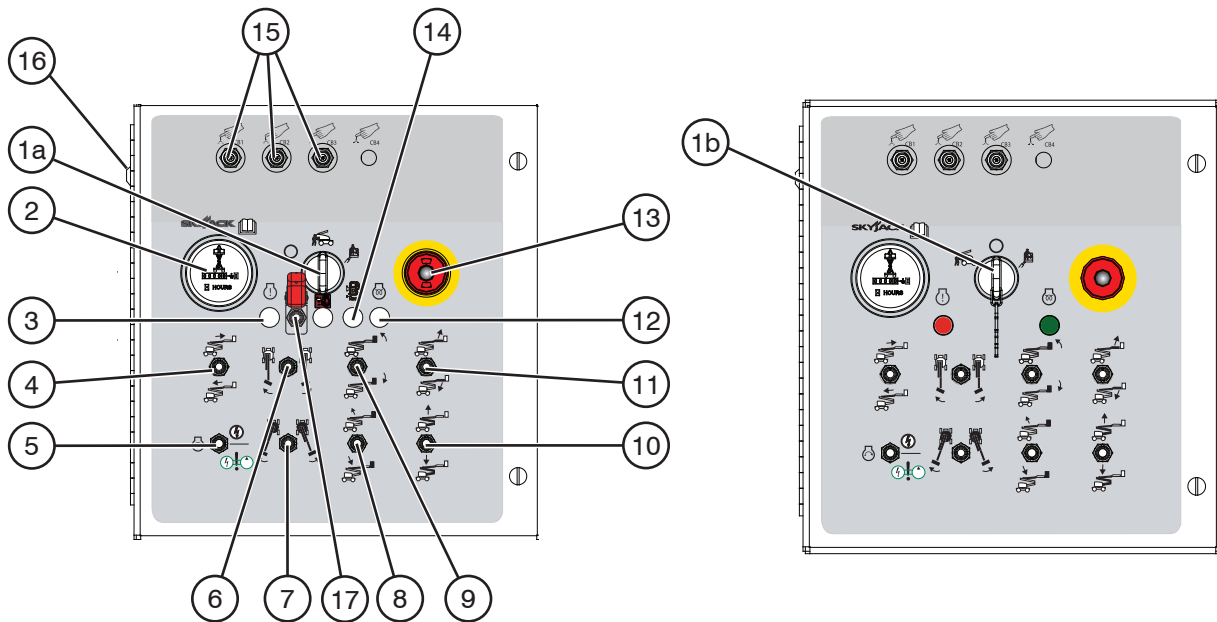

Figure 2-5. Base Control Console

- 10. Riser Raise/Lower Switch** - This switch controls “ ” raising or “ ” lowering of riser.
- 11. Jib Up/Down Switch** - This switch controls “ ” up or “ ” down movement of jib.
- 12. Glow Plug (Diesel)** - This light illuminates until glow plugs have completed their timed cycle. When the lamp goes out, the engine is ready to be started..
- 13. Emergency Stop Button** - This red “mushroom-head” “ ” pushbutton disconnects power to control circuit and shuts engine off.
- 14. Water In Fuel Light (If Equipped)** - This light indicates water separator is full. Open drain to release water. Engine damage could occur if ignored for excessive length of time.
- 15. Circuit Breakers** - In the event of a power overload or positive circuit grounding, the circuit breaker pops out. Push breaker back in to reset.
- 16. Engine Diagnosis Switch (If Equipped)** - When held in either direction, this switch “ ” enables an error blink code for engine control unit (ECU).
- 17. Positive Air Shutoff Switch (If Equipped)** - This switch allows the operator to shut off the air supply to the engine if the engine continues running after the main power is shut down.

2.2-8 Platform Control Console

This control console is mounted at front guardrail of the platform. It has the following controls:

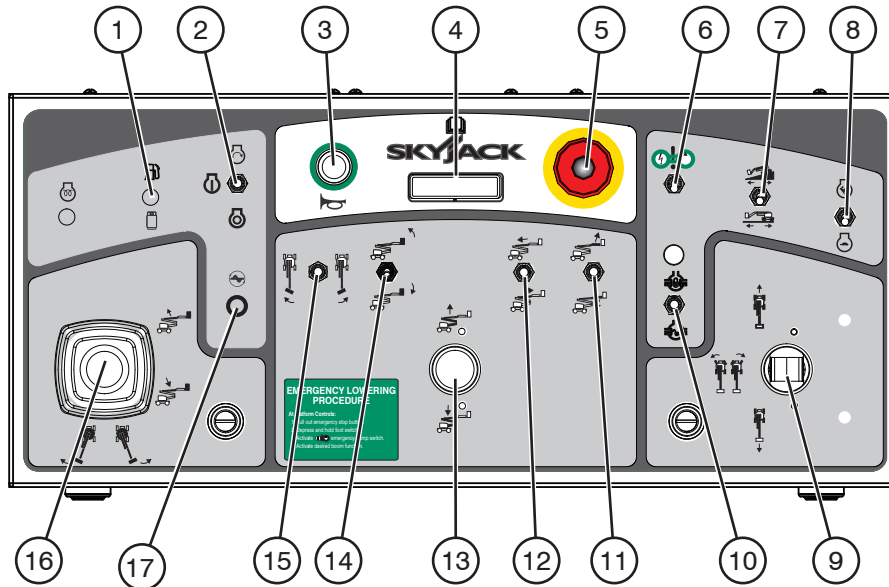
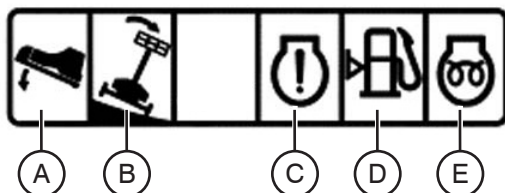

Figure 2-6. Platform Control Console

- 1. **Dual Fuel Switch (If Equipped)** - This switch selects between “” gasoline or “” liquid propane gas.
- 2. **Engine Start/On/Off Switch** - This switch, when held momentarily in “” start position, starts engine. Once started, the switch returns to “” on position. When in “” off position, it turns engine off.
- 3. **Horn Pushbutton** - This “” pushbutton sounds an automotive-type horn.
- 4. **Status Indicator Pilot Lights** - These lights indicate operational status and errors in any function in the controls/engine.

- B. **Chassis Tilt** - This light illuminates when the aerial platform chassis is at an inclination that activates the tilt sensor. At this inclination, an audible alarm will sound at the platform. Refer to [Section 3.11](#) for instructions regarding recovery from an inclined position.
- C. **Engine** - This light indicates failure in engine control system.
- D. **Fuel** - This light indicates low fuel level.
- E. **Glow Plug (Diesel)** - This light illuminates until glow plugs have completed their timed cycle. When the lamp goes out, the engine is ready to be started.



- A. **Footswitch** - This light illuminates when footswitch is depressed. A 15-second anti-tiedown feature deactivates footswitch when operator depresses it for 15 seconds without activating any function.

- 5. **Emergency Stop Button** - This red “mushroom-head” “” pushbutton disconnects power to control circuit and shuts engine off.
- 6. **Emergency Power Unit** - This switch “” enables emergency power unit.
- 7. **Torque Switch** - This switch selects “” low or “” high torque.
- 8. **Low/High Throttle Switch** - This switch allows selection between “” low and “” high engine throttle speeds.

2.2-8 Platform Control Console (Continued)

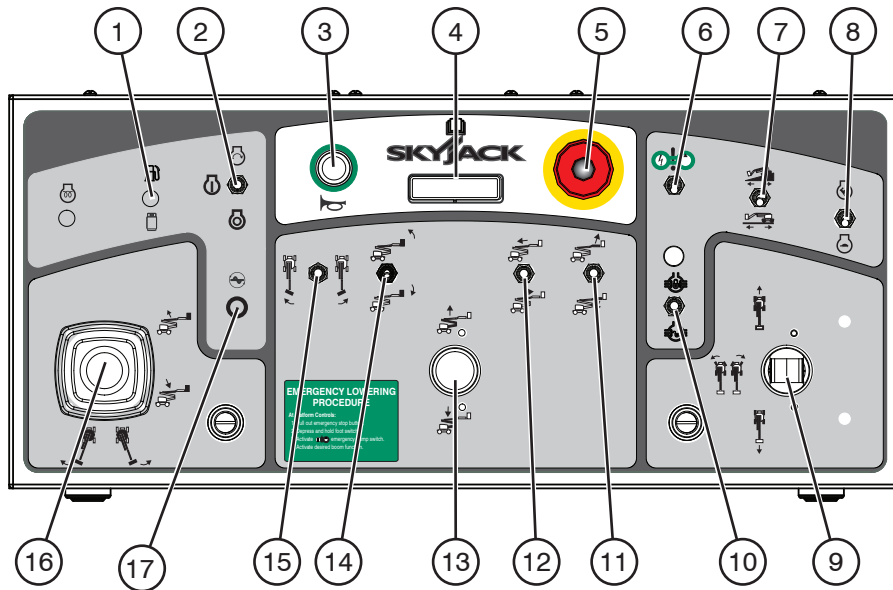

Figure 2-6. Platform Control Console

9. Drive/Steer Controller - This single-axis lever controls driving “” forward or “” backward. The rocker switch controls steering “” left or “” right. Internal springs return it to neutral when stick is released.

10. Differential Lock Switch - This momentary switch, when pushed forward and then released, engages “” differential lock and turns differential light on. When pulled backward and then released, disengages “” differential lock and turns differential light off.

11. Jib Up/Down Switch - This switch controls “” up or “” down movement of jib.

12. Fly Boom Extend/Retract Switch - This switch controls “” extension or “” retraction of fly boom.

13. Riser Raise/Lower Controller - This single-axis lever controls “” raising or “” lowering of riser.

14. Platform Leveling Override Switch - This switch overrides automatic leveling of platform and controls “” tilting up or “” tilting down of platform.

15. Platform Rotation Switch - This switch controls “” left or “” right rotation of platform.

16. Boom/Turret Controller - This dual-axis lever controls “” raising or “” lowering of main boom or rotating “” left or “” right of turret.

17. Generator On/Off Switch (If Equipped) - This switch turns the hydraulic generator “” on or “” off.

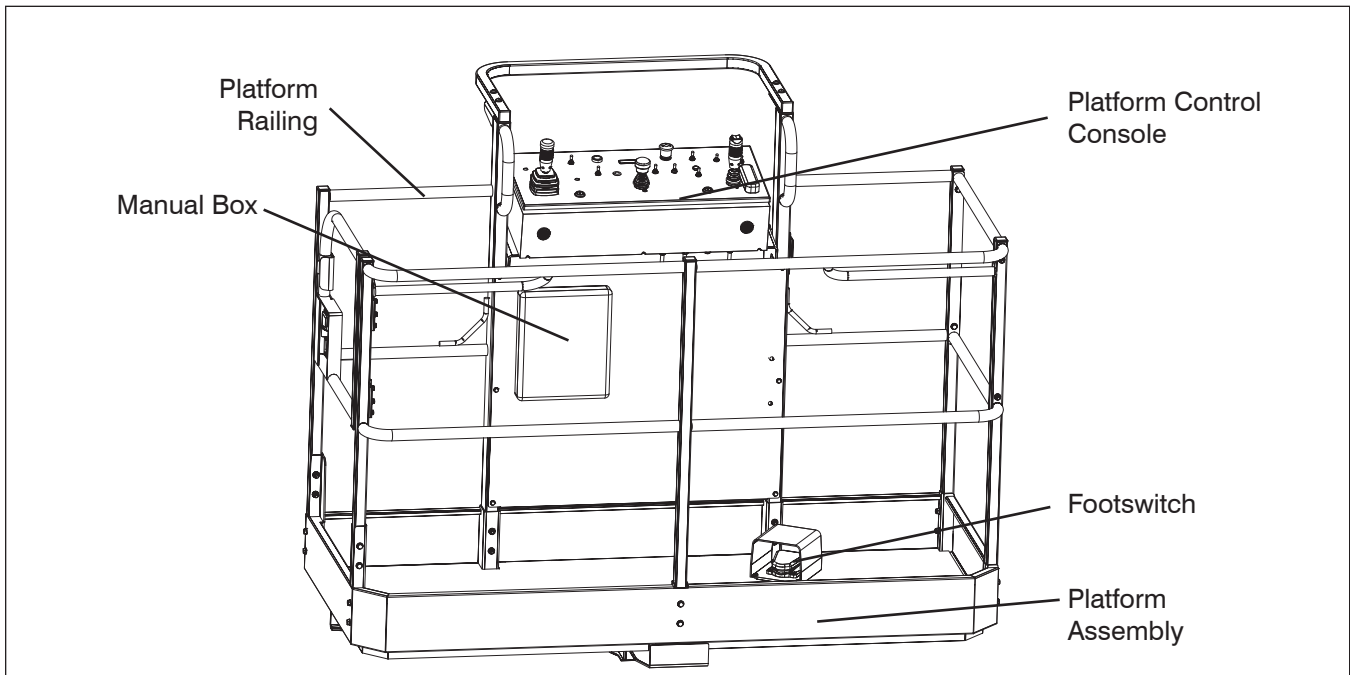

2.3 Visual & Daily Maintenance Inspections

Begin the visual and daily maintenance inspections by checking each item in sequence for the conditions listed in this section.



WARNING

To avoid injury, do not operate an aerial platform until all malfunctions have been corrected.



WARNING

To avoid possible injury, ensure aerial platform power is off during your visual and daily maintenance inspections.



CAUTION

Ensure aerial platform is on a firm, level surface.

NOTE

While doing visual and daily inspections in different areas, be aware to also inspect limit switches, electrical and hydraulic components.

2.3-1 Labels

Refer to [Section 5 - Labels](#) in this manual and determine that all labels are in place and are legible.

2.3-2 Electrical

Maintaining the electrical components is essential to good performance and service life of the aerial platform.

Inspect the following areas for chafed, corroded and loose wires:

- boom to platform cable harness
- engine compartment electrical panel
- engine wiring harness
- rotary manifold wiring

2.3-3 Limit Switches

Ensure limit switches are properly secured with no signs of visible damage and movement is not obstructed.

2.3-4 Hydraulic

Maintaining the hydraulic components is essential to good performance and service life of the aerial platform.

Perform a visual inspection around the following areas:

- hydraulic tank filter, fittings, hoses, emergency power unit and turret/base surface
- engine compartment fittings, hoses, main pump, filter and turret/base surface
- all hydraulic cylinders
- all hydraulic manifolds
- underside of the turret
- underside of the base
- ground area under the aerial platform

2.3-5 Engine Compartment

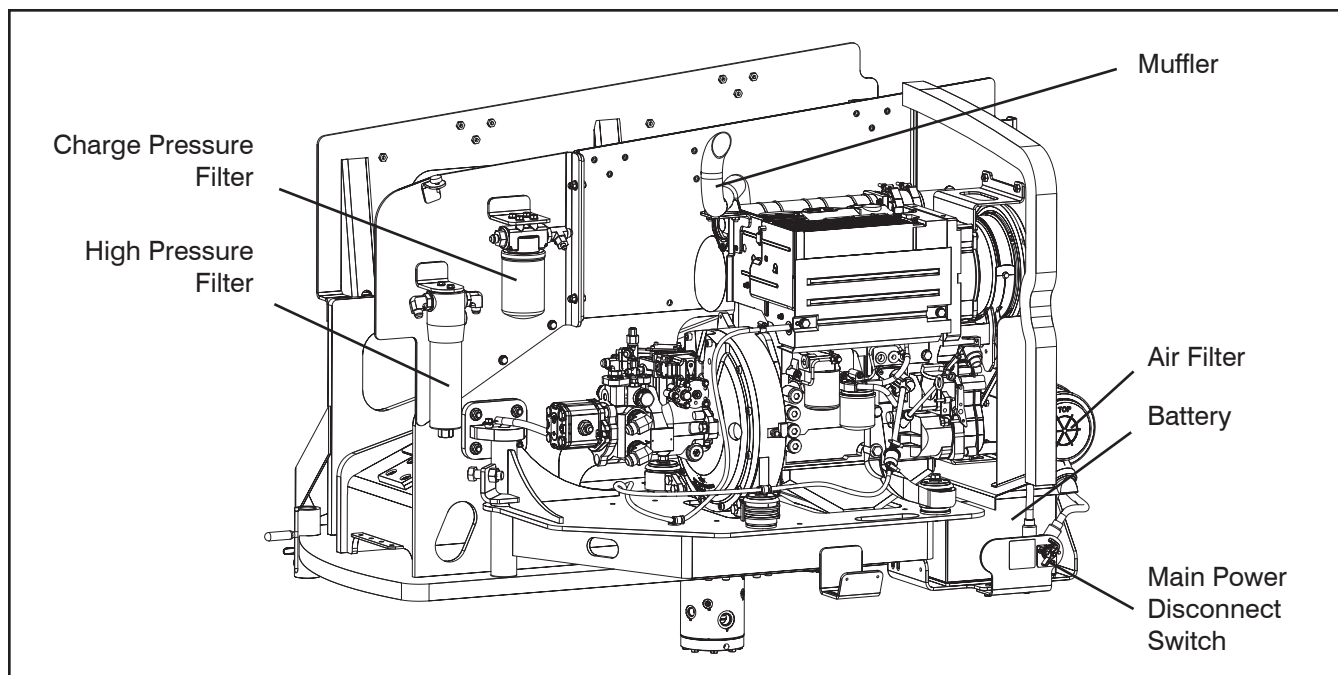

- Ensure all compartment latches are secure and in proper working order.
- **Main Power Disconnect Switch**
 - Turn main power disconnect switch to “○” off position.
 - Ensure there are no loose or missing parts and there is no visible damage.
 - Ensure all cables are secure and switch is in proper working condition.

- **Battery**
Proper battery condition is essential to good engine performance and operational safety. Improper fluid levels or damaged cables and connections can result in engine component damage and hazardous conditions.

1. Check battery cases for damage.
2. Clean battery terminals and cable ends thoroughly with a terminal cleaning tool or wire brush.
3. Ensure all battery connections are tight.
4. If applicable, check battery fluid level. If plates are not covered by at least 1/2” (13 mm) of solution, add distilled or demineralized water.
5. Replace battery if damaged or incapable of holding a lasting charge.



WARNING

Explosion hazard. Keep flames and sparks away. Do not smoke near batteries.



WARNING

Battery acid is extremely corrosive - Wear proper eye and facial protection as well as appropriate protective clothing. If contact occurs, immediately flush with cold water and seek medical attention.



WARNING

Use original or manufacturer-approved parts and components for the aerial platform.

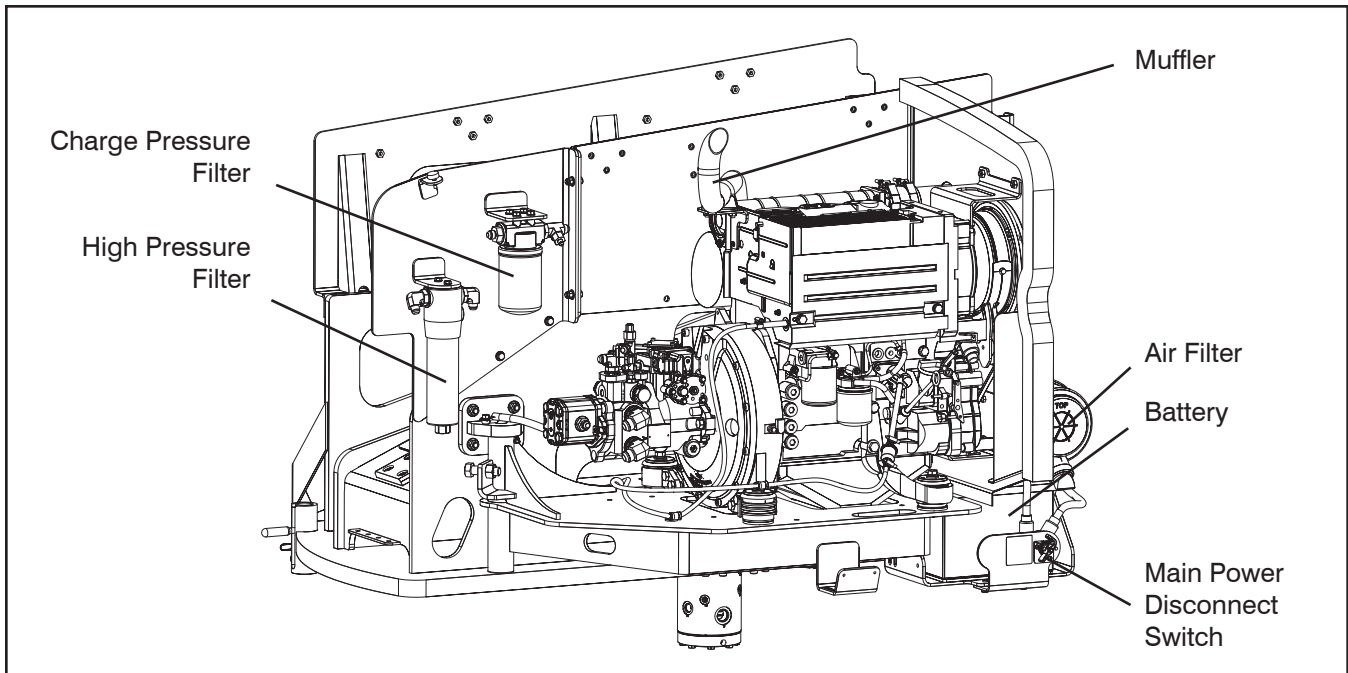

- **High Pressure Filter**
 - Ensure housing is secure and shows no visible damage or leakage.
- **Hydraulic Pumps**
 - Ensure there are no loose or missing parts and there is no visible damage.
 - Ensure all bolts are properly tightened.
 - Ensure all fittings and hoses are properly tightened and there is no evidence of hydraulic leakage.
- **Muffler and Exhaust**
 - Ensure muffler and exhaust system are properly secured, with no evidence of damage.
- **Engine Pivot Tray**
 - Ensure there are no loose or missing parts and no visible damage to the engine pivot tray. Ensure that tray-securing bolt is in place.
- **Engine Oil Level**
 - Maintaining the engine components is essential to good performance and service life of the aerial platform.



WARNING

Beware of hot engine components.

Check oil level on dipstick

- Oil level should be in the “safe” zone. Add oil as needed. Refer to [Table 4.2b](#) for recommended oil type.

- **Engine Air Filter**
 - Ensure there are no loose or missing parts and there is no visible damage.
- **Fuel Leaks**
 - Ensure that there no fuel leaks.



DANGER

Engine fuels are combustible. Inspect the aerial platform in an open, well-ventilated area away from heaters, sparks and flames. Always have an approved fire extinguisher within easy reach.

- Ensure fuel tank, hoses and fittings show no visible damage and no evidence of fuel leakage.

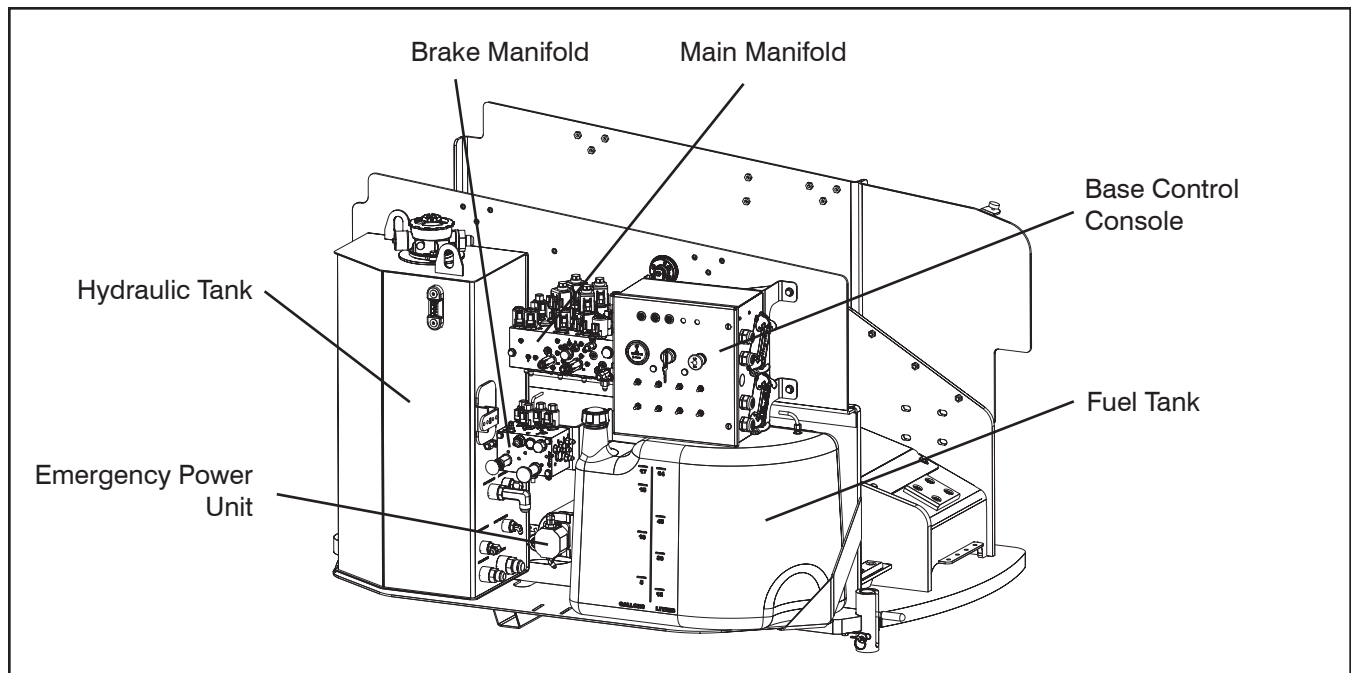

2.3-6 Control Compartment

- Ensure all compartment latches are secure and in proper working order.
- **Base Control Console**
 - Ensure all switches are returned to their neutral positions.
 - Ensure there are no loose or missing parts and there is no visible damage.
- **Hydraulic Tank**
 - Ensure hydraulic filler cap is secure.
 - Ensure tank shows no visible damage and no evidence of hydraulic leakage.
- **Hydraulic Oil**
 - Be sure that the boom is in the stowed position, and then visually inspect the sight gauge located on the side of the hydraulic oil tank.
 - The hydraulic oil level should be between the minimum and maximum marks on the sight glass. Add oil as needed. Refer to [Table 4.2b](#) for recommended oil type.
- **Brake and Main Manifolds**
 - Ensure all fittings and hoses are properly tightened and there is no evidence of hydraulic leakage.
 - Ensure there are no loose wires or missing fasteners.
- **Emergency Power Unit**
 - Ensure there are no loose or missing parts and there is no visible damage.
 - Ensure there are no loose wires or missing fasteners.
 - Ensure all fittings and hoses are properly tightened and there is no evidence of hydraulic leakage.
- **Fuel Tank**
 - Ensure fuel filler cap is secure.
 - Ensure tank shows no visible damage and no evidence of fuel leakage.

IMPORTANT

Before using your aerial platform ensure there is enough fuel for expected use.

- Ensure fuel filler cap is secure.
- Ensure tank shows no visible damage and no evidence of fuel leakage.

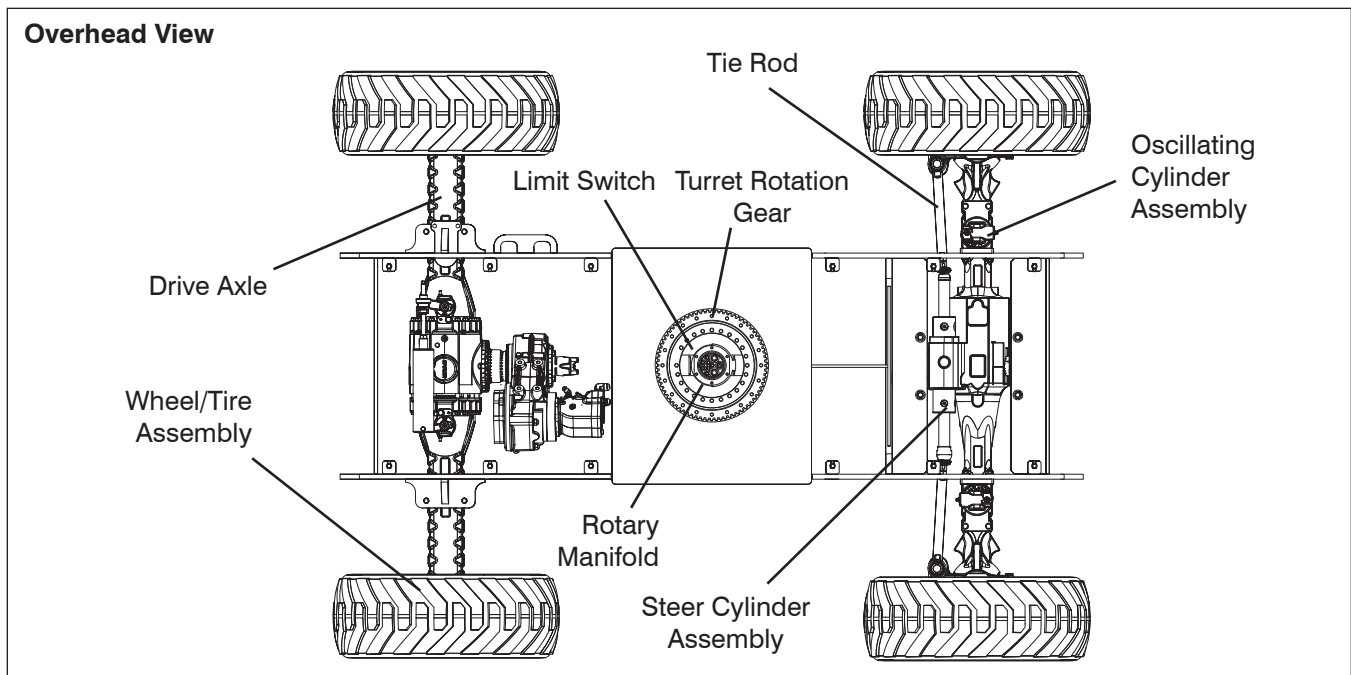

- **Fuel Leaks**
 - Ensure that there no fuel leaks.



Engine fuels are combustible. Inspect the aerial platform in an open, well-ventilated area away from heaters, sparks and flames. Always have an approved fire extinguisher within easy reach.

- Ensure fuel tank, shutoff valve, hoses and fittings show no visible damage and no evidence of fuel leakage.

2.3-7 Base

- **Turret Transportation Lock**
 - Ensure turret transportation lock is unlocked, there are no loose or missing parts and there is no visible damage.
- **Drive Axle**
 - Ensure drive axle is properly secured, there are no loose or missing parts, all fittings and hoses are properly tightened and there is no evidence of hydraulic leakage.

- **Oscillating Cylinder Assembly**
 - Ensure oscillating cylinder assembly is properly secured, there are no loose or missing parts, all fittings and hoses are properly tightened and there is no evidence of hydraulic leakage.

NOTE

Oscillating axle is locked when aerial platform is in work mode. Refer to [Figure 3-13](#). Axle Oscillation Diagram.

- **Steer Cylinder Assembly**
 - Ensure steer cylinder assembly is properly secured, there are no loose or missing parts, all fittings and hoses are properly tightened and there is no evidence of hydraulic leakage.
- **Tie Rod**
 - Ensure there are no loose or missing parts, tie rod end studs are locked and there is no visible damage.

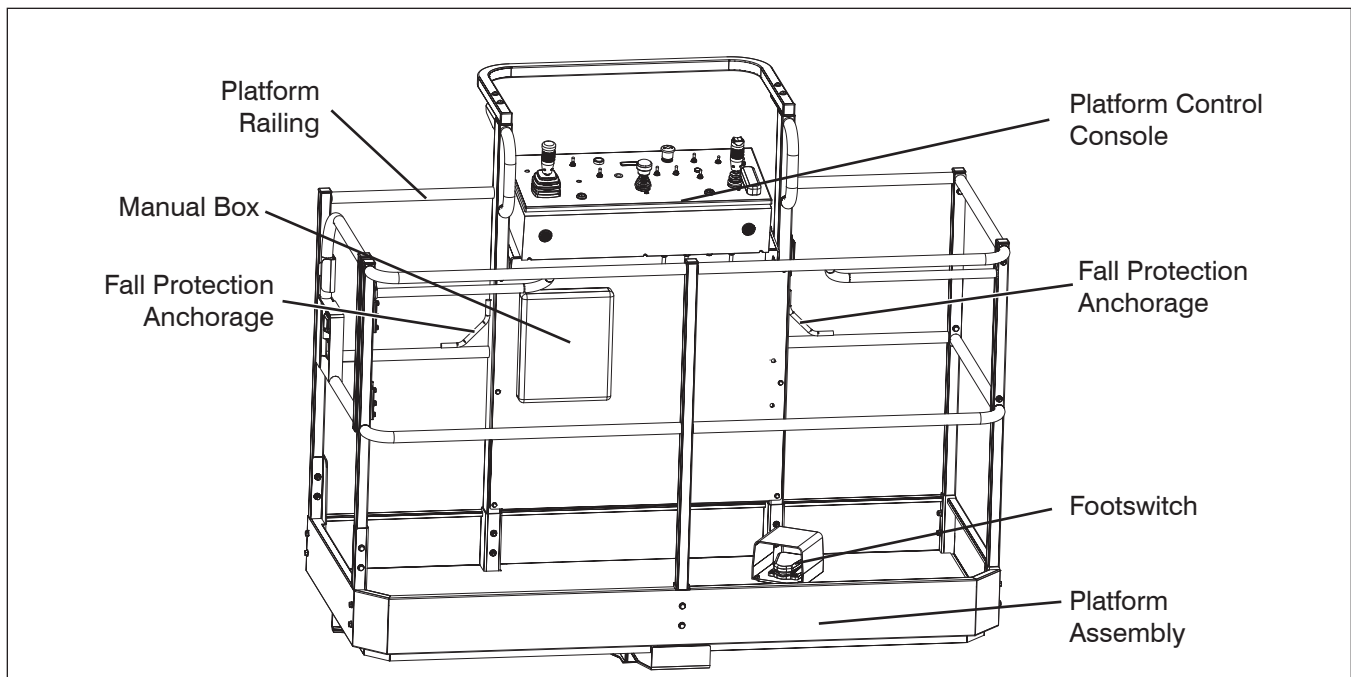

• **Wheel/Tire Assembly**

The aerial platform is either equipped with air tires or foam-filled tires. Tire and/or wheel failure could result in an aerial platform tip over. Component damage may also result if problems are not discovered and repaired in a timely fashion.

can adversely affect stability. Therefore, replace tires only with the exact Skyjack-approved type. Failure to operate with matched approved tires in good condition may result in death or serious injury.



WARNING

An over-inflated tire can explode and may cause death or serious injury.

- Check all tire treads and sidewalls for cuts, cracks, punctures and unusual wear.
- Check each wheel for damage and cracked welds.
- Check each lug nut for proper torque to ensure none are loose.

To maximize stability, it is essential to maintain proper pressure in all air-filled tires.

- Check each tire with an air pressure gauge and add air as needed.

Refer to [Table 4.4](#) for tire/wheel specifications.



WARNING

Intermixing tires of different types or using tires of types other than those originally supplied with this equipment

2.3-8 Manuals

Ensure a copy of operating manual, and other important documents are enclosed in manual storage box.

- Check to be sure manual storage box is present and in good condition.
- Ensure manuals are legible and in good condition.
- Always return manuals to the manual storage box after use.

2.3-9 Platform Assembly

- Ensure there are no loose or missing parts and there is no visible damage.
- Ensure all fasteners are securely in place.
- Ensure all railings are properly positioned and secured.
- Ensure gate is in good working order.
- Ensure there is no permanent deformation.
- Ensure footswitch is in good working order and has not been modified, disabled or blocked.

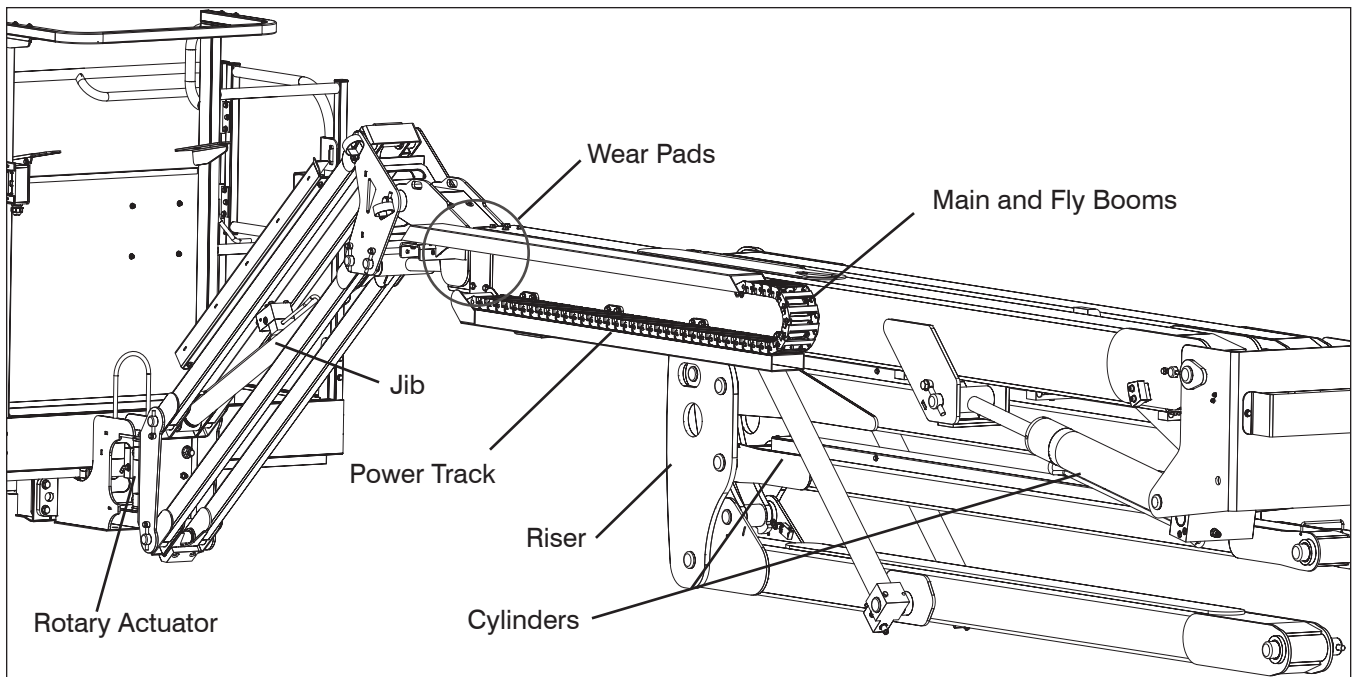

2.3-10 Platform Control Console

- Ensure all switches/controllers are returned to neutral and are properly secured.
- Ensure there are no loose or missing parts and there is no visible damage.

2.3-11 Rotary Actuator

- Ensure there are no loose or missing parts and there is no visible damage.
- Ensure all bolts and pins are properly tightened.
- Ensure all hoses are properly tightened and there is no evidence of hydraulic leakage.

2.3-12 Jib (If Equipped)

- Ensure there are no loose or missing parts and there is no visible damage.
- Ensure all bolts and pins are properly tightened.
- Ensure all hoses are properly tightened and there is no evidence of hydraulic leakage.

2.3-13 Boom

- Ensure there are no loose or missing parts and there is no visible damage.
- Ensure all bolts and pins are properly tightened.
- Ensure there are no visible cracks in welds or structure and there are no signs of deformation.

- Ensure all hoses are properly tightened and there is no evidence of hydraulic leakage.
- **Cylinders**
 - Ensure all cylinders are properly secured and there is no evidence of leakage.
- **Wear Pads**
 - Ensure all bolts are tight, there is no visible damage to the wear pads and that no parts are missing.
- **Hoses**
 - Ensure all hoses are properly tightened and there is no evidence of hydraulic leakage.
- **Power Track**
 - Ensure there are no loose or missing parts and there is no visible damage.

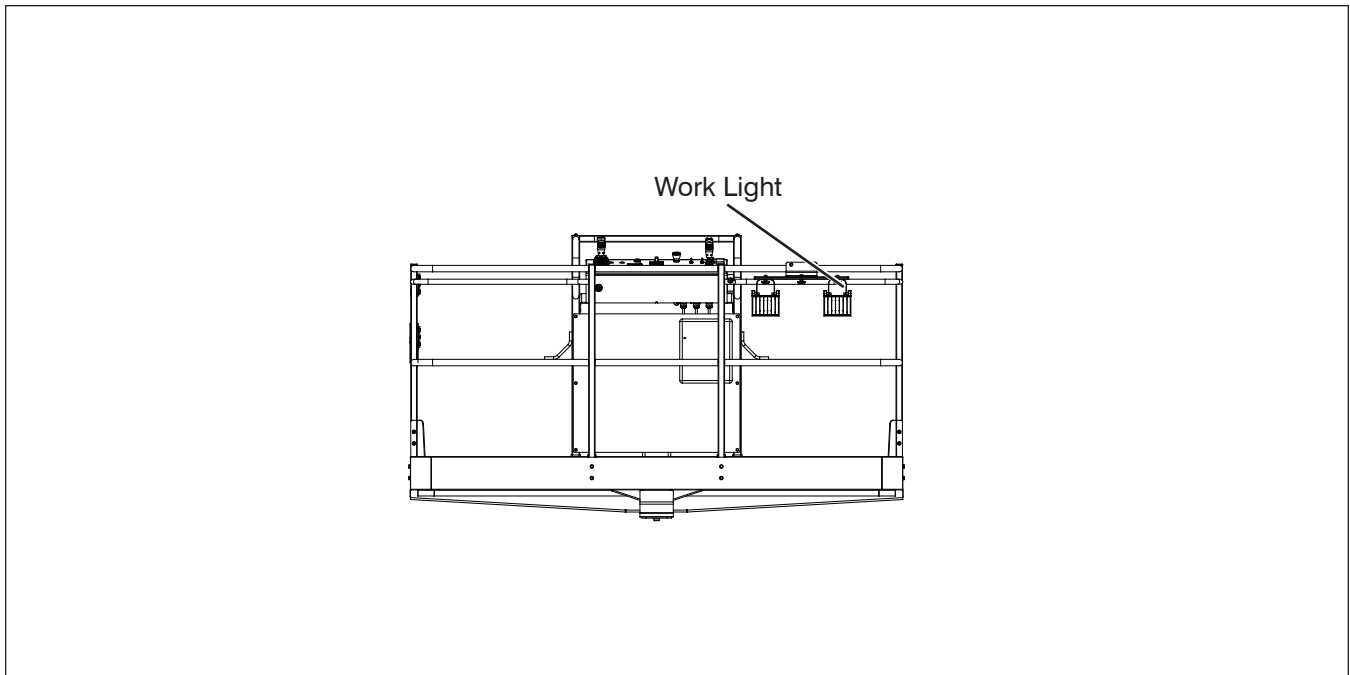

2.3-14 Special Options

- **Battery Warmer/Hydraulic Oil Heater (If Equipped)**
 - Ensure battery warmer/hydraulic oil heater cord is properly secured with no signs of visible damage and hydraulic leakage.
- **Work Light (If Equipped)**
 - Ensure lamps are properly secured with no signs of visible damage.
 - Ensure mounting bracket is properly secured.
 - Ensure there are no loose wires or missing fasteners.
- **Flashing Amber Light (If Equipped)**
 - Ensure lamp is properly secured with no signs of visible damage.

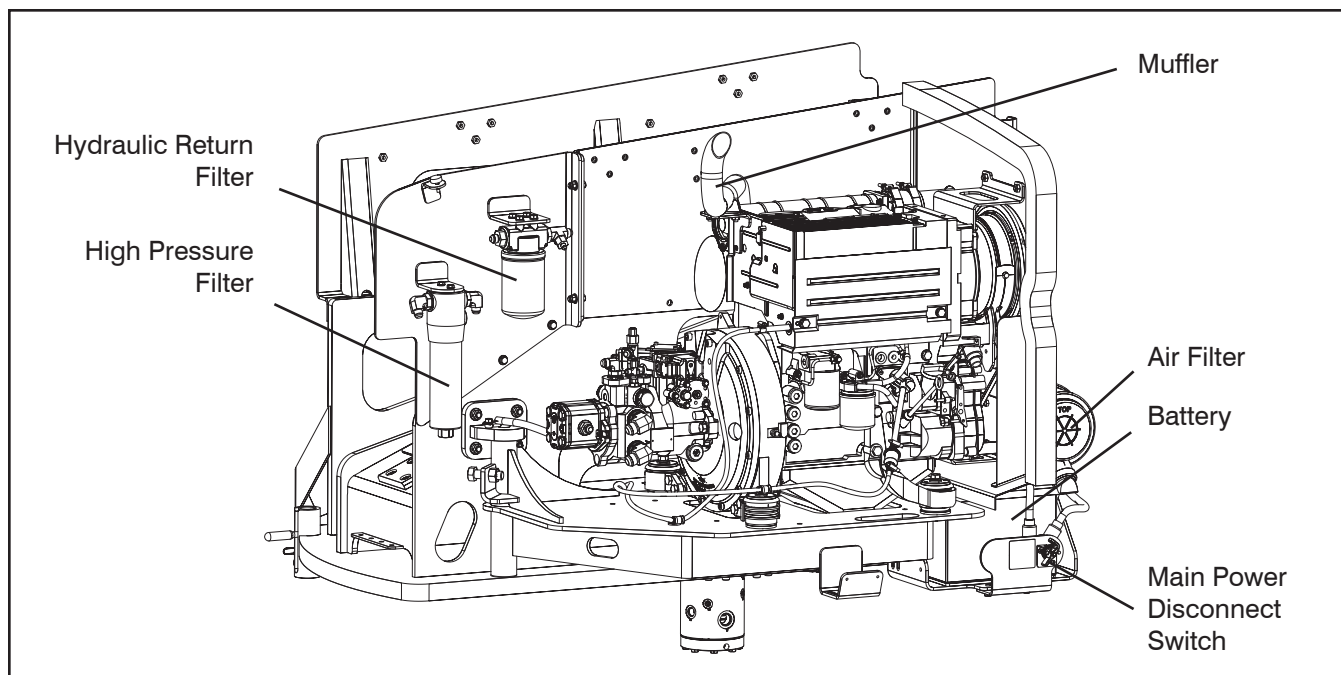

2.4 Function Tests

Function tests are designed to discover any malfunctions before aerial platform is put into service. The operator must understand and follow step-by-step instructions to test all aerial platform functions.

IMPORTANT

Never use a malfunctioning aerial platform. If malfunctions are discovered, aerial platform must be tagged and placed out of service. Repairs to aerial platform may only be made by qualified/competent repair personnel.

After repairs are completed, operator must perform a pre-operation inspection and a series of function tests again before putting aerial platform into service.

Prior to performing function tests, be sure to read and understand [Section 3.8 - Start Operation](#).



CAUTION

Allow engine to warm up for a few minutes at low speed before applying any load.



WARNING

Cold Weather - Caution must be exercised when operating aerial platform in cold temperature. Cold temperature can affect the performance of the aerial platform. Braking response and other functions may delay. Throughout the following procedures, test all functions several times until they are at acceptable operating performance.

NOTE

All-function motion alarm should sound while operating any boom and drive function.

2.4-1 Test Main Power Disconnect Switch



1. In engine compartment, turn main power disconnect switch to “○” off position.
Result: Aerial platform functions should not operate.
2. In engine compartment, turn main power disconnect switch to “↑” on position.

NOTE

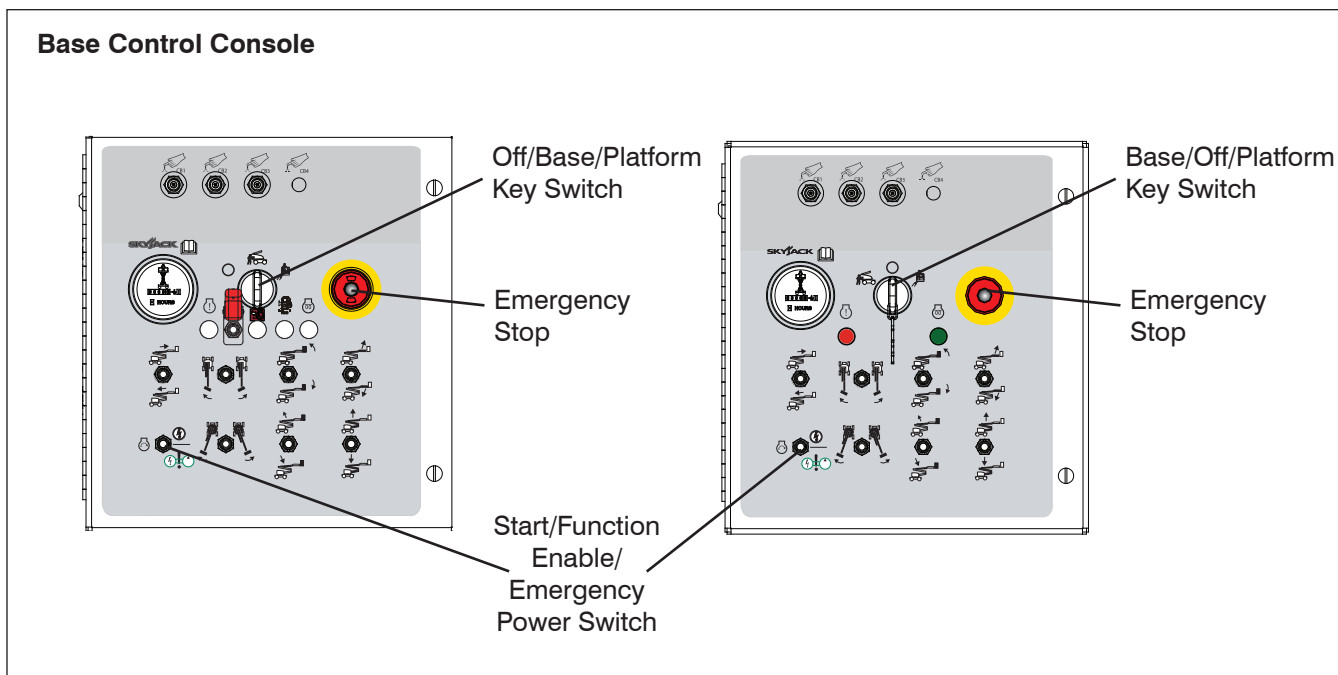
Close all cowlings before proceeding to next item.





2.4-2 Base Control Console

1. On platform control console, pull out “” emergency stop button.
2. For dual fuel engine, select fuel supply by moving fuel switch to either “” gasoline or “” liquid propane gas position.





WARNING

Ensure that you maintain three points of contact to mount/dismount platform.

- Test Base Emergency Stop Light
 1. On base control console, pull out “” emergency stop button.
Result: Emergency stop light should continuously illuminate.
 2. Turn off/base/platform (base/off/platform) key switch to “” base position.
 3. Start engine by selecting “” start position from start/function enable/emergency power switch.

- Test Base Emergency Stop



1. Push in “” emergency stop button.
Result: Engine should shut down and aerial platform functions should not operate.
2. Pull out “” emergency stop button and restart engine.

- Test Function Enable Switch and All Boom Functions





WARNING

Ensure that there are no personnel or obstructions in test area and there is sufficient room for boom to swing.

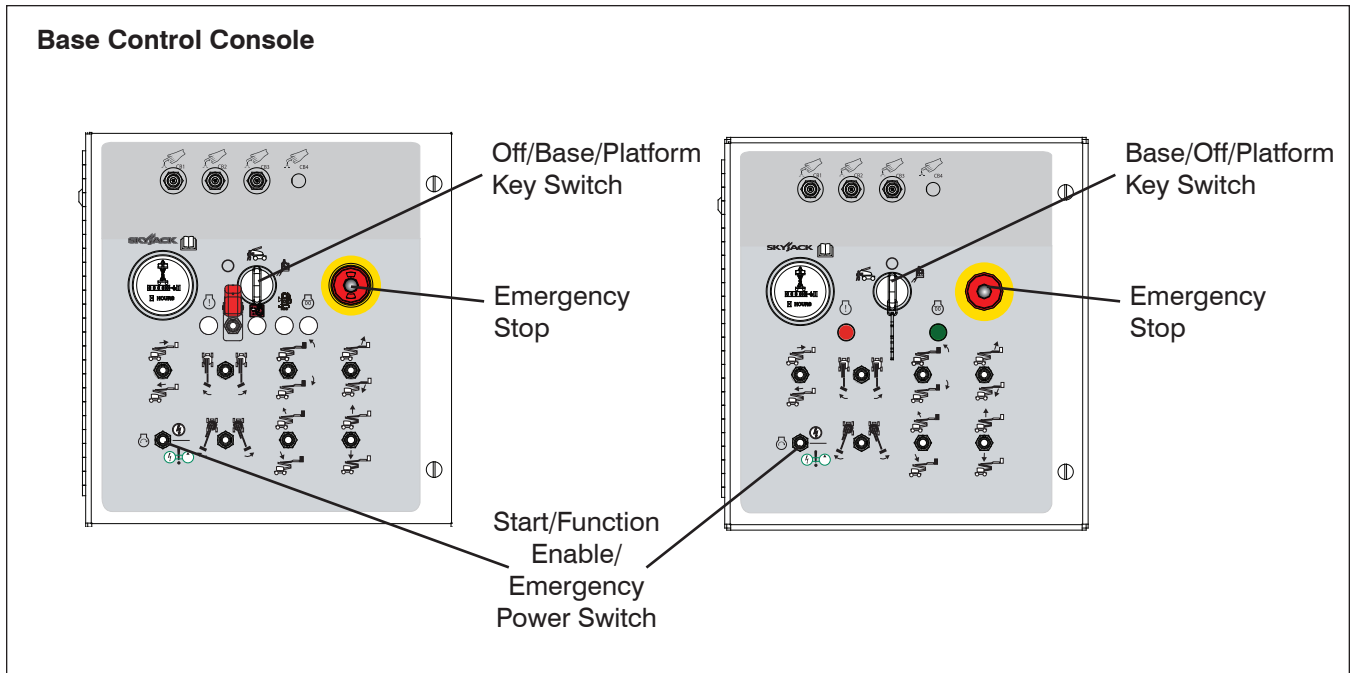

1. Do not hold “” function enable switch. Attempt to activate each boom and platform switch.
Result: All boom and platform functions should not operate.
2. Hold “” function enable switch and activate each boom and platform function.
Result: All boom and platform functions should operate as selected.



• **Test Platform Self-leveling**

1. Lower boom to stowed position.
2. Adjust platform to a level position using platform leveling switch.
3. Raise  and lower  main boom through a full cycle.
Result: Platform should remain level at all time.

• **Test Emergency Power**

1. On base control console, push in  emergency stop button to turn engine off.
2. On platform control console, push in  emergency stop button.







CAUTION

When operating on auxiliary power, do not operate more than one function at a time to avoid overloading 12-Volt auxiliary pump motor. Do not use emergency power unit continuously for more than two minutes.

NOTE

To conserve battery power, test each function through a partial cycle.

3. On base control console, pull out  emergency stop button.
4. On base control console, turn off/base/platform (base/off/platform) key switch to  platform position.
5. Select  emergency power position from start/function enable/emergency power switch and activate each boom function.
Result: All selected functions should operate.
6. Turn off/base/platform (base/off/platform) key switch to  base position.
7. Select  emergency power position from start/function enable/emergency power switch and activate each boom function.
Result: All selected functions should operate.

NOTE

The emergency power unit has two-minute duty cycle.

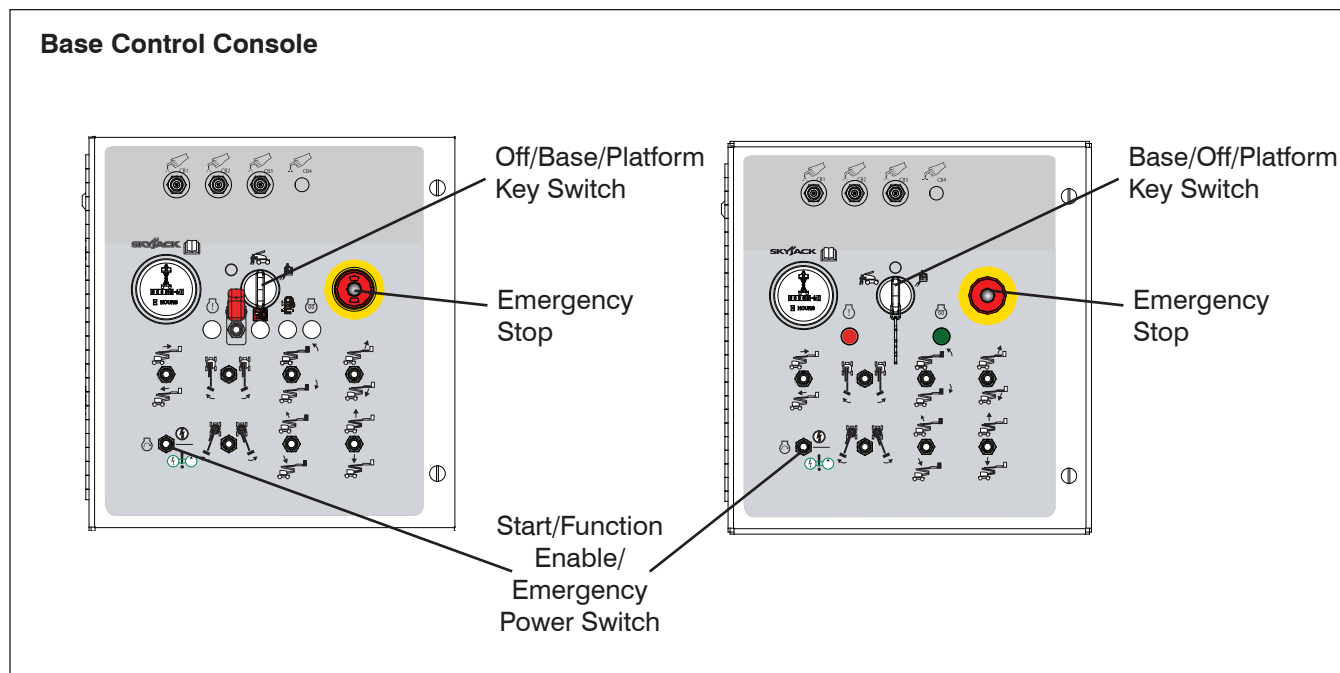

- **Test Off/Base/Platform (Base/Off/Platform) Switch**

1. Ensure both “” emergency stop buttons are pulled out.
2. Start engine.
3. On base control console, turn off/base/platform (base/off/platform) key switch to “” off position.
Result: Engine should shut down and aerial platform functions should not operate.
4. On base control console, turn off/base/platform (base/off/platform) key switch to “” platform position.



WARNING

Ensure that you maintain three points of contact to mount/dismount platform.

5. Enter platform and close gate.
6. On platform control console, select “” on position from engine start/on/off switch.

7. Select “” start position from engine start/on/off switch to start engine.
8. Dismount from platform.
9. On base control console, attempt to activate each boom and platform switch while holding function enable switch.
Result: All boom and platform functions should not operate while holding function enable switch.
10. Push in “” emergency stop button to turn engine off.
11. Pull out “” emergency stop button.

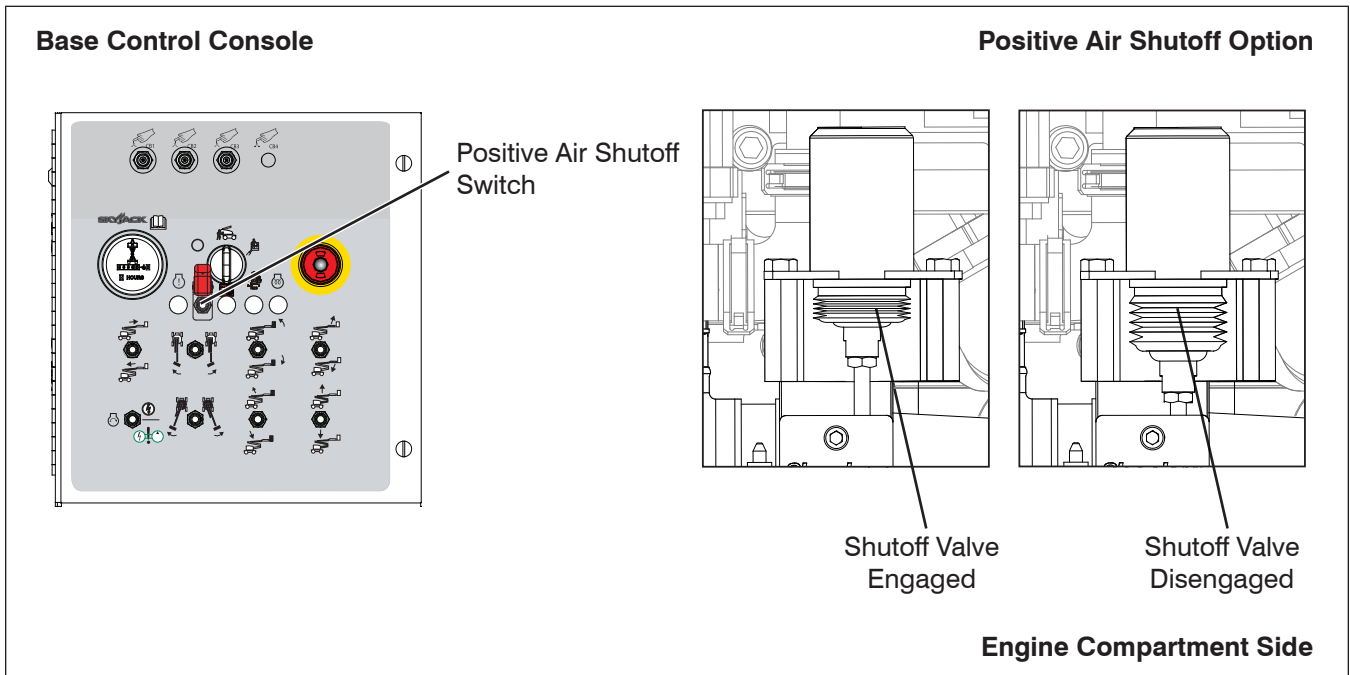

- Test Positive Air Shutoff (If Equipped)

CAUTION

This function test should NOT be performed while the engine is running.

1. Open engine compartment cover.
2. On the base control console, lift switch guard and push rocker switch to “on” position.
3. Push rocker switch to “off” position. LED light should continuously illuminate. Walk back to the engine compartment side of the aerial platform.
Result: The shutoff valve should disengage after 20 seconds (refer to shutoff valve diagrams).
4. Close engine compartment cover. Ensure switch is returned to “off” position and switch guard is down.

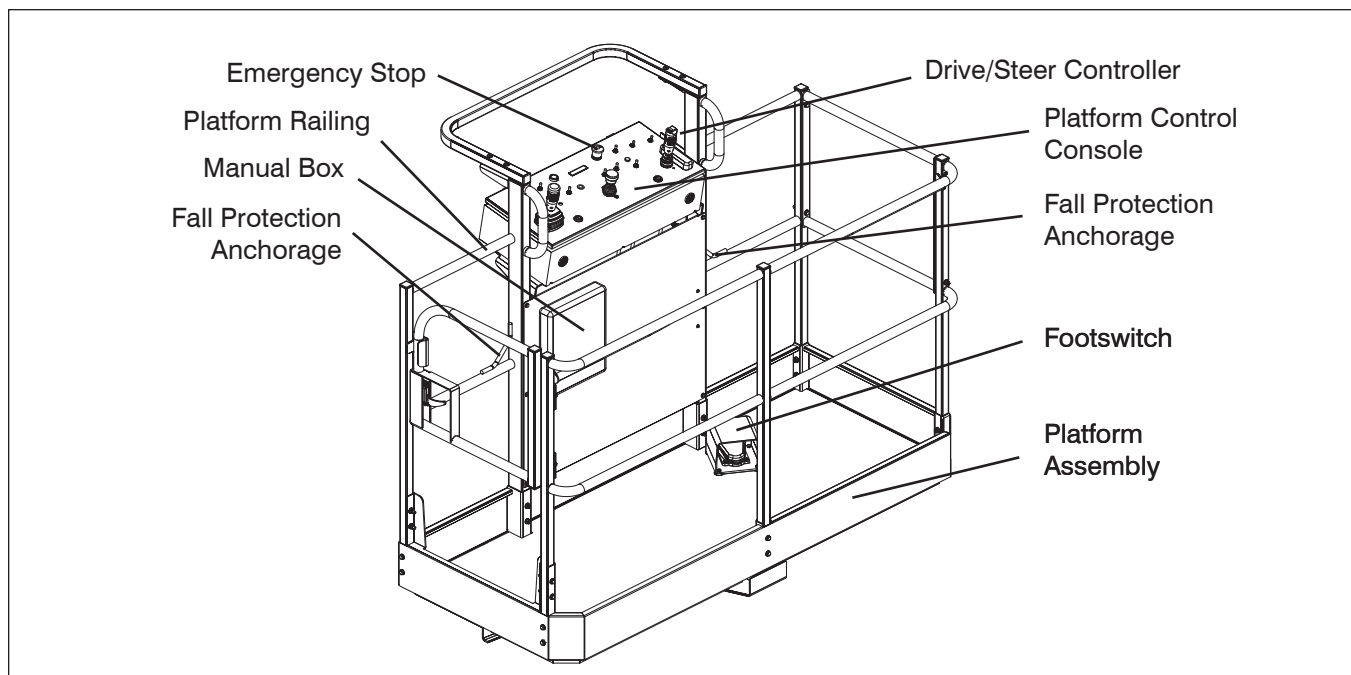

2.4-3 Platform Control Console



WARNING

Ensure that you maintain three points of contact to mount/dismount platform.

1. Enter platform and close gate.



WARNING

DO NOT operate any control on platform control console without proper fall protection secured to designated location in platform. Failure to avoid this hazard could result in death or serious injury!





WARNING

Ensure that there are no personnel or obstructions in test area and that there is sufficient room for boom to swing.

• Test Platform Emergency Stop Light



1. On platform control console, pull out “” emergency stop button.
Result: Emergency stop light should continuously illuminate.

• Test Platform Emergency Stop

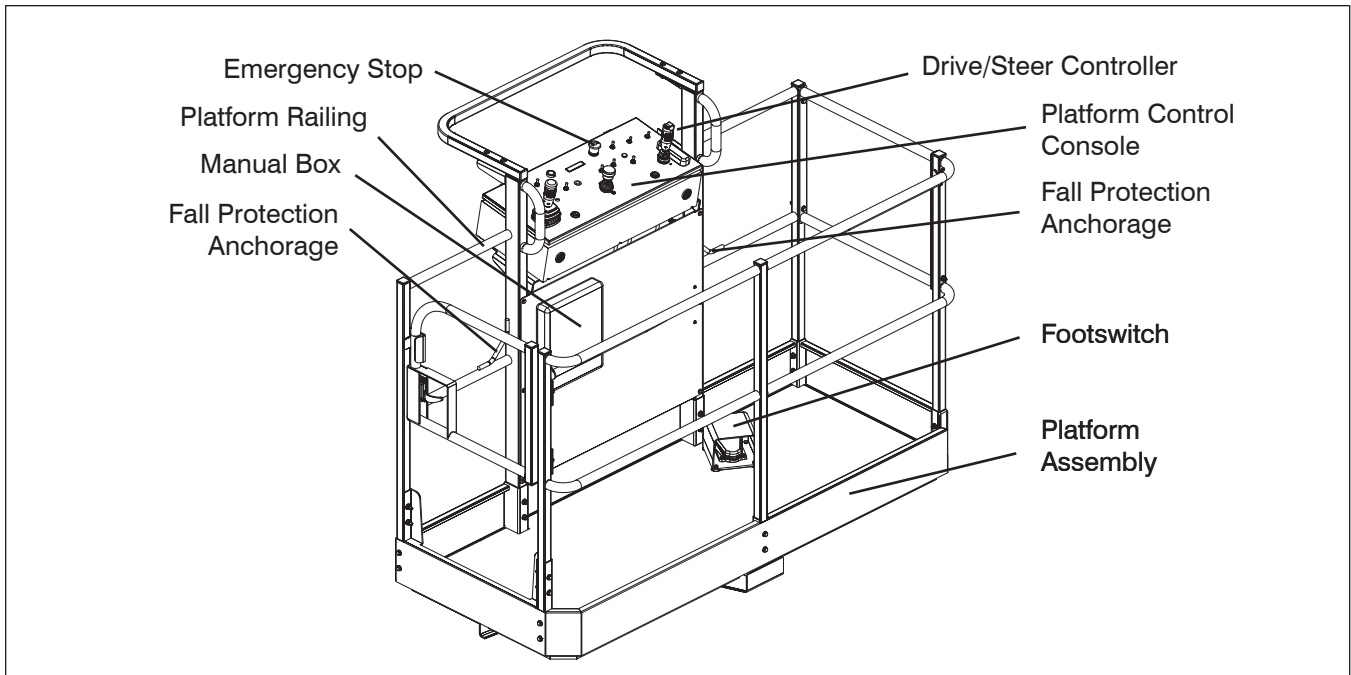
1. Start engine by selecting “” start position from engine start/on/off switch.
Result: Engine should start.
2. Push in “” emergency stop button.
Result: Engine should shut down and aerial platform functions should not operate.





• Test Footswitch

1. Ensure engine start/on/off switch is in “” on position.
2. Do not start engine.
3. Select generator on/off switch to off position (if equipped).
4. Depress and hold footswitch and attempt to start engine by selecting “” start position from engine start/on/off switch.
Result: Engine should not start.
5. Without depressing footswitch, try to start engine.
Result: Engine should start.
6. With engine running and without depressing footswitch, test each boom and platform function.
Result: Aerial platform functions should not operate.



NOTE

A 15-second anti-tiedown feature deactivates footswitch when operator depresses it for 15 seconds without activating any function.

• Test Engine Start/On/Off Switch

1. Ensure engine is running.
2. Select “” off position from engine start/on/off switch.
Result: Engine should shut down and platform control console is disabled.
3. Select “” on position from engine start/on/off switch.
Result: Platform control console is enabled.
4. Start engine by selecting “” start position from engine start/on/off switch.

• Test Steering

1. Restart engine.
2. Depress and hold footswitch.
3. Press rocker switch on top of drive/steer controller to “” left and “” right.
Result: Steer wheels should turn left and right.

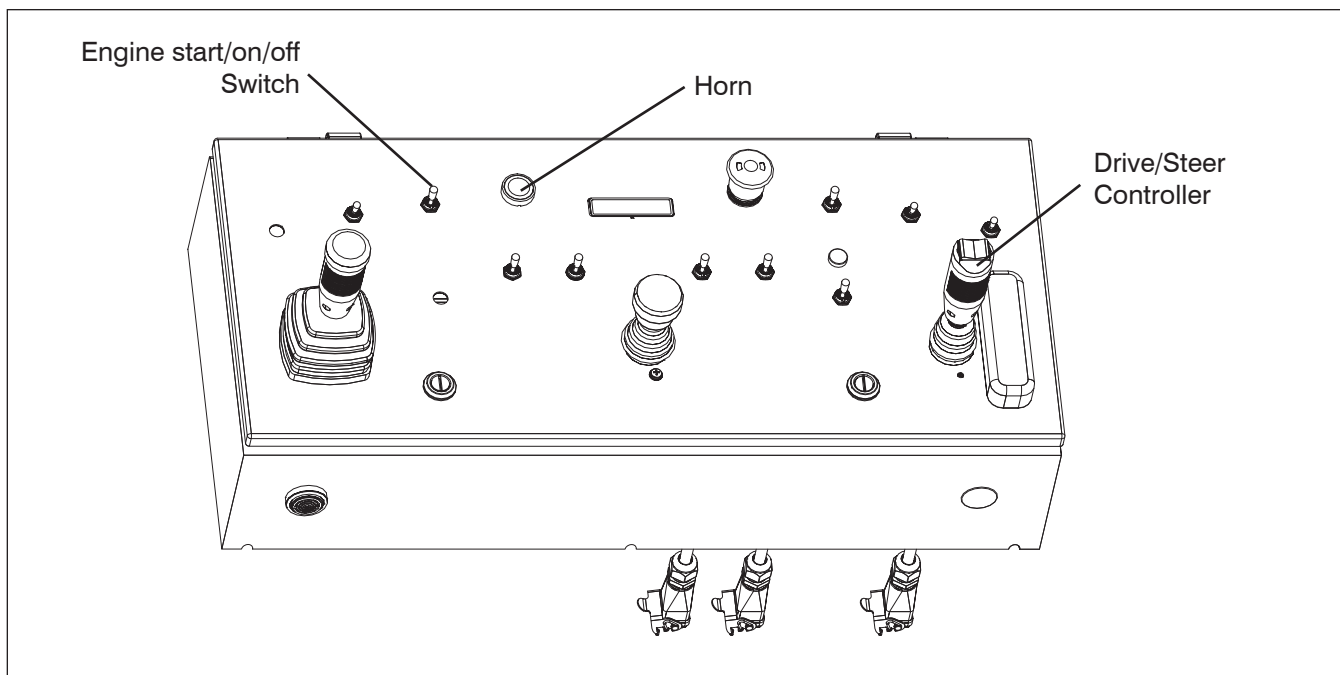



- Test Driving Function

**WARNING**



Ensure that there are no personnel or obstructions in the path of travel, including blind spots.

1. Ensure path of intended motion is clear.
2. Ensure boom is in stowed position and fly boom fully retracted.
3. Depress and hold footswitch.
4. Slowly move drive/steer controller in

“” forward or “” reverse direction until aerial platform begins to move, and then return handle to center position.

Result: Aerial platform should move in forward or reverse direction, and then come to a stop.

- Test Driving Speed

1. Depress and hold footswitch.
2. Raise “” main boom 4 ft. (1.2 m) above ground and then slowly move drive/steer controller to full drive position.
Result: The maximum achievable drive speed should be significantly less than stowed drive speed.
3. Lower boom to stowed position.
4. Extend “” fly boom approximately 12 in. (30 cm) and then slowly move drive/steer controller to full drive position.
Result: The maximum achievable drive speed should be significantly less than stowed drive speed.
5. Retract fly boom.
6. Raise riser approximately 4 ft. (1.2 m) above ground.
Result: The maximum achievable drive speed should be significantly less than stowed drive speed.

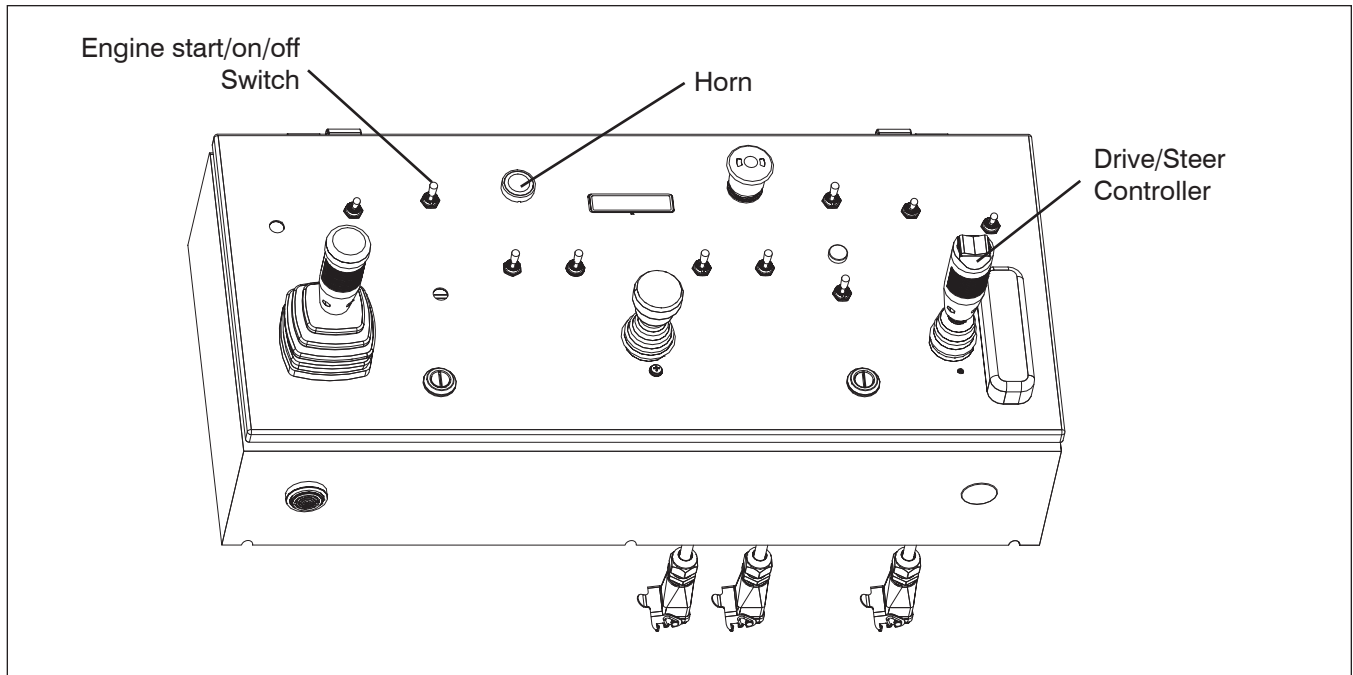

• Test Emergency Power







CAUTION

When operating on auxiliary power, do not operate more than one function at a time to avoid overloading 12-Volt auxiliary pump motor. Do not use emergency power unit continuously for more than two minutes.

NOTE

To conserve battery power, test each function through a partial cycle.

1. On platform control console, push in “” emergency stop button to turn engine off.
2. Pull out “” emergency stop button.
3. Select “” on position from engine start/on/off switch.
4. Depress and hold footswitch.

5. Turn “” emergency power switch to “” on position and activate each function control handle or switch.

Result: All boom and steer functions should operate. Drive functions should not operate.

NOTE

The emergency power unit has two-minute duty cycle.

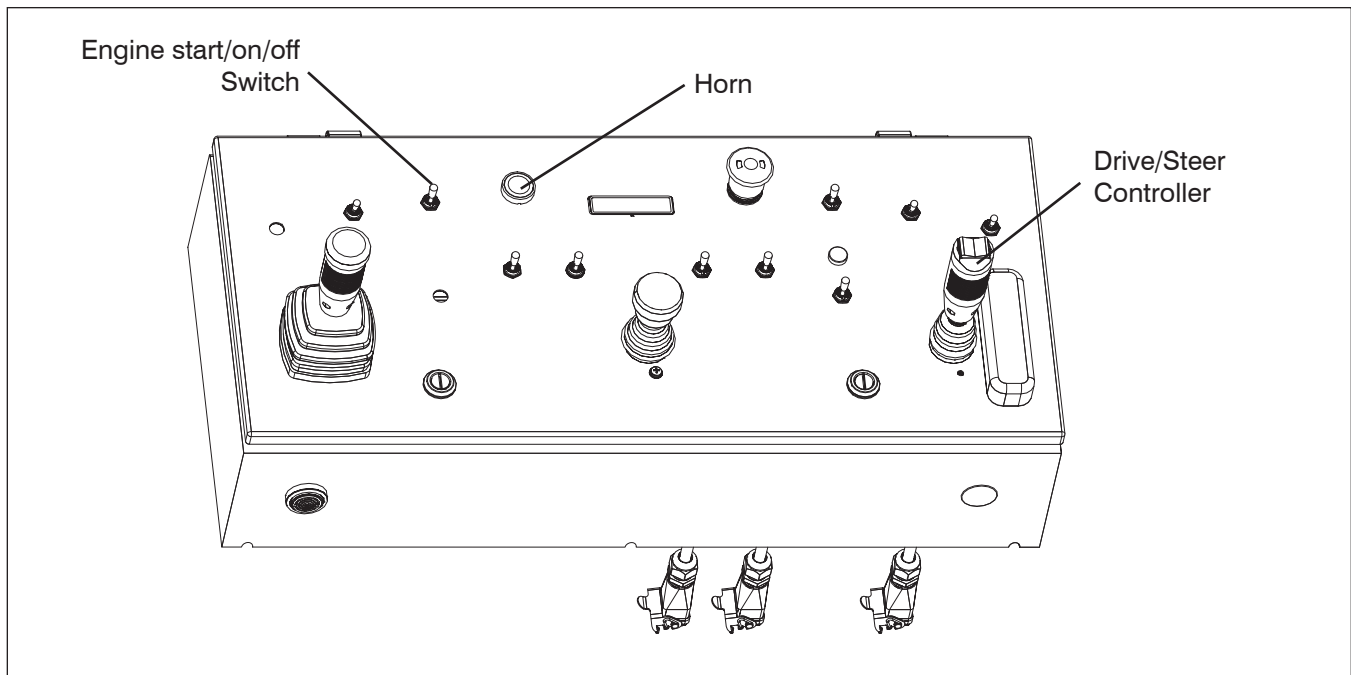

- **Test Horn**

1. Push “
 - **Test Brakes**



WARNING

Brakes will engage instantly when you release footswitch, causing aerial platform to stop immediately.

1. Restart engine.
2. Move aerial platform to a firm level surface to ensure similar traction on left and right.
3. Ensure boom is in stowed position.
4. Depress and hold footswitch and drive aerial platform first “
 5. Remove your foot from footswitch.

Result: Aerial platform should come to an abrupt stop. If aerial platform does not stop immediately, or if aerial platform pulls to one side while stopping, do not operate aerial platform until brake adjustments have been checked.

- **Test Manual Platform Leveling**

1. Depress and hold footswitch.
2. On platform leveling override switch, select “

Result: Platform should tilt up or down.

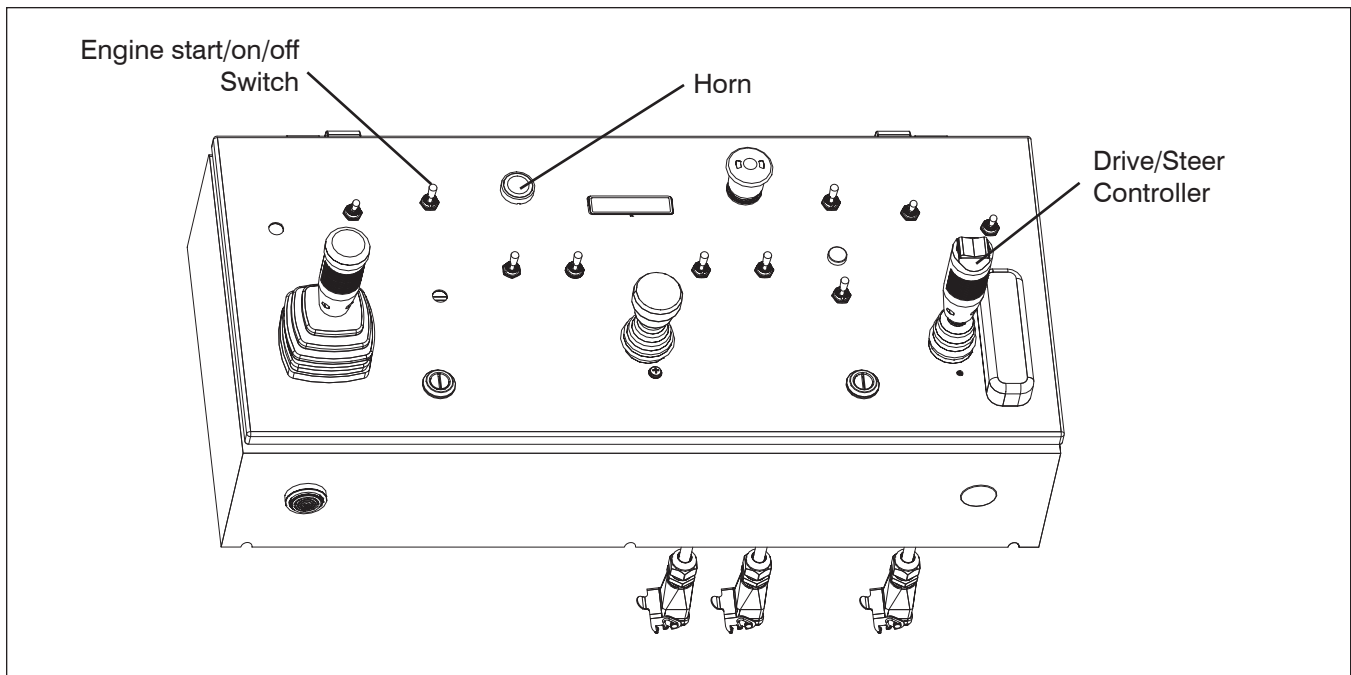



- Test Differential Lock Switch



WARNING

Before engaging differential lock, ensure drive/steer controller is in neutral position.

1. On platform control console, push differential lock switch forward  to the locked position and then release.
Result: Differential light should turn on. Differential lock should be engaged.
2. Pull differential lock switch backward  to the unlocked position and then release.
Result: Differential light should turn off. Differential lock will disengage when drive torque is released. Refer to Section 3 for operation.

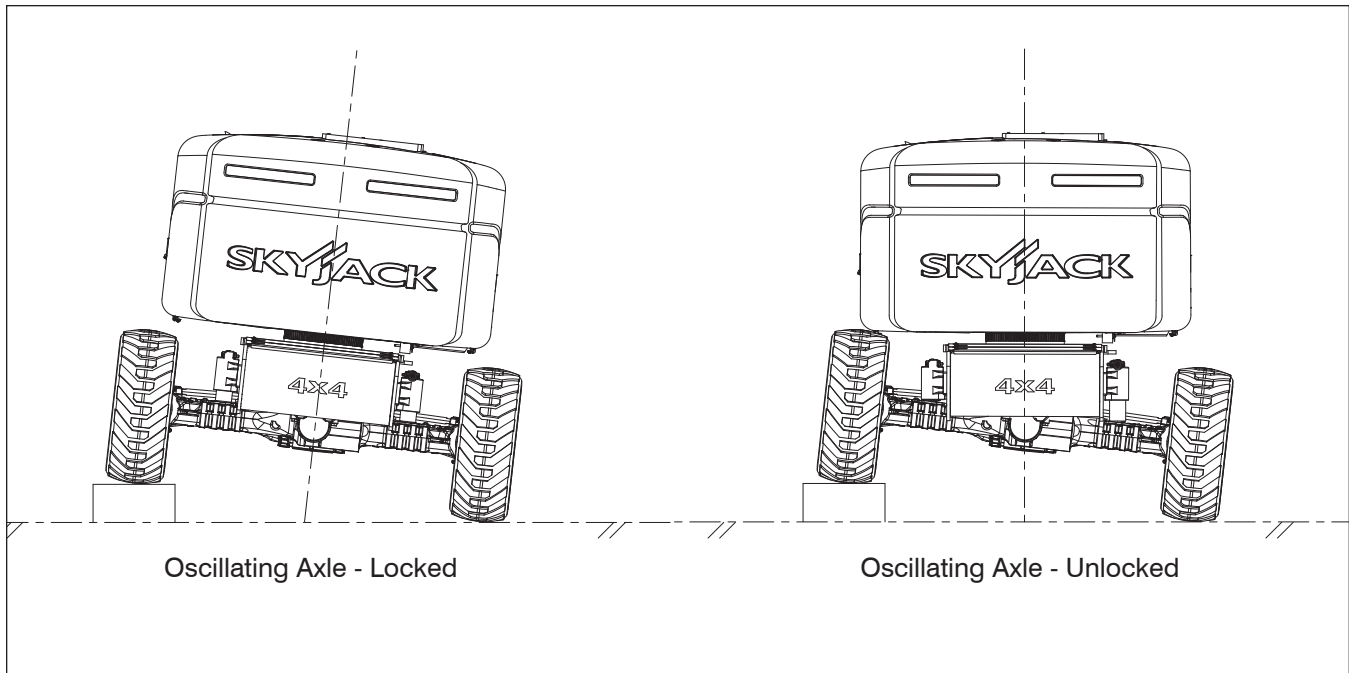

- Test Oscillating Axles



WARNING

DO NOT operate any control on platform control console without proper fall protection secured to designated location in platform. Failure to avoid this hazard could result in death or serious injury!

1. Extend fly boom 12 in. (30 cm) while on a firm level ground.
Result: The steer axle should be locked.
2. Drive one of the steer tires up onto a 6 in. (15 cm) block or curb.
Result: An appropriate tilt of the aerial platform chassis should occur.
3. Retract fly boom while in tilt position.
Result: The steer axle should unlock and the aerial platform chassis should level itself to ground.

2.5 Winching and Towing Procedure

This section provides the operator with procedure about winching and towing and on how to manually release brakes.



WARNING

Ensure boom is in stowed position before winching or towing. Sudden motion could cause aerial platform to become unstable. Death or serious injury could result.



WARNING

In emergency situations where aerial platform functions are not available and lowering is impeded by an obstacle, utmost care must be taken to move aerial platform far enough to clear obstacle. In such cases, operation must be extremely smooth with no sudden movements and must not exceed a speed of 2 in./sec (50 mm/sec).



WARNING

When pushing, winching or towing, do not exceed 2 mph (3.2 km/h).



WARNING

Do not winch or tow aerial platform on grade steeper than 45% (4WD).



WARNING

Do not winch or tow aerial platform onto a slope, or brake the towing vehicle rapidly. Do not pull aerial platform down an incline towards a winch.

1. Before winching or towing aerial platform, fully retract, lower and position boom over rear drive wheels in line with direction of travel.
2. Manually release brakes (refer to [Section 2.5-1](#)).
3. Remove wheel chocks or blocks, and then winch or tow aerial platform to desired location.

4. Position aerial platform on a firm and level surface.
5. Chock or block wheels to prevent aerial platform from rolling.
6. Apply brakes by pulling out black brake auto reset valve.

NOTE

Brakes automatically apply when platform controls are engaged.



WARNING

Brakes must be applied immediately after reaching desired location.

2.5-1 To Release Brakes Manually

Brakes must be manually disengaged for winching or towing.

**WARNING**

Do not manually disengage brakes if aerial platform is on a slope.

1. Ensure aerial platform is on level ground. Chock or block wheels to keep aerial platform from rolling.
2. Turn main power disconnect switch to “O” off position.

**CAUTION**

Do not use hydraulic power with brake disengaged.

3. Locate the bypass valve on the inboard side of the drive pump. Bypass the drive pump by loosening the valve stem (item 1 - marked with yellow paint) two revolutions counterclockwise.

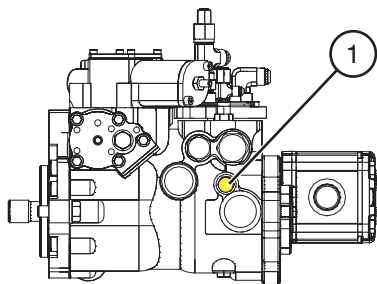

Figure 2-7. Drive Bypass Valve

**CAUTION**

Do not release brakes before disengaging drive motor!

4. Push in black brake valve plunger (item 2).

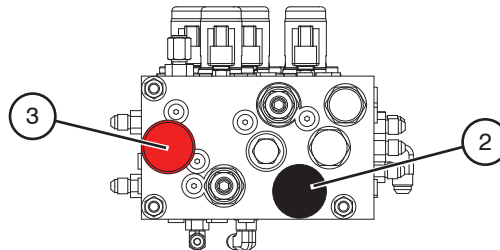

Figure 2-8. Brake Manifold

5. Actuate red hand pump (item 3) slowly by moving knob in and out until firm resistance is felt. Brake is now released.

**WARNING**

Brakes must be applied immediately after reaching desired location. Refer to Section 2.5 on how to reengage brakes.

2.6 Emergency Lowering Procedures

This section guides the operator on how to use emergency lowering system. This system allows platform lowering in the event of an emergency or engine malfunction.

NOTE





The emergency power unit has two-minute duty cycle.







CAUTION

Do not use emergency power unit continuously for more than two minutes.

At Base Control Console:

1. Ensure engine is off.
2. Pull out “” emergency stop button.
3. Select either “” base position or “” platform position from key switch.
4. Select “” emergency power position from start/function enable/emergency power switch and activate desired boom function.

At Platform Control Console:

1. Ensure engine is off.
2. Pull out “” emergency stop button.
3. Select “” on position from engine start/on/off switch.
4. Depress and hold footswitch.
5. Turn “” emergency power switch to “” on position and activate desired boom function.

NOTE

When platform is overloaded in work mode, emergency lowering is only available from base controls.

3.0 Operation

This section provides the necessary information needed to operate the aerial platform. It is important that the user reads and understands this section before operating the aerial platform.

3.1 General

In order for this aerial platform to be in good working condition, it is important that the operator meets the necessary qualifications and follow the maintenance and inspection schedule referred to in this section.

3.1-1 Operator Qualifications

- Only trained and authorized personnel shall be permitted to operate an aerial platform.
- Safe use of this aerial platform requires the operator to understand the limitations and warnings, operating procedures and operator's responsibility for maintenance. Accordingly, the operator must understand and be familiar with this operating manual, its warnings and instructions, and all warnings and instructions on the aerial platform.
- The operator must be familiar with employer's work rules and related government regulations and be able to demonstrate the ability to understand and operate this make and model of aerial platform in the presence of a qualified/competent person.

3.1-2 Operator's Responsibility for Maintenance



WARNING

Maintenance must be performed by trained and qualified/competent personnel who are familiar with mechanical procedures.

Death or serious injury could result from the use of an aerial platform that is not properly maintained or kept in good working condition.

- The operator must be sure that the aerial platform has been properly maintained and inspected before using it.
- The operator must perform all the daily inspections and function tests found in [Table 4.7](#), even if the operator is not directly responsible for the maintenance of this aerial platform.

3.1-3 Maintenance and Inspection Schedule

- The inspection points covered in [Table 4.7](#) indicate the areas of the aerial platform to be maintained or inspected and at what intervals the maintenance and inspections are to be performed.
- The actual operating environment of the aerial platform may affect the maintenance schedule.



WARNING

Use original or manufacturer-approved parts and components for the aerial platform.

3.1-4 Owner's Inspections

It is the responsibility of the owner to arrange daily, quarterly (or 150 hours) and annual inspections of the aerial platform. Refer to [Table 4.7](#) for recommended maintenance and inspection areas and intervals. A record of annual inspection is kept on a label located close to the base control console on the cowling. Refer to [Table 4.3](#) in this manual.

NOTE

Inspection scheduling requirements may vary. Owners must comply with local standards and regulations.

3.2 Major Components

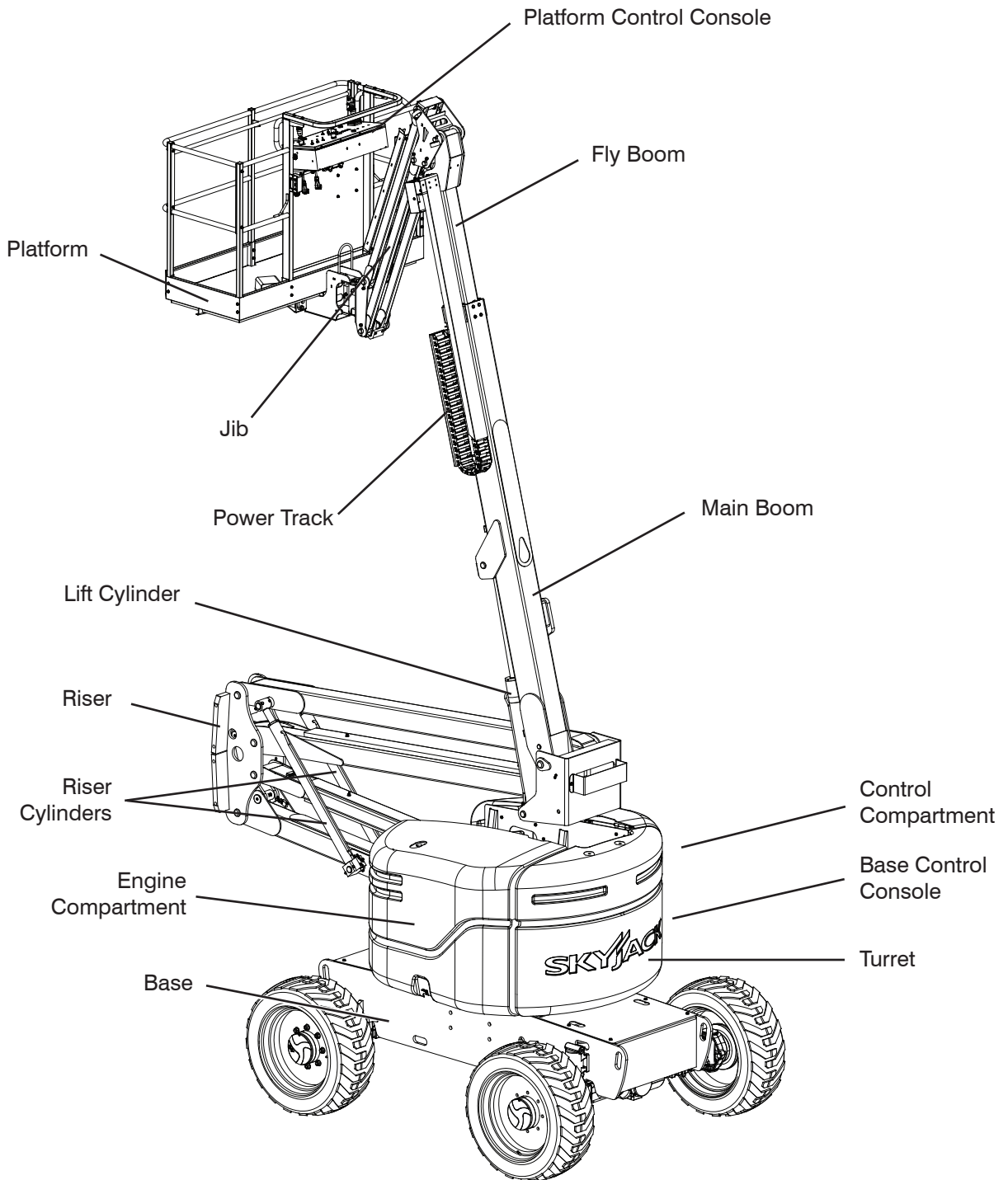

SKYJACK Articulating Boom

3.3 Major Assemblies

The aerial platform consists of four major assemblies: the base, turret, boom assembly and platform.

3.3-1 Base

The base is a rigid one-piece weldment. Models equipped with dual-fuel engine have mounting straps for propane tank on each side. The rear axle is hydraulic motor-driven and has a spring-applied, hydraulically released brakes. The front axle is steerable by a hydraulic cylinder. The rear axle is coupled to the front axle by a drive shaft.

3.3-2 Turret

The turret rotates 360 degrees continuously. Upon the turret are two compartments. One compartment contains the engine, hydraulic pumps and battery. The swing drive is in the center of the turret underneath the main boom. The other compartment contains the base control console, main hydraulic manifold, function valves, the hydraulic and fuel tanks.

3.3-3 Boom Assembly

The boom assembly consists of the riser, telescoping fly and main boom assembly. The riser is mounted on the turret with the main boom attached to the riser. The riser mechanism uses two double-acting hydraulic cylinders with holding valves to control vertical movement. AJ models are equipped with a 60 in. (152 cm) jib, controlled by a double-acting hydraulic cylinder.

3.3-4 Platform

The platform is constructed of a skid-resistant deck surface allowing visibility through the deck and a 43 in. (110 cm) high tubular steel railing system with mid rails and 6 in. (15 cm) toe boards. The platform can be entered through a swing gate at the side of the railing system. The platform can be rotated in either direction. An optional AC outlet is also located on the platform.

3.4 Serial Number Nameplate

The serial number nameplate, located at the rear of the aerial platform, lists the following:

- Model number
- Serial number
- Maximum capacities
- Maximum number of persons permissible on the platform
- Maximum manual force
- Aerial platform weight
- Maximum drivable height
- Maximum platform height
- System pressure
- Lift pressure
- Maximum wheel load
- Model year
- Voltage

3.5 Component Identification

The following descriptions are for identification, explanation and locating purposes only.

3.5-1 Manual Storage Box

This weather-resistant box is mounted under the control console on the platform. It contains operating manual and other important documents. The operating manual for this make and model of aerial platform must remain with the aerial platform and should be stored in this box.

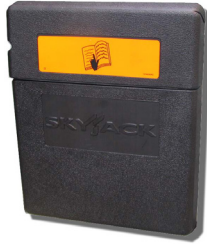

3.5-2 All Motion Alarm

This alarm produces an audible sound when any aerial platform function is activated. On aerial platforms with certain options, a flashing amber light will accompany this alarm.

3.5-3 AC Outlet on Platform (If Equipped)

This outlet is a source of AC power on the platform. The outlet is located on the right side of platform control console and the plug is located at the middle rear section of the turret.

3.5-4 Turret Transportation Lock

This locking device is located in the turret.

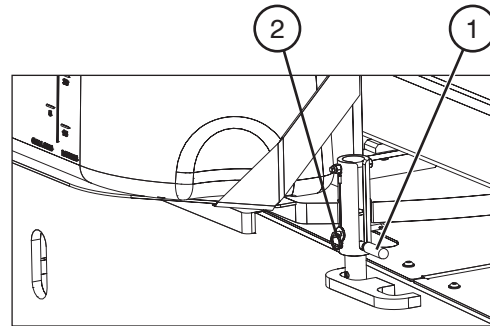

Figure 3-1. Turret Transportation Lock

1. **Turret Transportation Lock** - This locking device is used to lock turret in place during shipping only.
2. **Turret Transportation Lock Retaining Pin** - This retaining pin is used to hold transportation lock in either locked or unlocked position.

Refer to [Section 3.10-2](#) for procedure on how to lock the turret.

3.6 Component Identification (Optional Equipment/Attachments)

The following descriptions are for identification, explanation and locating purposes only.

3.6-1 Cold Weather Start (If Equipped)

The battery warmer/hydraulic oil heater cord is located on the engine compartment near the battery. This cord is plugged into the AC outlet at least 4 hours before starting engine when temperature gets below -11°C (+11°F).

3.6-2 Work Light (If Equipped)

The work light assembly is mounted on the railings of the platform.

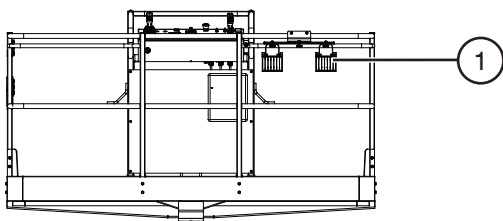

Figure 3-2. Work Light

1. **Work Light** - This light turns on when plugged into the AC outlet on the platform.



WARNING

Work lights are not intended to replace the ambient lighting required to navigate and operate this aerial platform.

3.6-3 Flashing Amber Light (If Equipped)

The flashing amber light is located on top of the turret of the aerial platform. This light flashes when boom function is activated. This works in conjunction with all motion alarm.

NOTE

The combined weight of attachment, panels, occupants and tools should not exceed platform rated capacity.

3.6-4 Tire Sealant (If Equipped)

This option is identified with a tire sealant label located at the rim of the wheel.

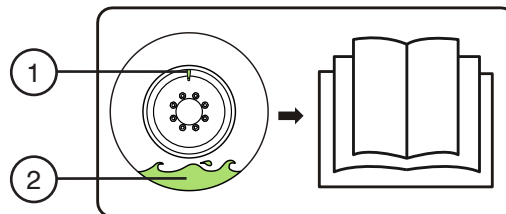

Figure 3-3. Tire Sealant Label

Tire Sealant Label - This label indicates that tire sealant is present inside the tires.

1. **Tire Valve Stem Cap** - This green valve stem cap is substituted onto air tires to indicate sealant has been installed.
2. **Sealant** - This symbol signifies that the tire is equipped with sealant.



WARNING

The operator **MUST** properly handle tires with sealant.

- When depressurizing, inflating or checking tire pressure, ensure that the valve stem is at the top to prevent sealant from entering the stem (refer to Figure 3-3).
- If the tire no longer holds pressure, replace the tire.



WARNING

The sealant contains propylene glycol. Do not ingest, inhale or get into eyes. If it gets into your eyes, flush with water for 15 minutes. Consult physician.

3.6-5 Hydraulic Generator (If Equipped)

To start the hydraulic generator:

1. Ensure that engine is running.
2. On platform control console, turn generator on/off switch to “” on position.

To restore normal operation:

1. On platform control console, turn generator on/off switch to “” off position.

NOTE

An engine shut down will turn the generator off. Normal boom functions are disabled while the generator is on.

3.6-6 Welder (If Equipped)

The welder is installed on the platform. Refer to welder’s operating manual for proper operation and maintenance.

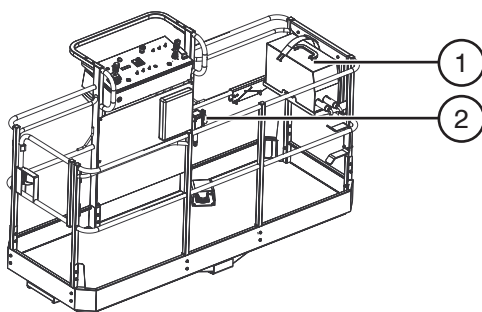

Figure 3-4. Welder

1. **Welder** - This equipment is plugged into its dedicated AC outlet on the platform.
2. **Welder AC Outlet** - This AC outlet is dedicated for the welder.

NOTE

In sub-zero temperatures, the hydraulic oil should be warmed, prior to operating the welder.

NOTE

This option adds 90 lb. (41 kg) to the platform. This weight must be included when determining the total load on the platform, including personnel and other materials.



WARNING

Only qualified persons should install, operate, maintain and repair the welder.



CAUTION

Breathing welding fumes and gases can be hazardous to your health.

3.6-7 Arctic Weather Package (If Equipped)

The heater plug is located on the engine compartment near the battery.

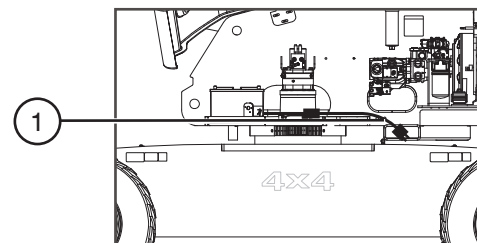

Figure 3-5. Heater Plug

1. **Battery/Hydraulic Oil/Engine Oil Heater Plug** - This cord is plugged into the AC outlet at least 3 hours before starting engine when temperature gets below -18°C (0°F).

3.7 Operator's Responsibility

It is the responsibility of the operator, prior to each work shift, to perform the following:

1. Visual and Daily Maintenance Inspections

- are designed to discover any damage of components before the aerial platform is put into service.
- are done before the operator performs the function tests.



WARNING

Failure to locate and repair damage, and discover loose or missing parts may result in an unsafe operating condition.

2. Function Tests

- are designed to discover any malfunctions before the aerial platform is put into service.

IMPORTANT

The operator must understand and follow the step-by-step instructions to test all aerial platform functions.

The operator should make a copy of the Operator's Checklist (see [Table 4.8](#)) and fill out the visual and daily maintenance inspections and the function tests sections while performing the items outlined in [Section 2.3](#) and [Section 2.4](#).

IMPORTANT

If aerial platform is damaged or any unauthorized variation from factory-delivered condition is discovered, aerial platform must be tagged and removed from service.

Repairs to the aerial platform may only be made by qualified/competent repair personnel. After repairs are completed, the operator must perform visual and daily maintenance inspections & function tests again.

Scheduled maintenance inspections shall only be performed by a qualified/competent person. (see [Table 4.7](#)).

3. Cold Weather Hydraulic System Warm Up



WARNING

Caution must be exercised when operating aerial platform in cold temperature. Cold temperature can affect the performance of the aerial platform. Braking response and other functions may delay.



CAUTION

Ensure hydraulic oil throughout system is warmed before operating aerial platform in low temperatures. Failure to heed this warning can lead to unexpected movements, product damage, death or serious injury.

Boom Functions:



WARNING

Be aware of overhead obstructions or other possible hazards around the aerial platform when lifting.

- Run engine at low throttle.
- Raise, lower, extend and retract boom slowly several times until boom functions are at acceptable operating performance.

Drive Functions:



WARNING

Ensure that there are no personnel or obstructions in the path of travel, including blind spots.

- Run engine (if applicable) in low throttle.
- Drive aerial platform forward and backward slowly several times until braking response is in safe operating performance.

3.8 Start Operation

Carefully read and completely understand the Operating Manual and all warnings and instruction labels (refer to labels section) on the aerial platform.



WARNING

DO NOT operate this aerial platform without proper authorization and training. Failure to avoid this hazard could result in death or serious injury.

Before operating this aerial platform, perform the following steps:

1. Visual and daily maintenance inspections (see Section 2.3)
2. Function tests (see Section 2.4)
3. Jobsite inspection
It is the responsibility of the operator to perform a jobsite inspection and avoid the following hazardous situations:
 - holes or drop-offs
 - ditches or soft fills
 - floor obstructions, bumps or debris
 - overhead obstructions
 - electrical cords, hoses and high voltage conductors
 - hazardous locations (see NFPA 505)
 - inadequate surface support to withstand all load forces imposed by the aerial platform
 - wind and weather conditions
 - the presence of unauthorized personnel
 - other possible unsafe conditions



WARNING

An operator should not use any aerial platform that:

- **does not appear to be working properly.**
- **has been damaged or appears to have worn or missing parts.**
- **has alterations or modifications not approved by the manufacturer.**
- **has safety devices which have been altered or disabled.**
- **has been tagged or locked out for non-use or repair.**







Failure to avoid these hazards could result in death or serious injury.

3.8-1 To Activate Base Control Console



WARNING

Ensure that you maintain three points of contact to mount/dismount the platform.

1. Enter platform and close gate.
2. On platform control console, pull out  emergency stop button.
3. For dual fuel engine, select fuel supply by moving fuel switch to either  gasoline or  liquid propane gas position.
4. In engine compartment, turn main power disconnect switch to “I” on position.
5. On base control console, turn off/base/platform (base/off/platform) key switch to  base position.
6. Pull out  emergency stop button.
7. Select  start position from start/function enable/emergency power switch until engine starts.



WARNING



DO NOT over crank the starter. If engine fails to start after multiple attempts, contact qualified/competent repair personnel.



CAUTION

Allow engine to warm up for a few minutes at low speed before applying any load.

3.8-2 To Rotate Platform Using Base Control Console



1. Activate and hold function enable switch  by pushing it to the right.
2. Push platform rotation switch to either  left or  right position. Release switch to stop.

3.8-3 To Rotate Turret Using Base Control Console



WARNING



When rotating the turret, ensure that there are no personnel or obstructions in the path of rotation, including blind spots.

1. Activate and hold function enable switch “” by pushing it to the right.
2. Push turret rotation switch to either “” clockwise or “” counterclockwise position. Release switch to stop.



NOTE

Turret can be rotated continuously 360 degrees.



3.8-4 To Move Jib (If Equipped) Up and Down Using Base Control Console

1. Activate and hold function enable switch “” by pushing it to the right.
2. Push jib up/down switch to either “” up or “” down position. Release switch to stop.



3.8-5 To Move Riser Up and Down Using Base Control Console

1. Activate and hold function enable switch “” by pushing it to the right.
2. Push riser up/down switch to either “” up or “” down position. Release switch to stop.



3.8-6 To Raise or Lower Main Boom Using Base Control Console

1. Activate and hold function enable switch “” by pushing it to the right.
2. Push main boom raise/lower switch to either “” raise or “” lower position. Release switch to stop.

3.8-7 To Extend or Retract Fly Boom Using Base Control Console

1. Activate and hold function enable switch “” by pushing it to the right.
2. Push fly boom extend/retract switch to either “” extend or “” retract position. Release switch to stop.

3.8-8 To Level Platform Manually Using Base Control Console

1. Activate and hold function enable switch “” by pushing it to the right.
2. Push platform leveling override switch to either “” up or “” down position. Release switch to stop.

3.8-9 To Operate Using Emergency Power Switch at Base Control Console

This is a momentary-type switch. This switch allows all functions except the drive function to operate in the event of engine malfunction. Refer to [Section 2.6](#) for the emergency lowering procedure.

NOTE



The emergency power unit has two-minute duty cycle.



CAUTION

Do not use emergency power unit continuously for more than two minutes.

3.8-10 To Activate Platform Control Console

1. In engine compartment, turn main power disconnect switch to “I” on position.
2. On base control console, turn off/base/platform (base/off/platform) key switch to “” platform position.
3. On base control console, pull out “” emergency stop button.



WARNING

Ensure that you maintain three points of contact to mount/dismount the platform.



WARNING

DO NOT operate any control on operator’s control console without proper fall protection secured to the designated location in the platform. Failure to avoid this hazard could result in death or serious injury.

4. Enter platform and close gate.
5. Attach body harness lanyards of each occupant to fall protection anchorage points. Rated for one (1) person per anchorage.
6. On platform control console, pull out “” emergency stop button.

7. Push and hold “” start position from start/on/off switch until engine starts.





WARNING

DO NOT over crank the starter. If engine fails to start after multiple attempts, contact qualified/competent repair personnel.

NOTE

Engine will not start if you are pressing down on the footswitch.

8. Select desired engine RPM using throttle switch: “” high or “” low.



WARNING

DO NOT drive or steer the aerial platform when the platform position does not allow you a clear view of the base. Your area of operation should be cordoned from other personnel or equipment.

3.8-11 To Drive Forward or Reverse





WARNING

- Refrain from climbing hills with slope greater than 20%.
- When climbing high grades:
 - all booms must be fully stowed.
 - restrict platform capacity to 300 lb. (136 kg).



CAUTION



When you are in the platform and positioned over an axle, the direction you are facing will be forward.

1. Depress and hold footswitch.
2. On platform control console, push and hold drive/steer controller in this direction “” to drive forward or “” to drive backward.
3. Release controller handle to stop.

 **DANGER**

The drive orientation can change when the turret is swung 90 degrees off center of the normal driving position (roughly when boom is swung past the rear tire). Drive re-orientation will not occur while driving and rotating until the joystick is released for 6 seconds or when the footswitch is released.



3.8-12 To Steer

1. Depress and hold footswitch.
2. On platform control console, press rocker on top of drive/steer controller in this direction  to steer left or  to steer right.



NOTE

Driving and steering may be active at the same time.



3.8-13 To Move Jib (If Equipped) Up and Down Using Platform Control Console

1. Depress and hold footswitch.
2. On jib up/down switch, select  to move jib up or  to move jib down. Release switch to stop.



3.8-14 To Move Riser Up and Down Using Platform Control Console

1. Depress and hold footswitch.
2. On riser up/down switch, select  to move riser up or  to move riser down. Release switch to stop.



3.8-15 To Extend or Retract Fly Boom Using Platform Control Console

1. Depress and hold footswitch.
2. On fly boom extend/retract switch, select  to extend fly boom or  to retract fly boom. Release switch to stop.

3.8-16 To Rotate Platform Using Platform Control Console

1. Depress and hold footswitch.
2. On platform rotation switch, select  to rotate platform left or  to rotate platform right.

3.8-17 To Level Platform Manually Using Platform Control Console

1. Depress and hold footswitch.
2. On platform leveling override switch, select  up position to tilt platform up or  down position to tilt platform down.

3.8-18 To Raise or Lower Main Boom Using Platform Control Console

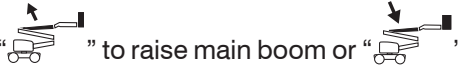
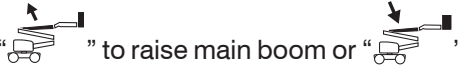
1. Depress and hold footswitch.
2. Push and hold boom/turret controller in this direction  to raise main boom or “” to lower main boom.
3. Release controller handle to stop.

3.8-19 To Sound Horn

1. Press “” horn pushbutton to sound horn. Release pushbutton to stop sounding horn.

3.8-20 To Rotate Turret Using Platform Control Console



WARNING

When rotating the turret, ensure that there are no personnel or obstructions in the path of rotation, including blind spots.

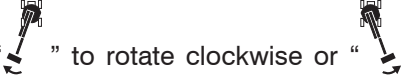
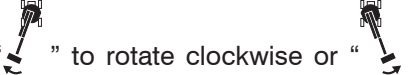
1. Depress and hold footswitch.
2. Push and hold boom/turret controller in this direction “” to rotate clockwise or “” to rotate counterclockwise.
3. Release controller handle to stop.

NOTE

Turret can be rotated continuously 360 degrees.

3.8-21 To Operate Using Emergency Power Switch at Platform Control Console

This is a momentary-type switch. This switch allows all functions except drive function to operate in the event of engine malfunction. Refer to [Section 2.6](#) for the emergency lowering procedure.

NOTE

The emergency power unit has two-minute duty cycle.



CAUTION

Do not use emergency power unit continuously for more than two minutes.

3.8-22a To Engage Differential Lock Switch

1. Depress and hold footswitch.
2. On platform control console, push differential lock switch forward “” to the locked position and then release.

3.8-22b To Disengage Differential Lock Switch

1. Ensure path of intended motion is clear.
2. Depress and hold footswitch.
3. Pull differential lock switch backward “” to the unlocked position and then release.

NOTE

To disengage differential lock mechanism, it may be necessary to release drive torque. This can be accomplished by operating drive (alternating directions) and/or steer functions (alternating directions).



3.8-23 Shutdown Procedure

1. Completely retract boom and lower platform.



WARNING

Ensure that you maintain three points of contact to mount/dismount the platform.

2. Push in “” emergency stop button on platform control console and on base control console.
3. Turn off/base/platform (base/off/platform) key switch to “” off position. Remove key.
4. Turn main power disconnect switch to “” off position.

For aerial platform with cold weather start option:

NOTE

When temperature gets below -11°C (+11°F), ensure aerial platform is parked close to AC outlet.

5. Plug in battery warmer/hydraulic oil heater into AC outlet at least 4 hours before starting engine.

3.9 Refueling Procedure

This section provides the operator with the procedure on how to refuel the engine with regular fuel and install the propane cylinder.

IMPORTANT

Before using the aerial platform ensure there is enough fuel to finish the job.



WARNING

Follow all local and national regulations for propane handling.



WARNING

Failure to heed the following safety precautions could result in death or serious injury:

- **Use extreme caution while refueling aerial platforms.**
- **Ensure engine and all systems are turned off before refueling.**
- **Refuel aerial platform only in a well ventilated area away from open flame and other sources of ignition, authorized by your employer and supervisor.**
- **Liquid propane gas fuel is a gas that is heavier than air. It settles in low spots. Any flame or spark could cause a fire that could cause serious injury.**
- **When changing liquid propane gas cylinder, check all connections for damage or missing parts. Never try to start an aerial platform if you smell gas.**
- **For gasoline engine models, use only unleaded gasoline with an octane rating 87 or higher.**



WARNING

Do not smoke in an area where aerial platforms are stored or refueled.

3.9-1 Regular Fuel

1. Ensure engine and all systems are turned off and emergency stop buttons are depressed.
2. Open fuel compartment door and remove fuel cap.
3. Carefully pour fuel into tank ensuring that no spillage occurs.
4. Securely replace fuel cap.
5. Ensure there are no leaks in the fuel system.
6. Wipe up any spilled fuel.
7. Dispose of rags in an approved container.

Protection of Environment from Chemical Dangers



WARNING

Gasoline, diesel fuel, engine oil and hydraulic fluid are chemicals, which can contaminate the environment. If they are spilled during filling and reach the water, they can cause damage to the environment, e.g., death of fish. For such damage, the party responsible is liable! Therefore, gasoline, diesel fuel, engine oil or hydraulic fluid must not get into the sewage system, streams, rivers or other surface water. For that reason, immediately remove the dripped off or spilled gasoline, diesel fuel, engine oil or hydraulic fluid with appropriate means and dispose of these means according to the regulations.

3.9-2 Propane

**WARNING**

Follow all local and federal regulations for propane handling.

To remove a propane cylinder:

1. Ensure engine and all systems are turned off and emergency stop button is depressed.
2. Turn propane cylinder's main valve clockwise to shut off fuel supply to engine.
3. Start engine and allow it to stop naturally. Restart engine to ensure fuel lines are empty.
4. Disconnect hose from empty propane cylinder by detaching the coupling. Turn fitting counterclockwise.
5. Loosen two propane cylinder straps by pulling up on the metal clips. Disconnect straps from hooks.
6. Remove the propane cylinder.

To install a propane cylinder:

1. Ensure engine and all systems are turned off and emergency stop button is depressed.
2. Place propane cylinder on bracket or in compartment.
3. Ensure metal peg on bracket or compartment is inserted into propane cylinder rim.
4. Reconnect propane cylinder straps to hooks and fasten tightly.
5. Attach coupler to propane cylinder and turn clockwise to tighten fitting.
6. Apply soap water or neutral detergent to pipe connection and cylinder.
7. Open valve 1/4 turn counterclockwise and check for any gas leaks.
8. Wipe off soap water or detergent after inspection is completed.
9. Open main valve fully if there are no leaks.

NOTE

The aerial platform is now ready for use by an authorized, qualified operator who has read and completely understands all of [Section 3](#) operations in this manual.

3.10 Loading/Unloading

Know and heed all national, state/provincial and local rules which apply to transporting of aerial platforms.

Only qualified/competent personnel shall operate the aerial platform during loading/unloading.

Be sure vehicle capacity and loading equipment hoists, chains, straps, etc., are sufficient to withstand maximum aerial platform weight.

The transport vehicle must be parked on a level surface and must be secured to prevent rolling while aerial platform is being loaded or unloaded.

3.10-1 Loading and Tie-down

1. Lock turret using turret transportation lock (refer to [Section 3.10-2](#)).
2. Turn key switch to “○” off position and remove key before transporting.

3. Turn main power disconnect switch to “○” off position.
4. Chock aerial platform wheels (if necessary).
5. Remove all loose items.
6. Anchor down aerial platform to transport surface using tie-down points (refer to [Figure 3-6](#)).
7. Secure boom from side-to-side movement using lower platform mount between boom end and platform. Do not use excessive downward force when securing boom section.



WARNING

Inspect aerial platform for loose or unsecured items.

NOTE

For loading and unloading using a winch line, refer to [Section 2.5](#).

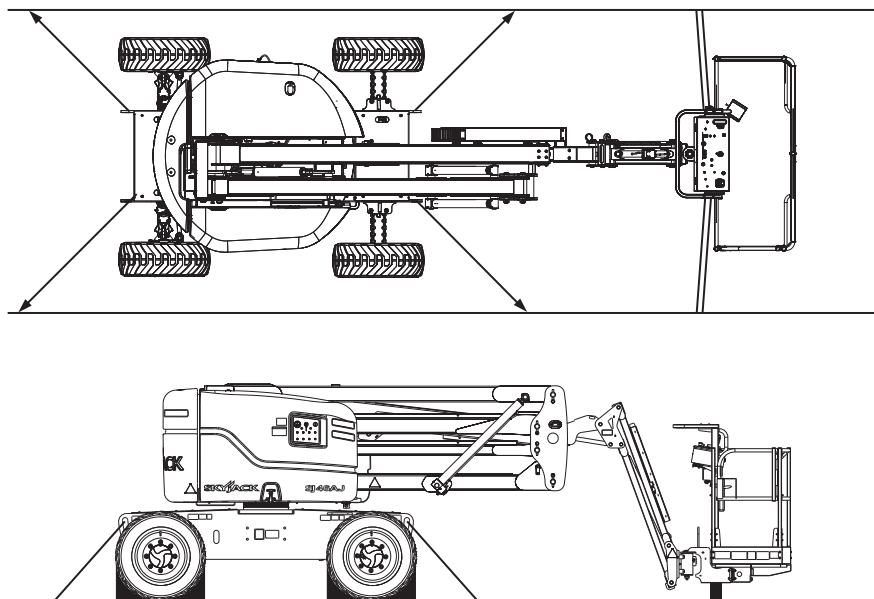

Figure 3-6. Tie-down Points

3.10-2 Locking the Turret

1. Ensure that turret is positioned so that turret transportation lock tube (item 1 - Figure 3-7) is aligned into one of two turret locking points in the turret rotation lock plate.
2. Pull out turret lock retaining pin (item 2 - Figure 3-7). Lower turret lock into locked position and reinsert turret lock retaining pin.



WARNING

Use chains of ample load capacity sufficient to withstand aerial platform weight.

1. Place boom in stowed position centered between drive wheels. Lock turret using turret transportation locking pin (refer to Section 3.10-2) into the transport point (refer to Figure 3-7).
2. Turn main power disconnect switch to “○” off position.
3. Remove all loose items from aerial platform.
4. Properly adjust rigging to prevent damage to aerial platform and so aerial platform remains level.

3.10-3 Lifting

NOTE

When it becomes necessary to lift aerial platform, it is very important that lifting devices are attached only to designated lifting points (refer to Figure 3-8).

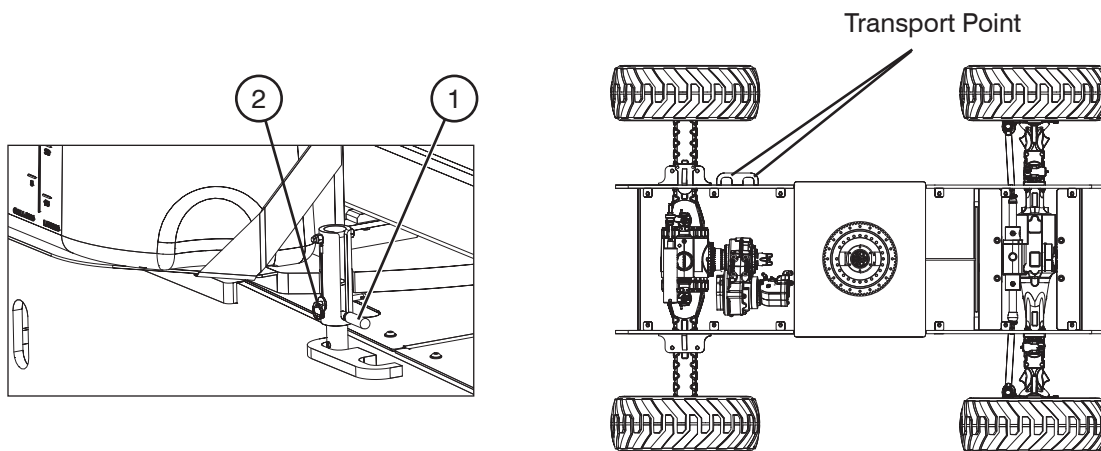

Figure 3-7. Turret Transportation Lock & Locking Points

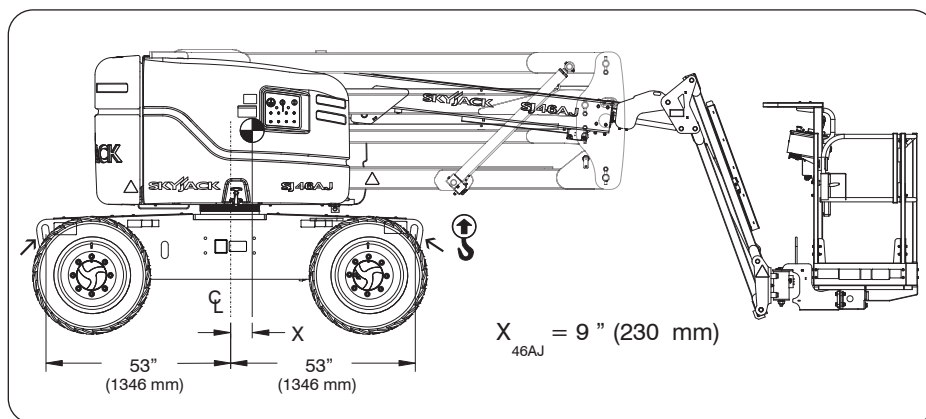

Figure 3-8. Lifting Points
NOTE: Center of gravity varies with different options.

3.11 Chassis Tilt

This section guides the operator with regard to recovering from an inclined position.

IMPORTANT

When the boom is raised or extended, the aerial platform must only be operated on firm level surfaces.



WARNING

When the aerial platform becomes tilted causing the alarm to sound, the platform must be fully lowered and retracted immediately. Drive functions are not available when the tilt alarm is active.

3.11-1 Platform Uphill

If the aerial platform becomes tilted with the platform uphill (refer to [Figure 3-9](#)) follow the steps below to return to a lowered and retracted position.

1. Lower main boom completely.
2. Lower riser completely.
3. Retract fly boom completely.
4. Drive to a firm level surface.

3.11-2 Platform Downhill

If the aerial platform becomes tilted with the platform downhill (refer to [Figure 3-10](#)) follow the steps below to return to a lowered and retracted position.

1. Retract fly boom completely.
2. Lower riser completely.
3. Lower main boom completely.
4. Drive to a firm level surface.

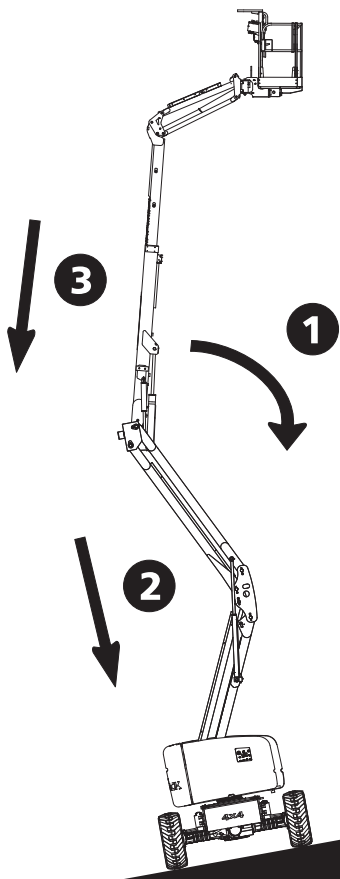

Figure 3-9. Platform Uphill

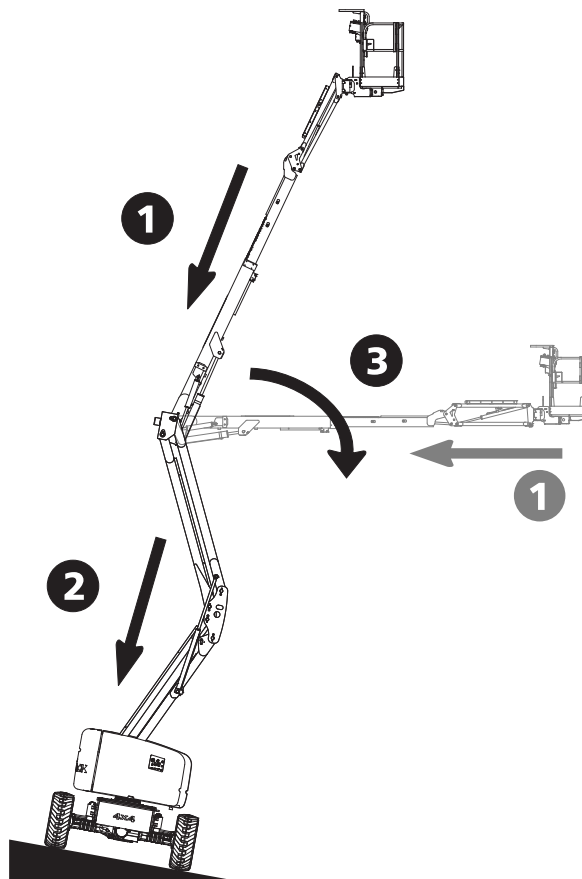

Figure 3-10. Platform Downhill

3.12 Technical Diagrams

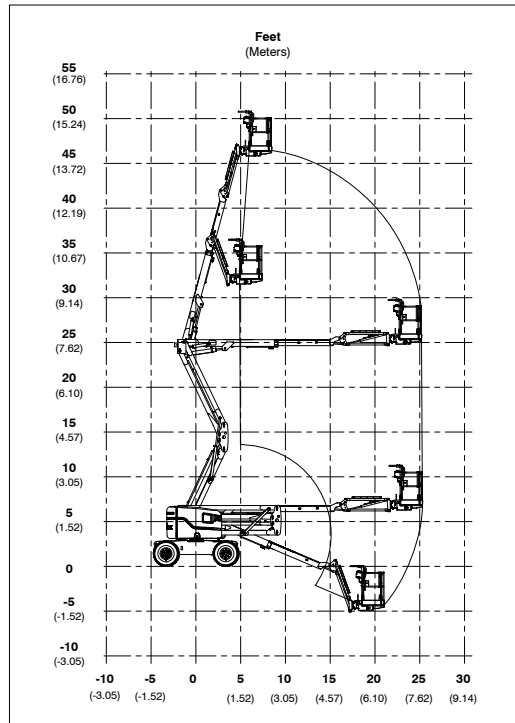

Figure 3-11. Reach Diagram - 46AJ

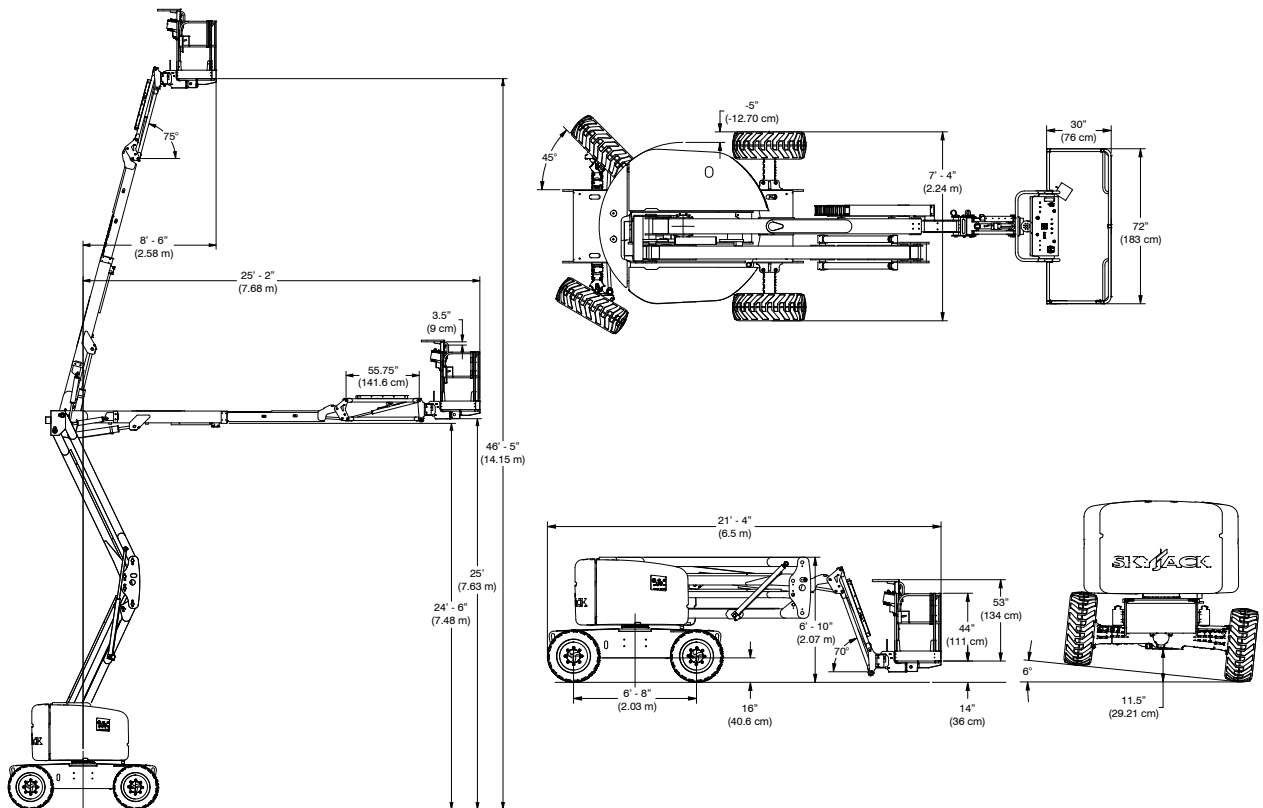
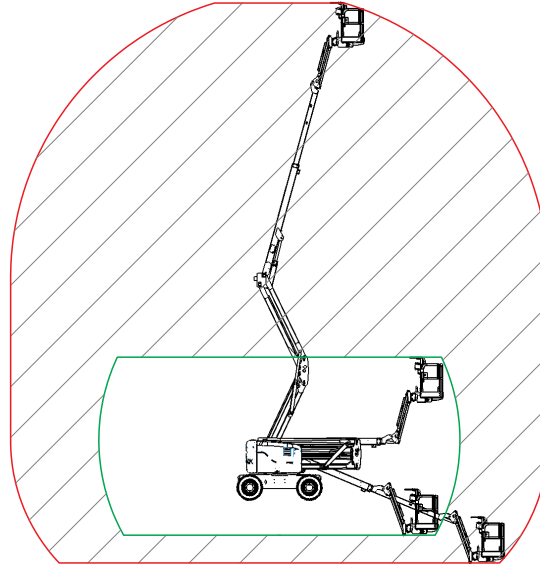

Figure 3-12. Dimension - 46AJ

3.12 Technical Diagrams (Continued)

**WARNING**

Do not raise the platform in work mode if it is not on a firm level surface.





-  Axle oscillation free (travel mode) - drive speed 4.8 mph (7.7 km/h) max.
-  Axle oscillation locked (work mode) - drive speed 0.5 mph (0.8 km/h) max.

Figure 3-13. Axle Oscillation - SJ 46AJ

Table 4.1 Standard and Optional Features

MODEL	SJ 46AJ
STANDARD EQUIPMENT	
12-Volt DC emergency power	✓
5-foot jib	✓
Base controls	✓
Platform controls	✓
Continuous drive and steer directional sensing	✓
Diesel engine	✓
Engine anti-restart protection	✓
Four-wheel drive	✓
Oscillating axle (steer)	✓
Glow plug heaters	✓
Manual brake release	✓
Operator horn	✓
72 x 30 in. (183 X 76 cm) platform (side gate)	✓
Rear entry spring hinged gate	✓
Spring-applied hydraulically released brake	✓
Variable speed drive and function controls	✓
OPTIONAL EQUIPMENT	
3500KW hydraulic generator	✓
Receptacle outlet cable on platform	✓
Air line or hydraulic line to platform	✓
60 x 30 in. (152 x 76 cm) platform (side gate)	✓
All function motion alarm	✓
Foam-filled tires	✓
Catalytic Muffler (Level 1)	✓
Catalytic Muffler (Level 2)	✓
Cold weather start kit (diesel)	✓
Flashing amber light	✓
Platform work light	✓
Welder	✓
Arctic weather package	✓
Positive Air Shutoff	✓

60635AE-ANSI

Table 4.2a Specifications and Features

MODEL		SJ 46AJ
Platform Size	Total platform length (outside)	60 in./ 72 in. (152 cm/ 183 cm)
	Total platform depth (outside)	30 in. (76 cm)
Height	Working	52 ft. 3 in. (15.93 m)
	Platform elevated	46 ft. 3 in. (14.10 m)
	Drive	Driveable at all Heights
	Turret	6 ft. 9 in. (2.06 m)
Length	Overall with platform	20 ft. 10 in. (6.35 m)
	Base and tires	9 ft. 6 in. (2.9 m)
Width	Outside std. tires	7 ft. 6 in. (2.29 m)
	Turret	6 ft. (1.8 m)
Weight	Weight (with air tires)	13,300 lb. (6,033 kg)
	Weight (with foam-filled tires)	14,100 lb. (6,395 kg)
Platform rotation		178 degrees
Horizontal reach		24 ft. 8 in. (7.54 m)
Horizontal reach @ maximum height		8 ft. 1 in. (2.47 m)
Wheelbase		6 ft. 8 in. (2.03 m)
Turret rotation		360 degrees continuous
Turret tailswing		0
Gradeability		45%
Ground clearance between wheels		10.75 in. (0.27 m)
Turning Radius	Inside	4 ft. 11 in. (1.50 m)
	Outside	14 ft. 3 in. (4.34 m)
System Voltage		12V DC
Battery	Type	Lead/Acid
	Cold cranking amperes	950A
Operating Times	Main boom up	23 - 29 seconds (approx.)
	Main boom down	23 - 29 seconds (approx.)
	Riser boom up	23 - 29 seconds (approx.)
	Riser boom down	28 - 34 seconds (approx.)
	Fly boom extend	8 - 14 seconds (approx.)
	Fly boom retract	16 - 21 seconds (approx.)
	Jib up	34 - 44 seconds (approx.)
	Jib down	18 - 28 seconds (approx.)
	Turret rotate - counterclockwise 360° (fully stowed)	68 - 88 seconds (approx.)
Platform rotate - full	15 - 25 seconds (approx.)	
Driving Speeds	Drive speed (maximum-stowed)	4.8 mph (7.7 km/h)
	Drive speed (maximum-elevated)	0.5 mph (0.8 km/h)





122AE-ANSI

Table 4.2b Specifications and Features

MODEL				SJ 46AJ	
Engine - Deutz	Engine Type			Deutz D2.9	Deutz D2011L03i
	Fuel Type			Diesel	
	Fuel Tank Capacity			17 gal. (64 L)	
	Standard Oil Factory Fill	Ambient Temperature Limits	0°F to 115°F (- 18°C to +45°C)	SAE 15W-40 API CF/CG/CH-4	
	Cold Lube Oil Option		- 20°F to 90°F (- 29°C to +32°C)	SAE 5W-30 API CF/CG/CH-4	
	Arctic Lube Oil Option		- 40°F to 115°F (- 40°C to +45°C)	SAE 0W-40 API CF/CG/CH-4	
	Approved Alternates		-	See Engine Manual	
	Lube Oil Sump Capacity			2.11 gal. (8 L)	1.45 gal. (5.5 L)
	Radiator Capacity			2.38 gal (9 L)	N/A
	Radiator Fluid Type			DELO ELC 50/50	N/A
Engine - GM	Engine Type			3.0L GM Dual Fuel	
	Fuel Type - Dual			Gasoline/Propane	
	Fuel Tank Capacity			17 gal. (64 L)	
	Standard Oil Factory Fill	Ambient Temperature Limits	- 40°F to 115°F (- 40°C to +45°C)	SAE 5W-30 API SL	
	Approved Alternates		-	See Engine Manual	
	Lube Oil Capacity			1.19 gal. (4.5 L)	
	Standard Coolant	Ambient Temperature Limits	- 20°F to 115°F (- 29°C to +45°C)	GM 50/50 Extended Life Coolant	
	Arctic Coolant Option		- 40°F to 115°F (- 40°C to +45°C)	GM 60/40 Extended Life Coolant	
Coolant Capacity			3.0 gal. (11.4 L)		
Engine - Kubota	Engine Type			2.5L Kubota Dual Fuel	
	Fuel Type - Dual			Gasoline/Propane	
	Fuel Tank Capacity			45 gal. (170.3 L)	
	Standard Oil Factory Fill	Ambient Temperature Limits	- 40°F to 115°F (- 40°C to +45°C)	SAE 5W-30 API SL	
	Approved Alternates		-	See Engine Manual	
	Lube Oil Capacity			2.5 gal. (9 L)	
	Standard Coolant	Ambient Temperature Limits	- 20°F to 115°F (- 29°C to +45°C)	Recochem 50/50 Extended Life Coolant	
	Arctic Coolant Option		- 40°F to 115°F (- 40°C to +45°C)	Recochem 60/40 Extended Life Coolant	
Coolant Capacity			3.17 gal. (12 L)		
Hydraulic Oil	Recommended Oil	Operating and Oil Temperature Limits	Type	Shell Tellus T46	
			Cold Start	Down to 11°F (-11°C)	
			Ambient Operation	113°F (+45°C)	
	Approved Alternates <i>(Note: Cold weather starting temperatures can be improved with Skyjack options. Please consult your nearest Skyjack service center.)</i>	Hydraulic Tank Capacity	Max. Oil Temp.	200°F(+93°C)	
				Chevron Rykon MV	
				Mobilfluid 424	
			Esso Univis N46		
			24 gal. (91 L)		

123AF-ANSI

Table 4.3 Owner's Annual Inspection Record

										
 Model Number: _____ Serial Number: _____										
*		20__	20__	20__	20__	20__	20__	20__	20__	20__
**										

1000AB

This decal is located on the control compartment cowling. It must be completed after an annual inspection has been completed. Do not use the aerial platform if an inspection has not been recorded in the last 13 months.



	Pictorial	Description
*		Inspection Date
**		Inspector Signature

Table 4.4 Tire/Wheel Specifications

	SJ 46AJ
Tire Size	315/55 D20
Type	Air/Foam-filled
Tire Ply Rating	12
Wheel Nuts Torque	290 ft-lb (393.2 Nm)

60639AB-ANSI

Table 4.5 Maximum Platform Capacities

	SJ 46AJ
Total Capacity *	500 lb. (227 kg)
	2 Persons
Maximum Wind	28 mph (12.5 m/s)
Maximum Side Force	90 lbf (400 N)

60640AB-ANSI

Table 4.6 Floor Loading Pressure

MODEL (with Air Filled Tires)	Gross Aerial Platform Weight		Total Aerial Platform Load					
			Wheel		LCP		OUP	
	lb.	kg	lb.	kg	psi	kPa	psf	kPa
SJ 46AJ	13,800	6,260	7,100	3,220	120	830	200	9.6

MODEL (with Foam Filled Tires)	Gross Aerial Platform Weight		Total Aerial Platform Load					
			Wheel		LCP		OUP	
	lb.	kg	lb.	kg	psi	kPa	psf	kPa
SJ 46AJ	14,600	6,622	7,300	3,315	125	856	210	10.1

60641AC-ANSI

- Gross Aerial Platform Weight = Weight + platform capacity
- LCP – Locally Concentrated Pressure – is a measure of how hard the aerial platform tire tread presses on the area in direct contact with the floor. The floor covering (tile, carpet, etc.) must be able to withstand more than the indicated values above.
- OUP – Overall Uniform Pressure – is a measure of the average load the aerial platform imparts on the whole surface projected directly underneath it. The structure of the operating surface (beams, etc.) must be able to withstand more than the indicated values above.

NOTE:

The LCP or OUP that an individual surface can withstand varies from structure to structure and is generally determined by the engineer or architect for that particular structure.

Locally Concentrated Pressure (LCP):

Foot Print Area identified by test.

$$LCP = \frac{\text{Wheel Load}}{\text{Foot Print Area}}$$

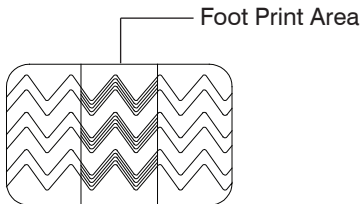
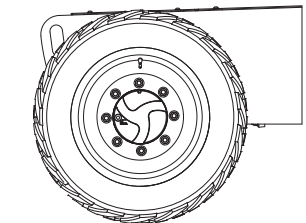

Overall Uniform Pressure (OUP):

Base Area = Length x Width

$$OUP = \frac{\text{Weight of MEWP + Capacity}}{\text{Base Area}}$$

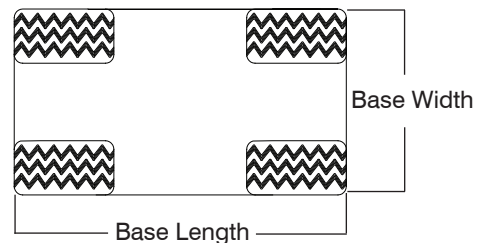
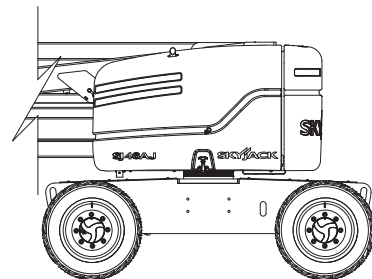

WARNING

Intermixing tires of different types or using tires of types other than those originally supplied with this equipment can adversely affect stability. Therefore, replace tires only with the exact Skyjack-approved type. Failure to operate with matched approved tires in good condition may result in death or serious injury.

General Maintenance

Before attempting any repair work, disconnect battery by turning main power disconnect switch to “○” off position. Preventive maintenance is the easiest and least expensive type of maintenance.

Table 4.7 Maintenance and Inspection Schedule

Frequency	Daily	3 months or 150 hours	Yearly	Frequency	Daily	3 months or 150 hours	Yearly				
Visual and Daily Maintenance Inspections				Boom							
Labels	A	B*†	B*†	Cylinders	A	B*†					
Electrical	A			Wear Pads	A						
Limit Switches	A			Hoses	A						
Hydraulic	A			Power Track	A						
Engine Compartment				Special Options							
Main Power Disconnect Switch	A			Battery Warmer/Hydraulic Oil Heater (If Equipped)	A						
Battery	A			Work Light (If Equipped)	A						
High Pressure Filter	A			Flashing Amber Light (If Equipped)	A						
Hydraulic Pumps	A			Function Tests							
Muffler and Exhaust	A			Test Main Power Disconnect Switch	A			B*†			
Engine Pivot Tray	A			Base Control Console							
Engine Oil Level	A			Test Base Emergency Stop Light	A						
Engine Air Filter	A			Test Base Emergency Stop	A						
Fuel Leaks	A			Test Function Enable Switch & All Boom Functions	A						
Control Compartment											
Base Control Console	A			Test Platform Self-leveling	A						
Hydraulic Tank	A			Test Emergency Power	A						
Hydraulic Oil	A			Test Off/Base/Platform (Base/Off/Platform) Switch	A						
Brake and Main Manifolds	A			Test Positive Air Shutoff (If Equipped)	A						
Emergency Power Unit	A			Platform Control Console							
Fuel Tank	A	Test Platform Emergency Stop Light	A								
Fuel Leaks	A	Test Platform Emergency Stop	A								
Base											
Turret Transportation Lock	A	Test Footswitch	A								
Drive Axle	A	Test Engine Enable Switch	A								
Oscillating Cylinder Assembly	A	Test Steering	A								
Steer Cylinder Assembly	A	Test Driving Function	A								
Tie Rod	A	Test Driving Speed	A								
Wheel/Tire Assembly	A	Test Emergency Power	A								
Manuals											
Platform Assembly	A	Test Horn	A								
Platform Control Console	A	Test Brakes	A								
Rotary Actuator	A	Test Manual Platform Leveling	A								
Jib (If Equipped)	A	Test Differential Lock Switch	A								
		Test Oscillating Axles	A								

60642AD-ANSI

- A** - Perform Visual and Daily Maintenance Inspections & Functions Test. Refer to Section 2.3 and Section 2.4 of this manual.
- B** - Perform Scheduled Maintenance Inspection. Refer to Service & Maintenance manual.
- * - Maintenance must be performed only by trained and competent personnel who are familiar with mechanical procedures.
- † - Refer to Skyjack’s website @ www.skyjack.com for latest service bulletins prior to performing quarterly or yearly inspection.



WARNING

Use original or manufacturer-approved parts and components for aerial platform.

Table 4.8 Operator's Checklist

SKYJACK
OPERATOR'S CHECKLIST

Serial Number: _____
 Model: _____
 Hourmeter Reading: _____
 Date: _____
 Time: _____

Operator's Name (Printed): _____

Operator's Signature: _____

Each item shall be inspected using the appropriate section of the Skyjack operating manual. As each item is inspected, check the appropriate box.

- P** - PASS
- F** - FAIL
- R** - REPAIRED
- NA** - NOT APPLICABLE

INSPECTION FREQUENCY

- DAILY
- FREQUENTLY
- ANNUALLY
- BI-ANNUALLY

	NA	P	F	R
Visual and Daily Maintenance Inspections				
Labels				
Electrical				
Limit Switches				
Hydraulic				
Engine Compartment				
Main Power Disconnect Switch				
Battery				
High Pressure Filter				
Hydraulic Pumps				
Muffler and Exhaust				
Engine Pivot Tray				
Engine Oil Level				
Engine Air Filter				
Fuel Leaks				
Control Compartment				
Base Control Console				
Hydraulic Tank				
Hydraulic Oil				
Brake and Main Manifolds				
Emergency Power Unit				
Fuel Tank				
Fuel Leaks				
Base				
Turret Transportation Lock				
Drive Axle				
Oscillating Cylinder Assembly				
Steer Cylinder Assembly				
Tie Rod				
Wheel/Tire Assembly				
Manuals				
Platform Assembly				
Platform Control Console				
Rotary Actuator				
Jib (If Equipped)				

	NA	P	F	R
Boom				
Cylinders				
Wear Pads				
Hoses				
Power Track				
Special Options				
Battery Warmer/Hydraulic Oil Heater (If Equipped)				
Work Light (If Equipped)				
Flashing Amber Light (If Equipped)				
Function Tests				
Test Main Power Disconnect Switch				
Base Control Console				
Test Base Emergency Stop Light				
Test Base Emergency Stop				
Test Function Enable Switch & All Boom Functions				
Test Platform Self-leveling				
Test Emergency Power				
Test Off/Base/Platform (Base/Off/Platform) Switch				
Test Positive Air Shutoff (If Equipped)				
Platform Control Console				
Test Platform Emergency Stop Light				
Test Platform Emergency Stop				
Test Footswitch				
Test Engine Enable Switch				
Test Steering				
Test Driving Function				
Test Driving Speed				
Test Emergency Power				
Test Horn				
Test Brakes				
Test Brakes				
Test Manual Platform Leveling				
Test Differential Lock Switch				
Test Oscillating Axles				

60643AD-ANSI

Note:
Make a copy of this page or visit the Skyjack web site:

Label Legend



A red horizontal bar at the top contains a warning triangle icon and an open book icon. Below the bar, the text reads "Safety Red indicates DANGER." An arrow points from the text "Safety Red" to the right side of the red bar.



An orange horizontal bar at the top contains a warning triangle icon and an open book icon. Below the bar, the text reads "Safety Orange indicates WARNING." An arrow points from the text "Safety Orange" to the right side of the orange bar.

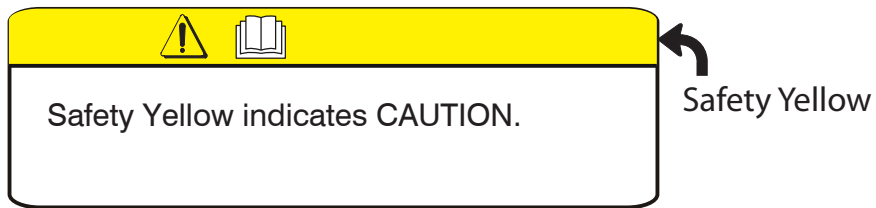

A yellow horizontal bar at the top contains a warning triangle icon and an open book icon. Below the bar, the text reads "Safety Yellow indicates CAUTION." An arrow points from the text "Safety Yellow" to the right side of the yellow bar.

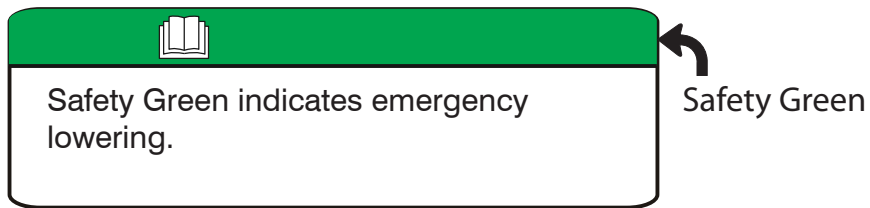

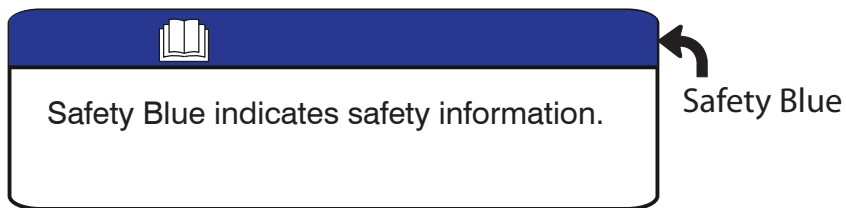

A green horizontal bar at the top contains an open book icon. Below the bar, the text reads "Safety Green indicates emergency lowering." An arrow points from the text "Safety Green" to the right side of the green bar.



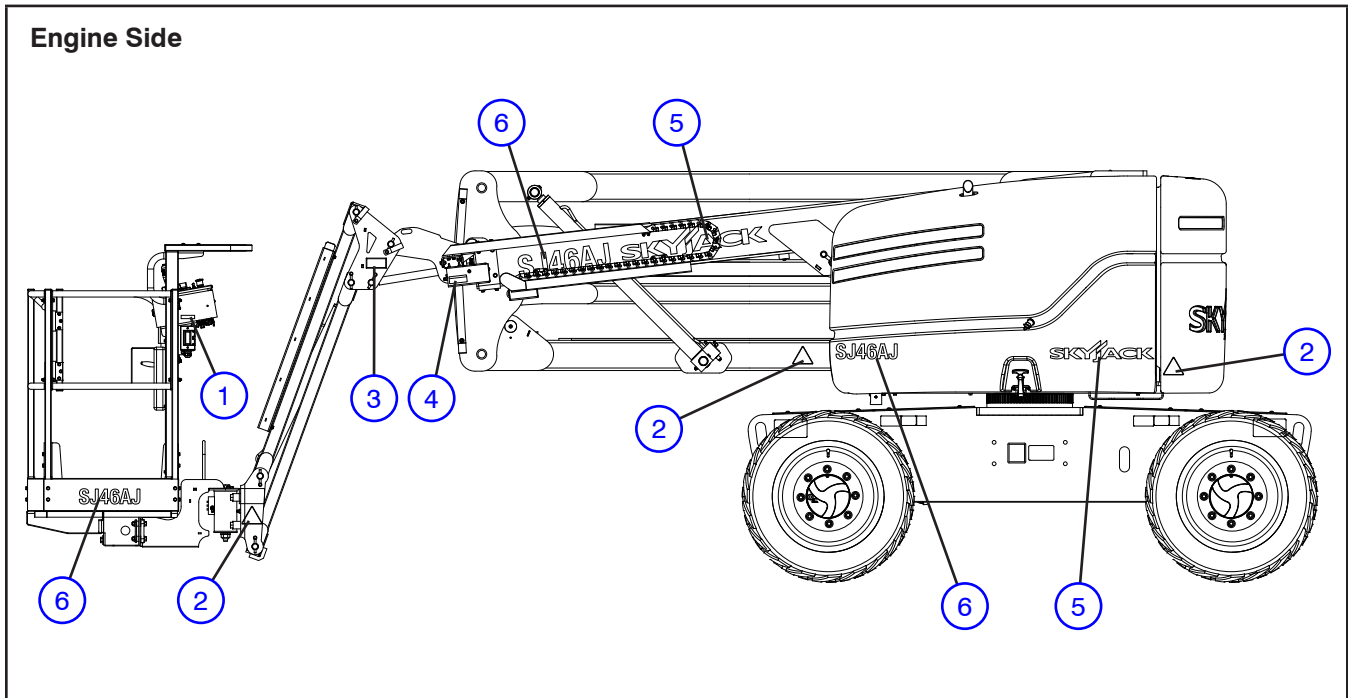

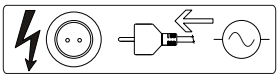
A blue horizontal bar at the top contains an open book icon. Below the bar, the text reads "Safety Blue indicates safety information." An arrow points from the text "Safety Blue" to the right side of the blue bar.

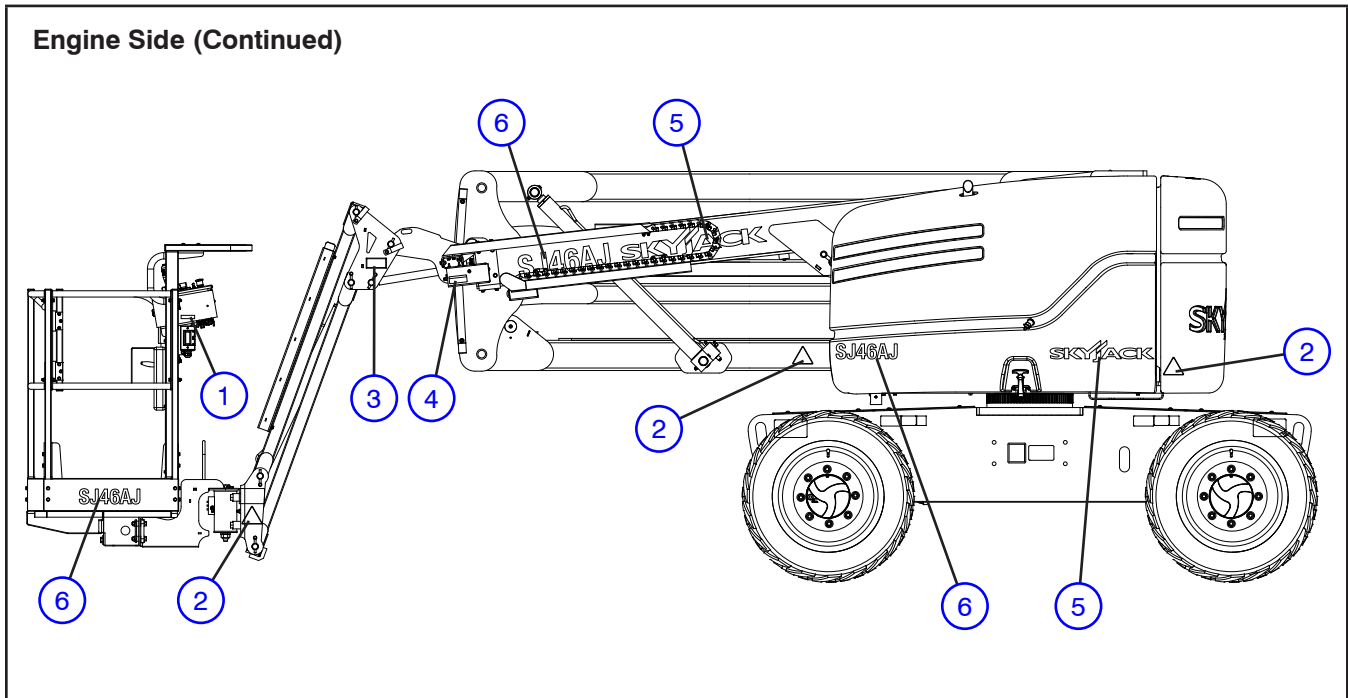

No.	Label Pictorial	Description
1		<p>Connect AC Supply Connect AC supply here.</p>
2		<p>Body Crushing Hazard Danger - Body crushing hazard</p>
3		<p>Crushing Hazard Danger - Crushing hazard</p>



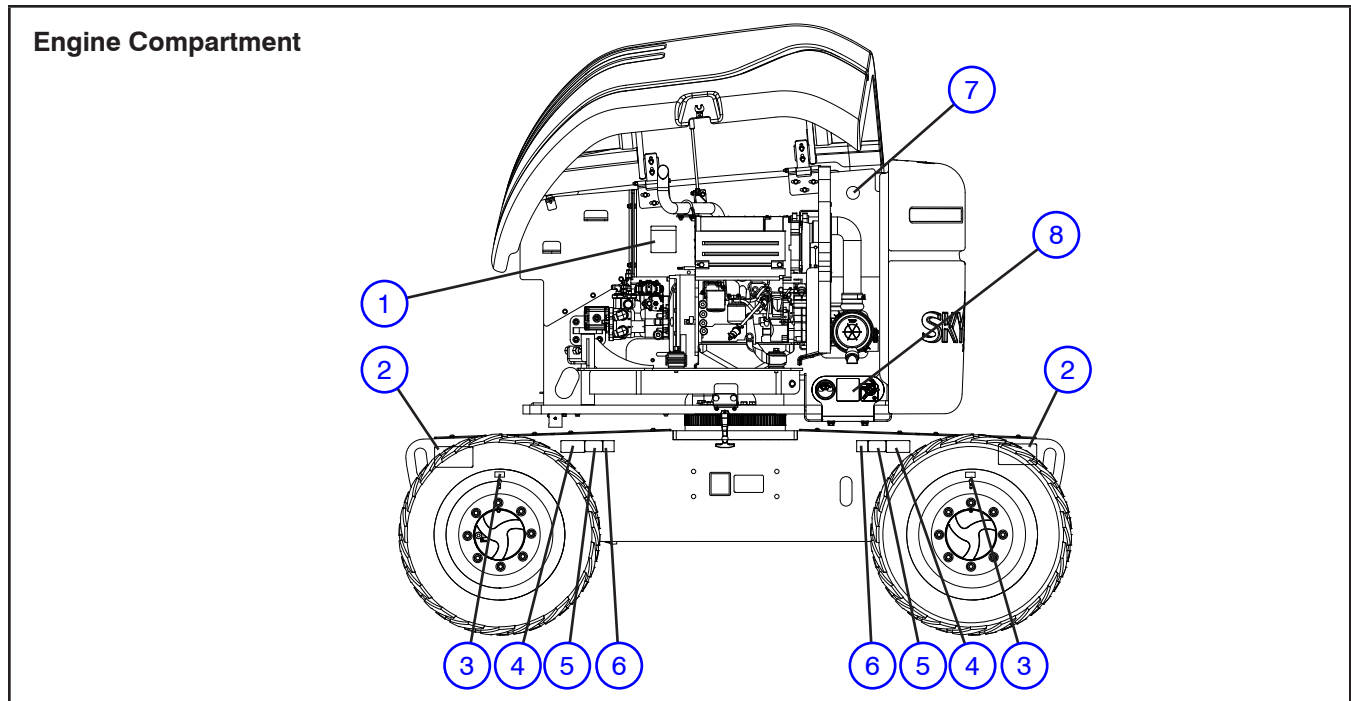

No.	Label Pictorial	Description
4		<p>Warning - Do Not Alter</p> <p>Do not alter or disable limit switches or other safety devices.</p>
5		<p>Skyjack Logo</p> <p>Skyjack</p>
6		<p>Model Number*</p> <p>Product Identifier *Model number will vary, may not be as shown.</p>



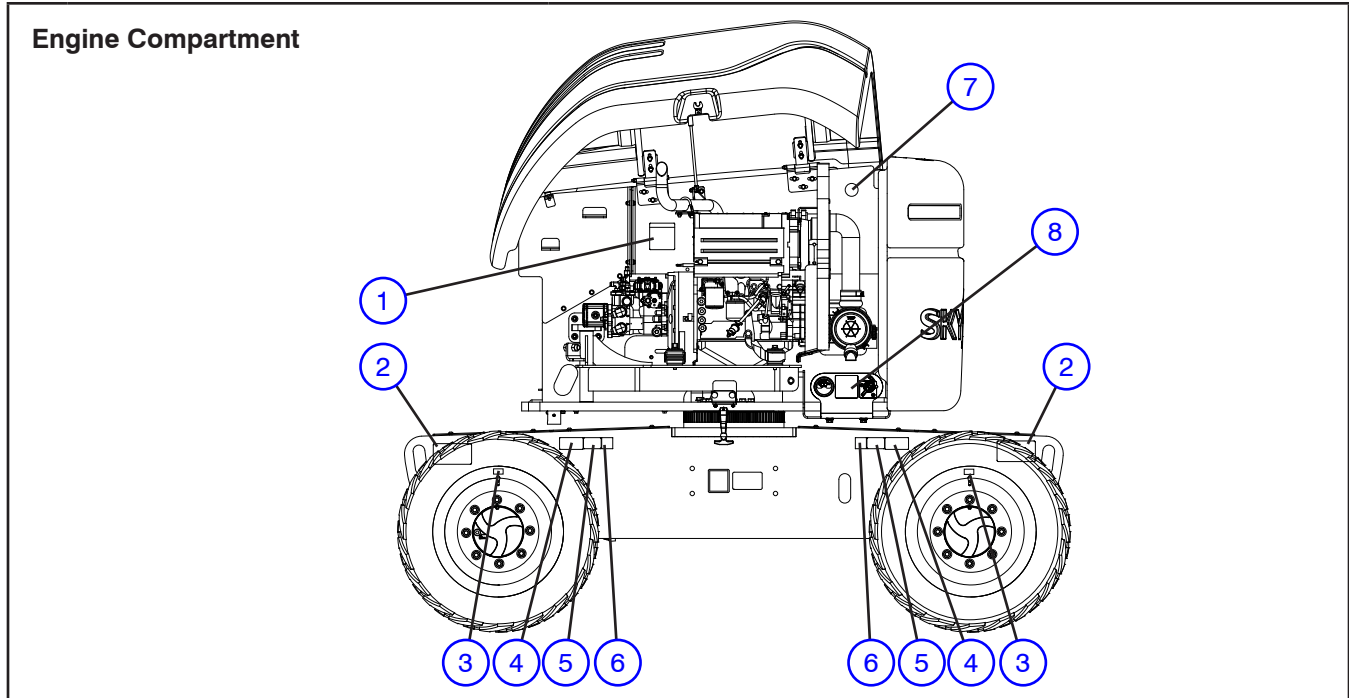

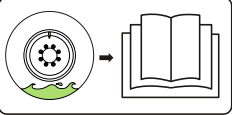

No.	Label Pictorial	Description
1		<p>Winching/Towing/Pushing Procedure Refer to Operating manual.</p> <ol style="list-style-type: none"> 1. Block or chock wheels to prevent aerial platform from rolling. 2. Turn main power disconnect switch to off position. At engine side: 3. Locate bypass valve (marked with yellow colour) on inboard side of drive pump. 4. Rotate bypass valve flat using pliers or 1/4" (7mm) wrench by 90 degrees (clockwise). At hydraulic tank side: 5. Locate brake valve and pump. 6. Push in black knob. 7. Pump by pushing red knob in and out until firm resistance is felt or until 300 psi/21 bar shows on the gauge (if equipped). Brake is now released. 8. A) Remove blocks from wheels. B) Push/tow/winch to desired location. 9. Block or chock wheels to prevent aerial platform from rolling. At hydraulic tank side: 10. Reset brake by pulling out black knob. At engine side: 11. Close bypass valve by rotating 90 degrees (counterclockwise) to normal condition (flat is parallel to shaft axis). <p style="text-align: center;">NOTE Before operation, ensure all blocks are removed from wheels.</p>

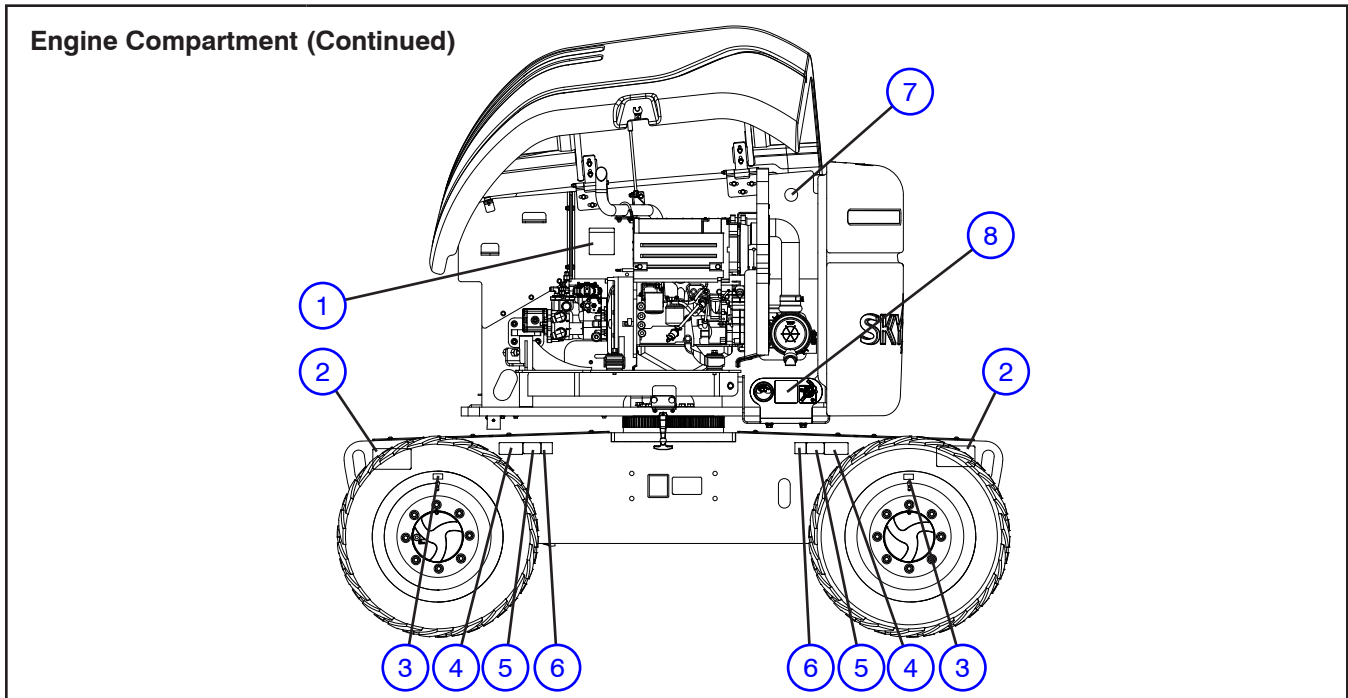

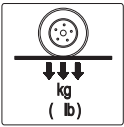
No.	Label Pictorial	Description
2		<p>Lift and Tie Down Points</p> <p>Only use these points for lifting or tying down.</p>
3		<p>Tire Sealant (If Equipped)</p> <p>Indicates that tire sealant is present inside the tires.</p>
4		<p>Wheel Specifications</p> <p>Refer to manual for wheel type, offset, pressure and torque.</p>



No.	Label Pictorial	Description
5		<p>Wheel Load*</p> <p>Indicates rated wheel load. *Wheel load will vary over different aerial platforms.</p>
6		<p>Tire Pressure*</p> <p>Indicates rated tire pressure. *Tire pressure will vary, may not be as shown.</p> <p>Foam-filled Tire (If Equipped)</p> <p>Indicates foam-filled tire.</p>
7		<p>Warning - Do Not Alter</p> <p>Do not alter or disable limit switches or other safety devices.</p>
8		<p>Main Power Disconnect</p> <p>Main power disconnect switch</p>

Rear Side - Base

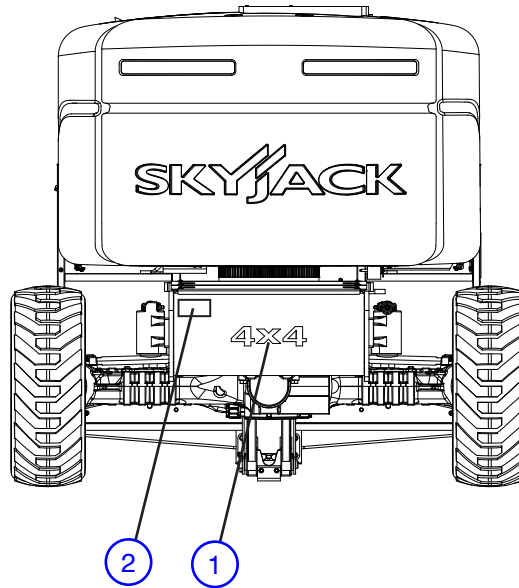

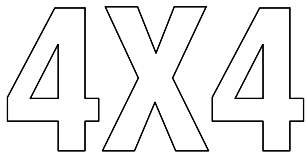
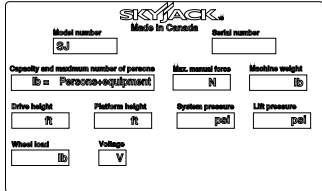

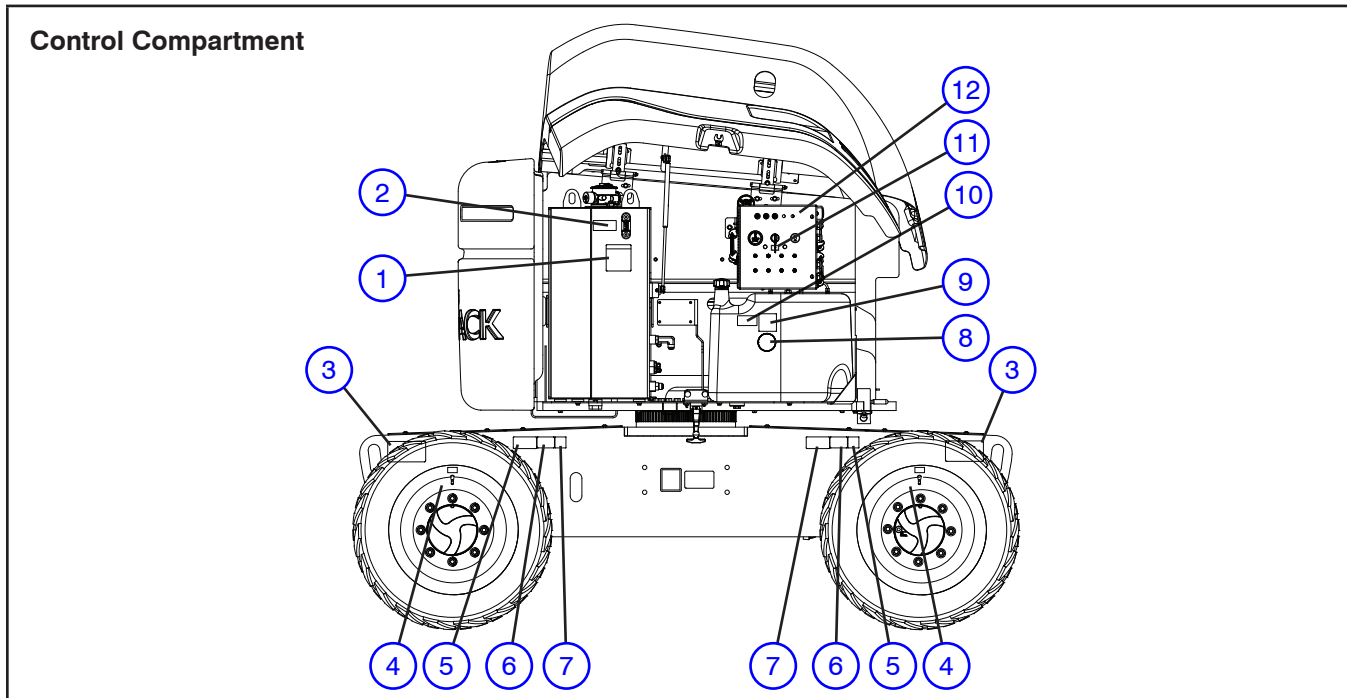

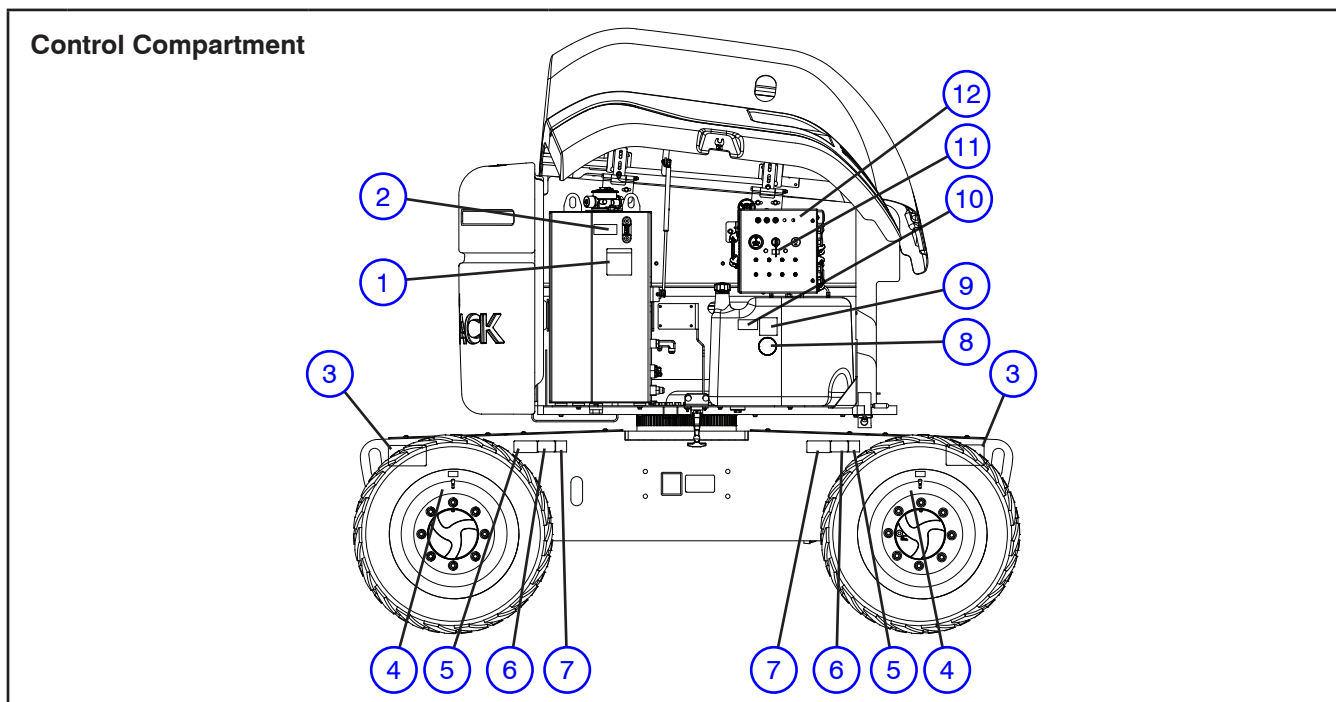

No.	Label Pictorial	Description
1		<p>4x4 (If Equipped)</p> <p>Product identifier - 4 wheel drive</p>
2		<p>Serial Plate*</p> <p>Product identification and specifications *Serial plates will vary, may not be as shown.</p>

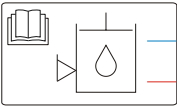

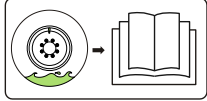

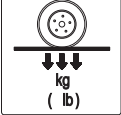

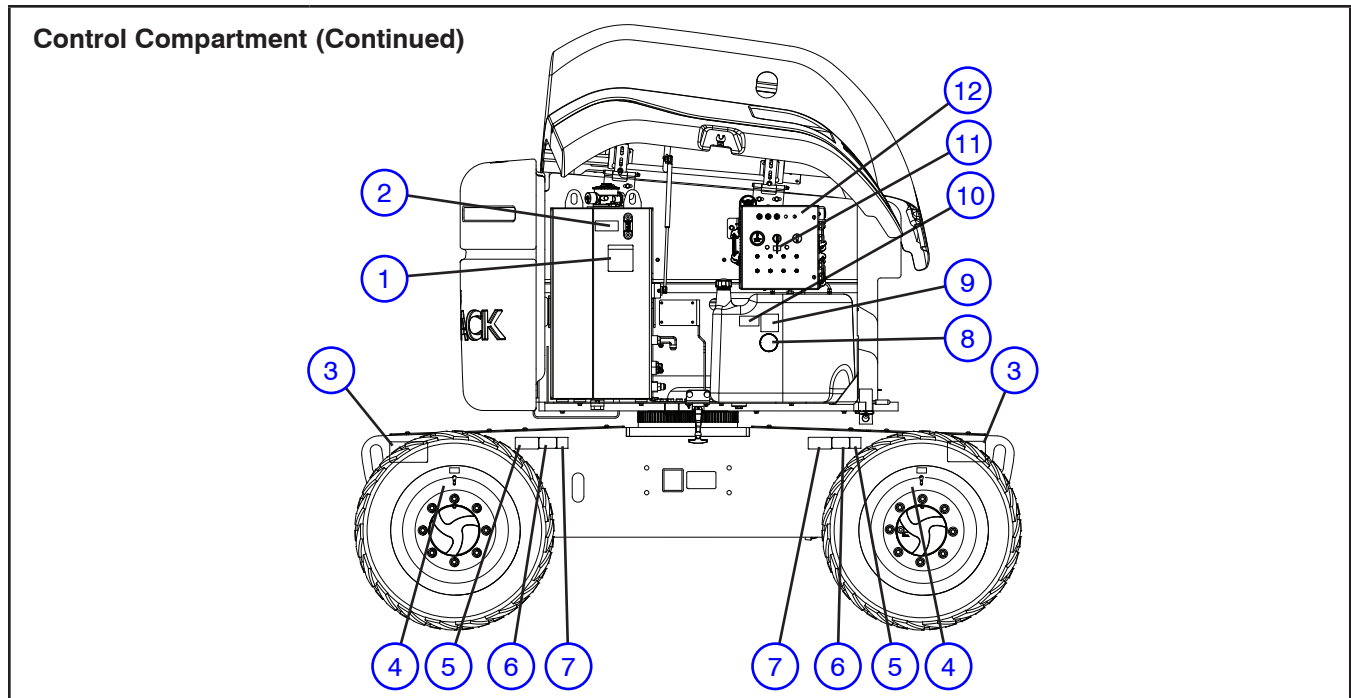

No.	Label Pictorial	Description
1	<p>The pictorial diagram consists of 12 numbered steps: 1. Block or chock wheels. 2. Turn main power disconnect switch to off. 3. Locate bypass valve. 4. Rotate bypass valve flat. 5. Locate brake valve and pump. 6. Push in black knob. 7. Pump by pushing red knob. 8. A) Remove blocks from wheels. B) Push/tow/win. 9. Block or chock wheels. 10. Reset brake by pulling out black knob. 11. Close bypass valve. 12. (Not explicitly shown in pictorial but implied by text).</p>	<p>Winching/Towing/Pushing Procedure Refer to Operating manual.</p> <ol style="list-style-type: none"> Block or chock wheels to prevent aerial platform from rolling. Turn main power disconnect switch to off position. At engine side: Locate bypass valve (marked with yellow colour) on inboard side of drive pump. Rotate bypass valve flat using pliers or 1/4" (7mm) wrench by 90 degrees (clockwise). At hydraulic tank side: Locate brake valve and pump. Push in black knob. Pump by pushing red knob in and out until firm resistance is felt or until 300 psi/21 bar shows on the gauge (if equipped). Brake is now released. A) Remove blocks from wheels. B) Push/tow/win to desired location. Block or chock wheels to prevent aerial platform from rolling. At hydraulic tank side: Reset brake by pulling out black knob. At engine side: Close bypass valve by rotating 90 degrees (counterclockwise) to normal condition (flat is parallel to shaft axis). <p style="text-align: center;">NOTE Before operation, ensure all blocks are removed from wheels.</p>



No.	Label Pictorial	Description
2		<p>Hydraulic Oil Level Indicates minimum/maximum oil level.</p>
3		<p>Lift and Tie Down Points Only use these points for lifting or tying down.</p>
4		<p>Tire Sealant (If Equipped) Indicates that tire sealant is present inside the tires.</p>
5		<p>Wheel Specifications Refer to manual for wheel type, offset, pressure and torque.</p>
6		<p>Wheel Load* Indicates rated wheel load. *Wheel load will vary over different aerial platforms.</p>
7		<p>Tire Pressure* Indicates rated tire pressure. *Tire pressure will vary, may not be as shown.</p> <p>Foam-filled Tire (If Equipped) Indicates foam-filled tire.</p>



No.	Label Pictorial	Description
8		<p>No Smoking Do not smoke near this location.</p>
9		<p>Diesel Ultra Low Sulfur Only Diesel Ultra Low Sulfur Only</p>
		<p>Diesel Use diesel fuel only.</p>
		<p>Unleaded Fuel Use unleaded gasoline only.</p>
10		<p>Open Fuel Cap Slowly Refer to Operating manual. Open fuel cap slowly to prevent fuel from spraying out of fuel tank.</p>
11		<p>Positive Air Shutoff (If Equipped) Use this switch to trigger the positive air shutoff valve.</p>

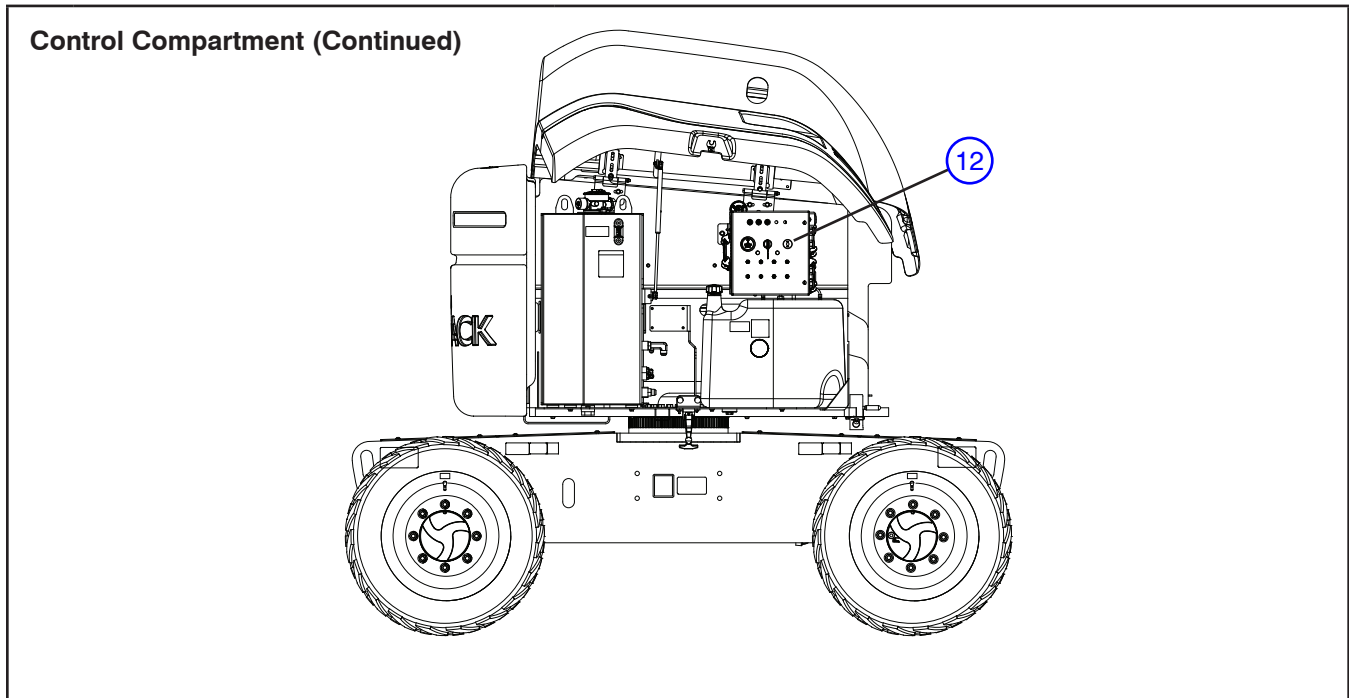

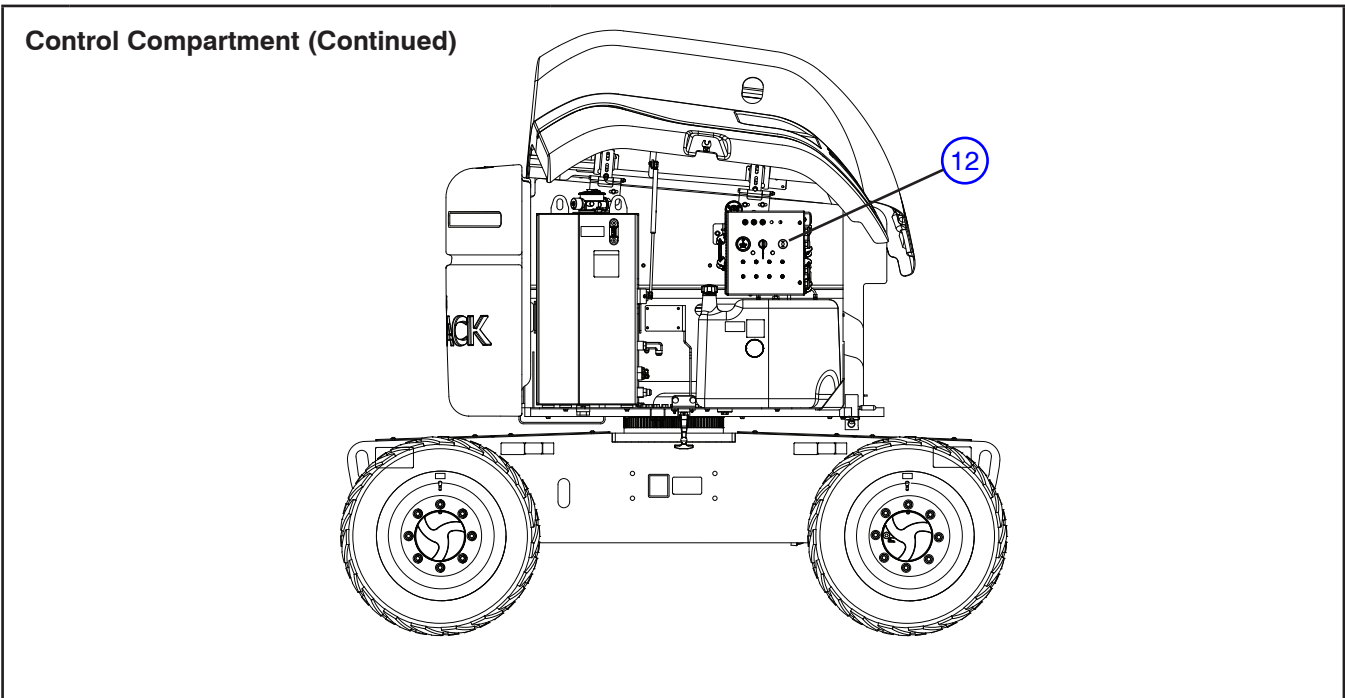

No.	Label Pictorial	Description
12a		<p>Base Control Console</p> <p>Push “” breaker back in to reset.</p> <p>Read “” operating manual.</p> <p>Select “” to turn engine off, “” to enable base control console or “” to enable platform control console.</p> <p>Push “” emergency stop to stop engine and disable controls.</p> <p>Select “” to extend fly boom or “” to retract fly boom.</p> <p>Select “” to rotate platform to the left or “” to rotate to the right.</p> <p>Select “” to tilt platform up or “” to tilt platform down.</p> <p>Select “” to move jib up or “” to move jib down.</p> <p>Select “” to rotate turret to the left or “” to rotate to the right.</p> <p>Select “” to raise riser or “” to lower riser.</p> <p>Select “” to raise main boom or “” to lower main boom.</p> <p>Push and hold “” to start engine, “” to enable base control functions or “” to enable the emergency power unit.</p>



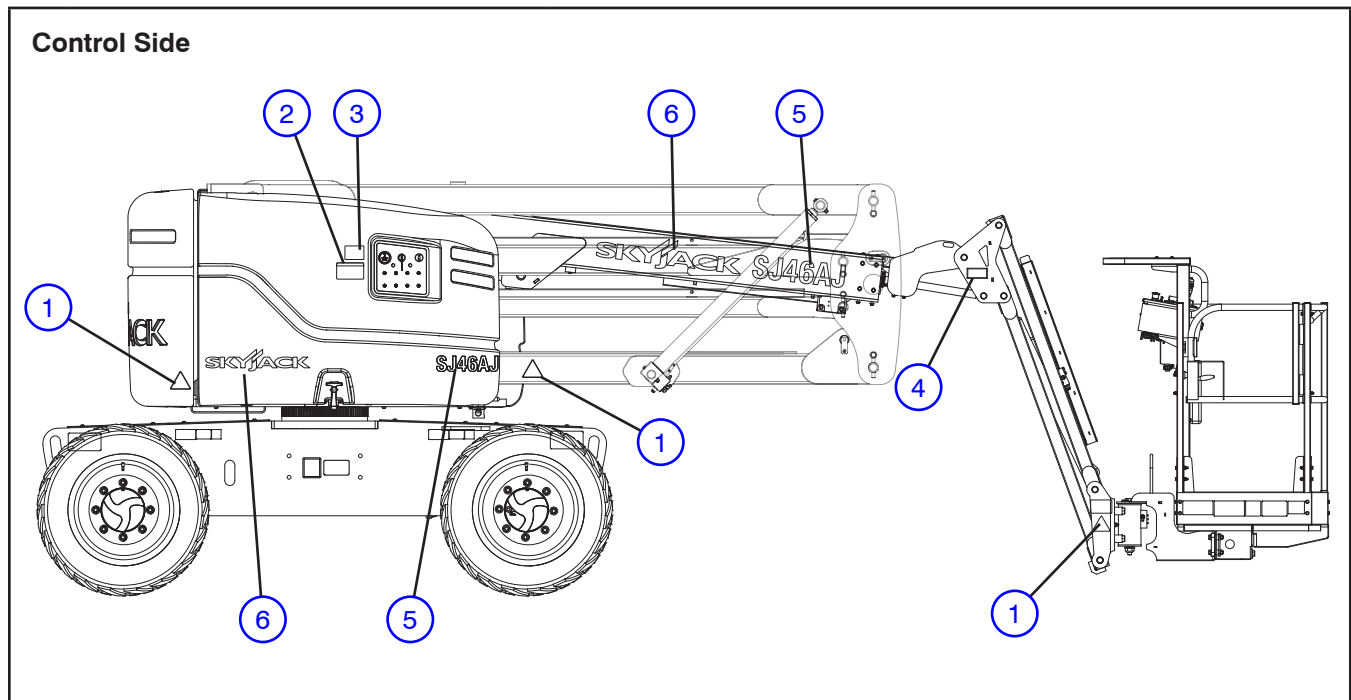

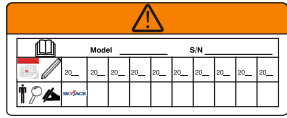
No.	Label Pictorial	Description
12b		<p>Base Control Console</p> <p>Push “” breaker back in to reset.</p> <p>Read “” operating manual.</p> <p>Select “” to enable base control console, “” to turn engine off or “” to enable platform control console.</p> <p>Push “” emergency stop to stop engine and disable controls.</p> <p>Select “” to extend fly boom or “” to retract fly boom.</p> <p>Select “” to rotate platform to the left or “” to rotate to the right.</p> <p>Select “” to tilt platform up or “” to tilt platform down.</p> <p>Select “” to move jib up or “” to move jib down.</p> <p>Select “” to rotate turret to the left or “” to rotate to the right.</p> <p>Select “” to raise riser or “” to lower riser.</p> <p>Select “” to raise main boom or “” to lower main boom.</p> <p>Push and hold “” to start engine or “” to enable the emergency power unit.</p> <p>Push and hold “” in either direction to enable base control functions.</p>



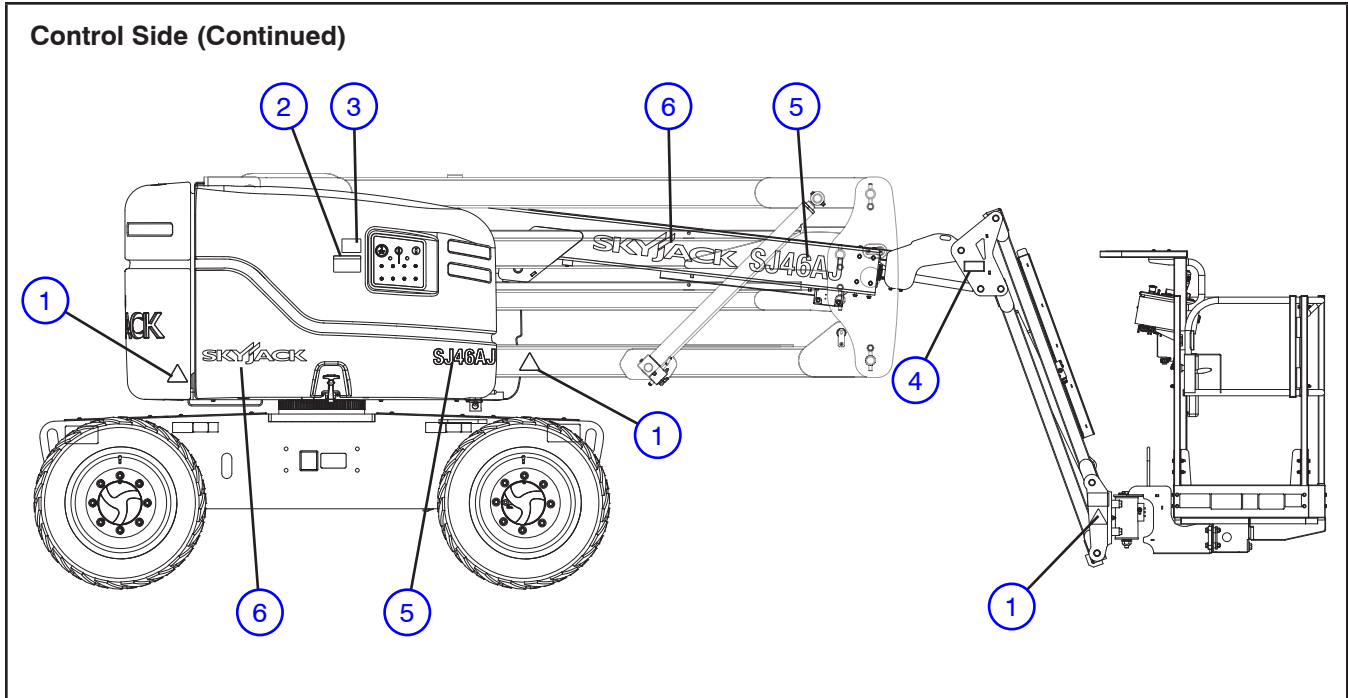



No.	Label Pictorial	Description
1		<p>Body Crushing Hazard</p> <p>Danger - Body crushing hazard</p>
2		<p>Annual Inspection</p> <p>Ensure that work platform has received annual inspection prior to operation.</p>
3		<p>Emergency Lowering Procedure</p> <p>In case of emergency, follow procedure outlined in label to lower the platform.</p>

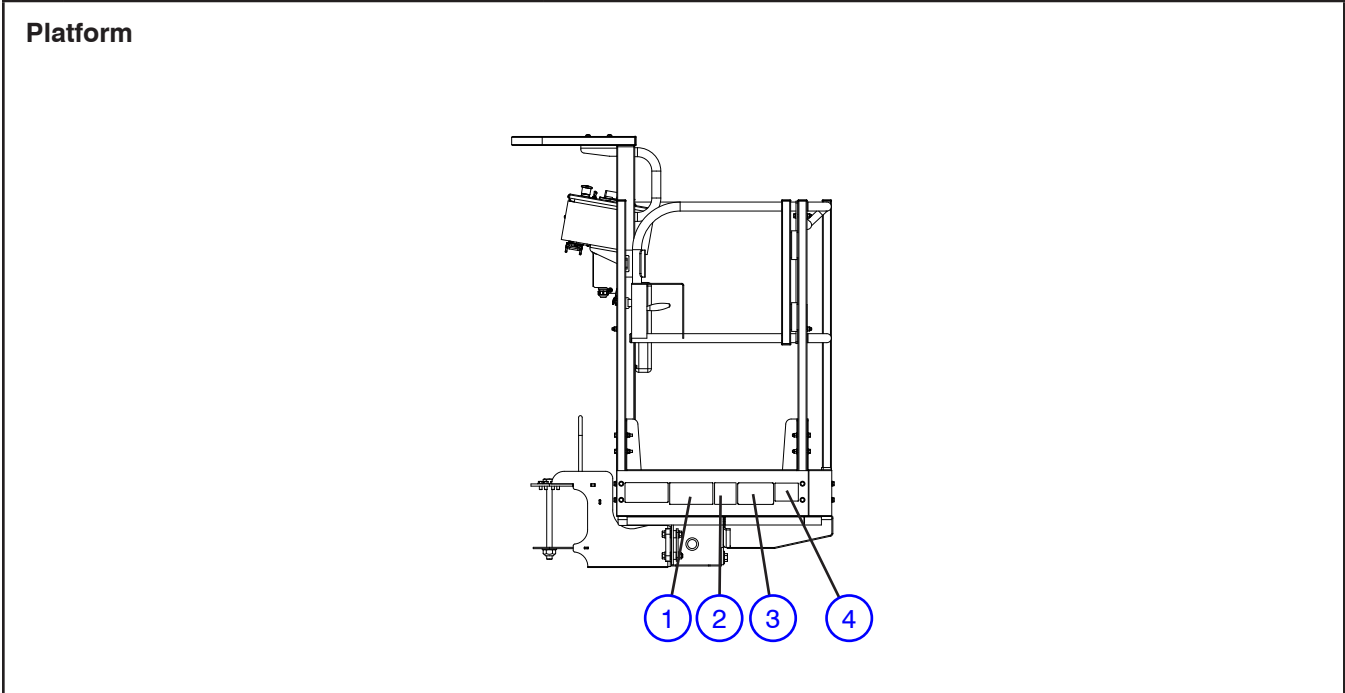

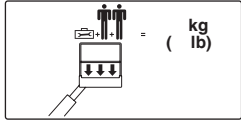

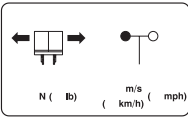
No.	Label Pictorial	Description
4		<p>Crushing Hazard Danger - Crushing hazard</p>
5	<p>SJ46AJ</p>	<p>Model Number* Product Identifier *Model number will vary, may not be as shown.</p>
6		<p>Skyjack Logo Skyjack</p>

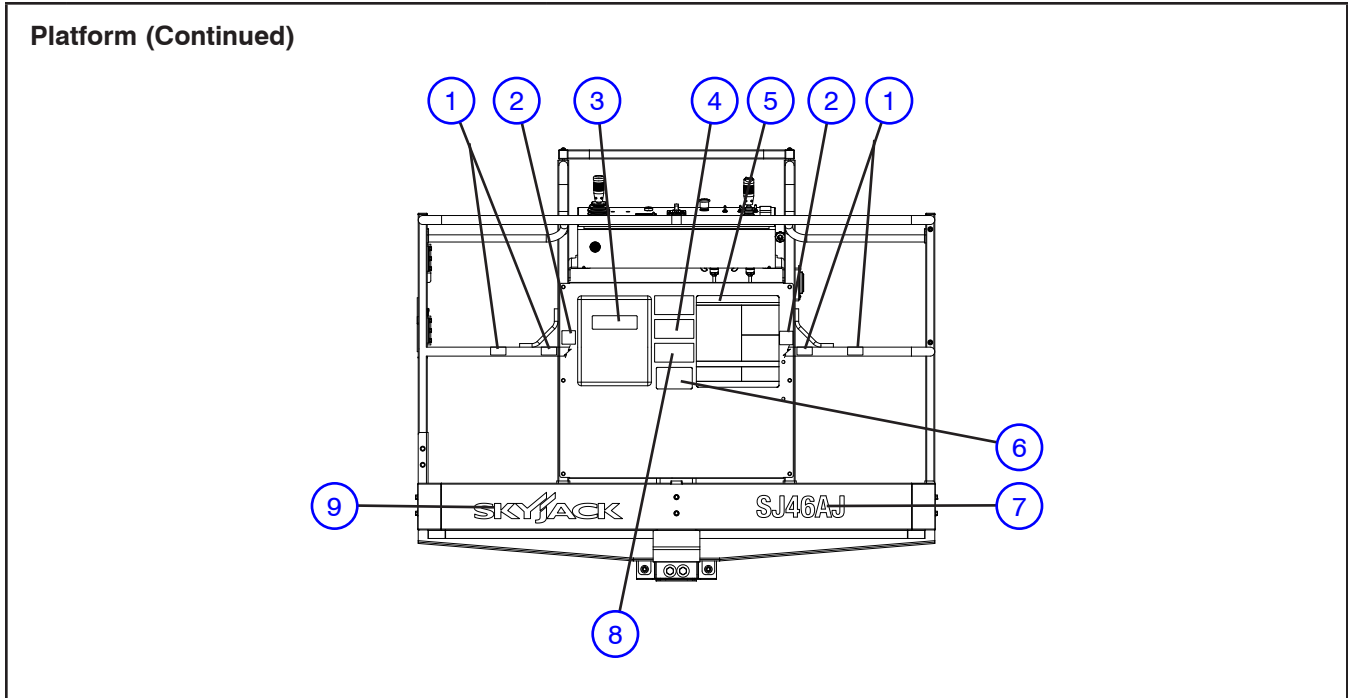

No.	Label Pictorial	Description
1		<p>Platform Capacity*</p> <p>Rated work load when operating on a level ground. Rated work load includes the weight of both personnel and material, and maximum number of people in each configuration. Do not exceed total weight or maximum number of people. Load platform uniformly.</p> <p>*Platform capacity will vary over different aerial platforms.</p>
2		<p>Operator's Daily Inspection.</p> <p>Refer to the Operating manual. Perform visual inspection and function tests at the beginning of each shift. Refer to Table 4.7 Maintenance and Inspection Schedule.</p>
3		<p>Horizontal Load Rating</p> <p>Apply no more than indicated side load. Operate below indicated wind speed only.</p>
4		<p>No Jewelry</p> <p>Caution - Do not wear jewelry.</p>

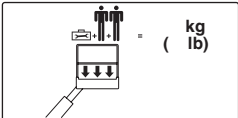

No.	Label Pictorial	Description
1		<p>Warning - No Step</p> <p>No step warning</p>
2		<p>Fall Protection Anchorage</p> <p>Attach body harness lanyards of each occupant to fall protection anchorage points. Rated for one (1) person per anchorage.</p>
3		<p>Manual Box</p> <p>Indicates location of operating manual.</p>
4		<p>Platform Capacity*</p> <p>Rated work load when operating on a level ground. Rated work load includes the weight of both personnel and material, and maximum number of people in each configuration. Do not exceed total weight or maximum number of people. Load platform uniformly.</p> <p>*Platform capacity will vary over different aerial platforms.</p>

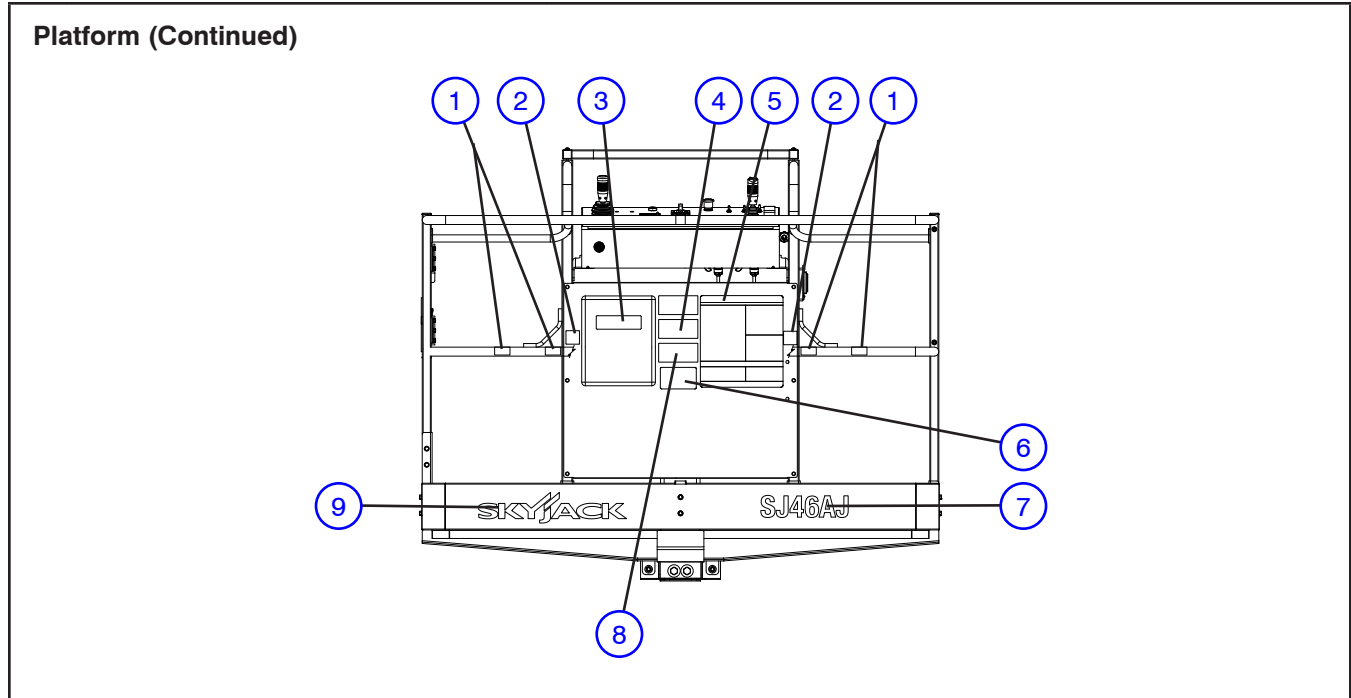

No.	Label Pictorial	Description
5		<p>Hazard Identification</p> <p>Refer to Section 1: Safety Rules. Read and understand outlined risks associated with this work platform prior to operation.</p>
6		<p>AWPT “Click It!” (ANSI/CSA)</p> <p>Indicates full body harness awareness.</p>
7		<p>Model Number*</p> <p>Product Identifier *Model number will vary, may not be as shown.</p>
8		<p>Horizontal Load Rating</p> <p>Apply no more than indicated side load. Operate below indicated wind speed only.</p>
9		<p>Skyjack Logo</p> <p>Skyjack</p>

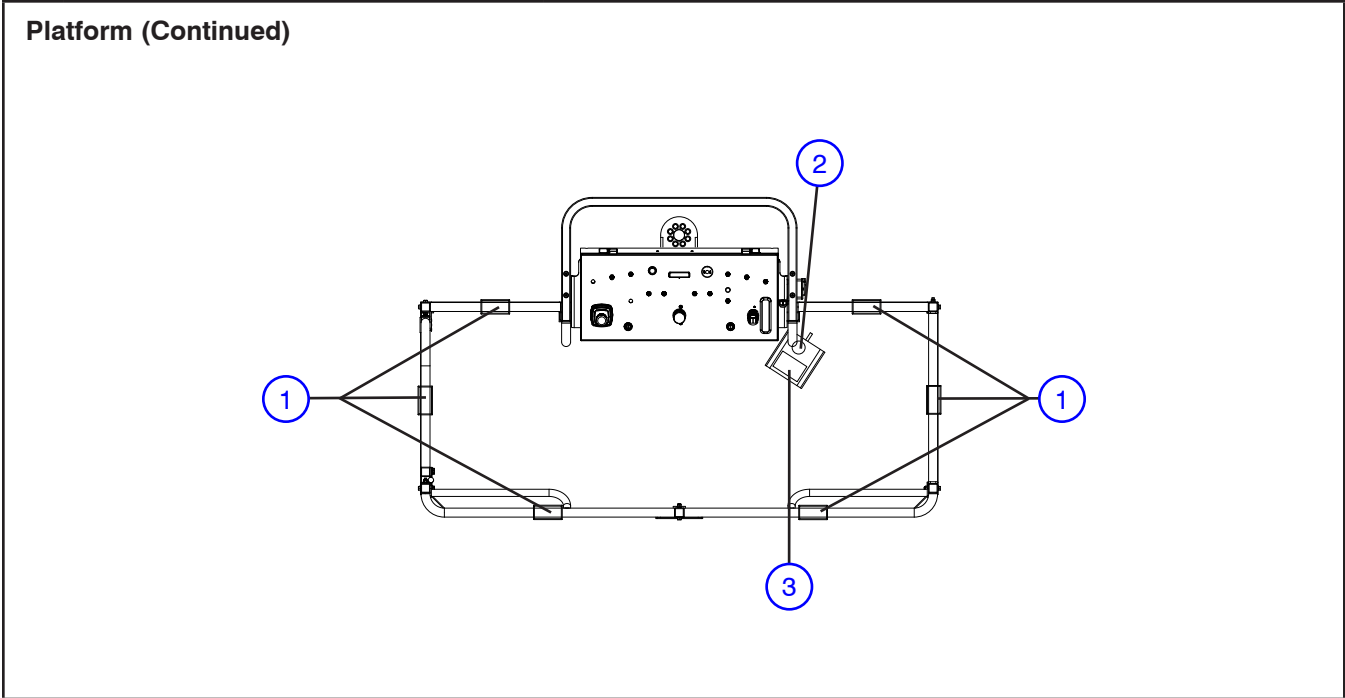

No.	Label Pictorial	Description
1		<p>Crushing Hazard Danger - Crushing hazard</p>
2		<p>Warning - Do Not Alter Do not alter or disable limit switches or other safety devices.</p>
3		<p>Footswitch Enable (On/Off) Depress and hold footswitch to enable platform function.</p>

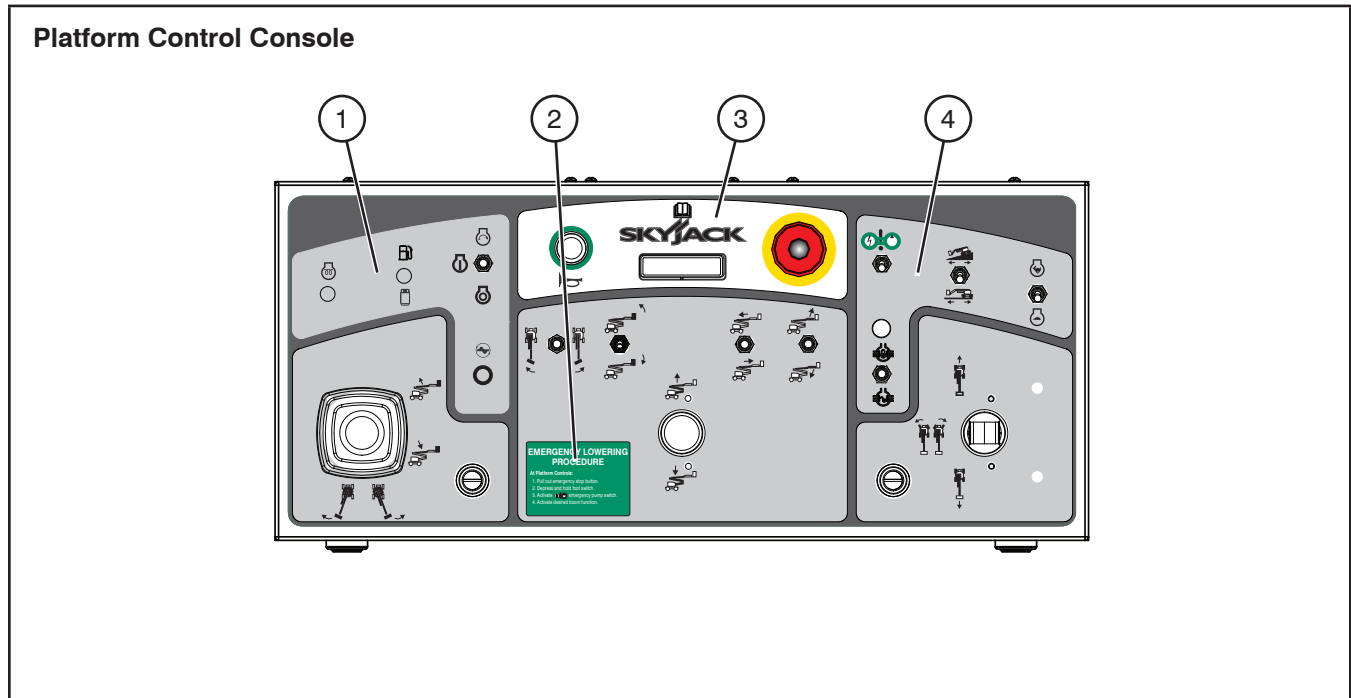

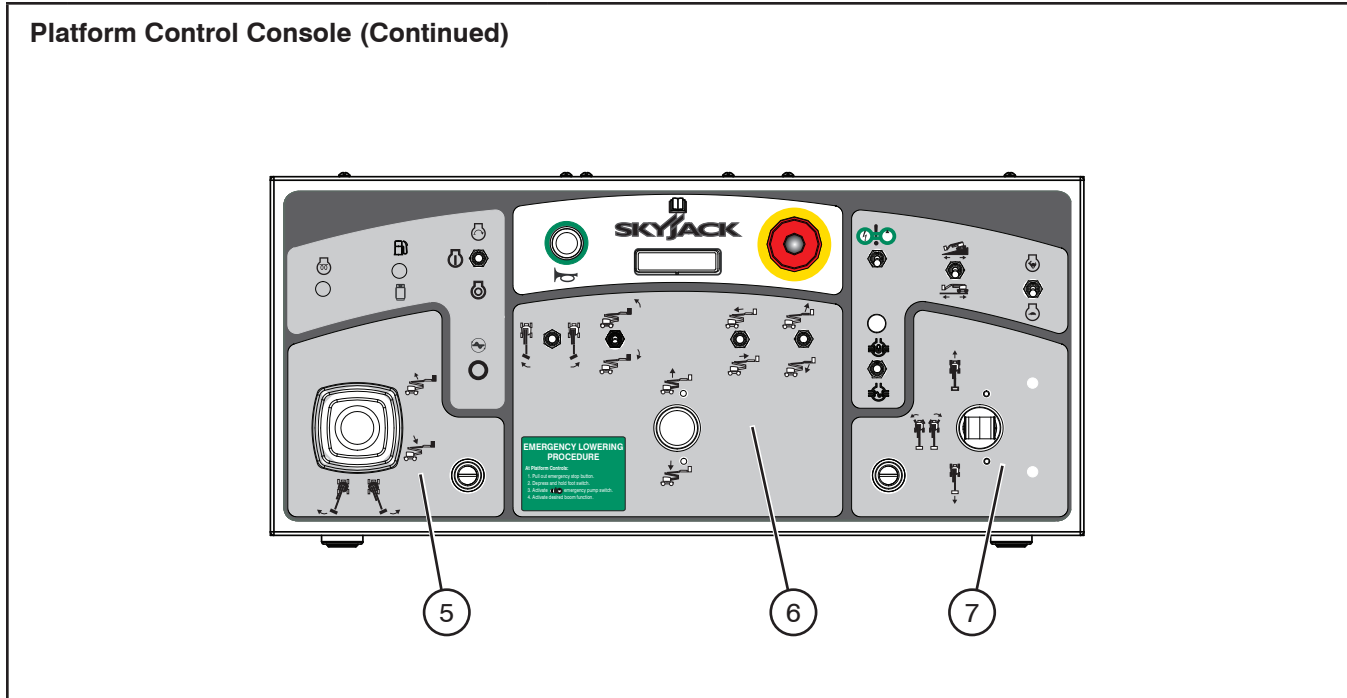

No.	Label Pictorial	Description
1		<p>Glow Plugs/Start Engine</p> <p>Select “” to energize glow plugs. Select “” for diesel fuel or “” for propane fuel. Push and hold “” to start engine and then return to “” on position or select “” to turn engine off. Select “” to turn hydraulic generator on or “” to turn it off.</p>
2		<p>Emergency Lowering Procedure</p> <p>Follow procedure outlined in label to lower the platform.</p>
3		<p>E-Stop/Horn</p> <p>Select “” to sound horn. Read operating manual “”. Push “” emergency stop to stop engine and disable controls.</p>
4		<p>Engine Controls/Emergency Power Unit</p> <p>Select “” to enable emergency power unit. Select “” low torque when driving on level ground or “” high torque when driving on a slope. Select either “” high or “” low engine throttle speed. Select “” to engage differential lock or “” to disengage differential lock.</p>

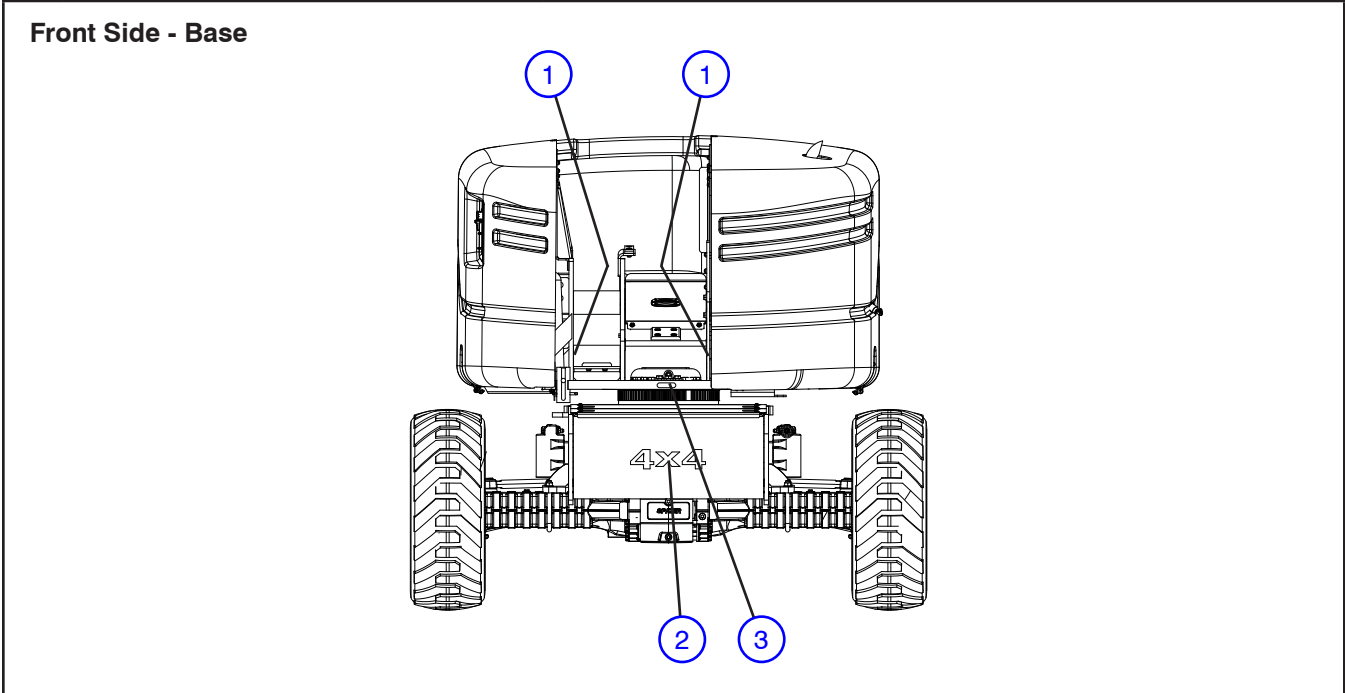

No.	Label Pictorial	Description
5		<p>Boom/Turret Controller</p> <p>Push and hold controller in this direction “” to rotate turret to the left or “” to rotate turret to the right.</p> <p>Push and hold the controller in this direction “” to raise main boom or “” to lower main boom.</p>
6		<p>Boom/Jib/Platform Controls</p> <p>Select “” to rotate platform to the left or “” to the right.</p> <p>Select “” to tilt platform up or “” down</p> <p>Select “” to extend fly boom or “” to retract fly boom.</p> <p>Select “” to move jib up or “” to move jib down.</p> <p>Select “” to raise riser or “” to lower riser.</p>
7		<p>Drive/Steer Controller</p> <p>Press rocker switch in this direction “” to steer left or “” to steer right.</p> <p>Push and hold controller in this direction “” to drive forward or “” to drive backward.</p>

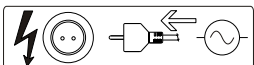

No.	Label Pictorial	Description
1		<p>Body Crushing Hazard Danger - Body crushing hazard</p>
2		<p>4x4 (If Equipped) Product identifier - 4 wheel drive</p>
3		<p>Connect AC Supply Connect AC supply here.</p>

California Proposition 65

Engine exhaust and some of its constituents are known to the State of California to cause cancer, birth defects, and other reproductive harm.

Battery posts, terminals, and related accessories contain lead and lead compounds, chemicals known to the State of California to cause cancer, birth defects, and other reproductive harm.

WASH HANDS AFTER HANDLING.

SKYJACK[™]

www.skyjack.com